

# LM-3000PRO EU

---

## INSTRUCTION MANUAL

### LETATWIN



- Ensure that you read this instruction manual prior to use.
- Ensure that you keep this instruction manual.
- Reproducing all or part of the contents of this document without permission is prohibited.
- The information in this document is subject to change without notice.
- Information including the latest models, consumables, optional items and manuals can be accessed through the URL and QR code shown here.  
<https://www.max-ltd.co.jp/int/letatwinfan-lm-3000pro/>



# TABLE OF CONTENTS

<b>Chapter 1 INTRODUCTION</b> .....	<b>5</b>
1-1 ESSENTIAL SAFETY PRECAUTIONS .....	6
1-2 PRECAUTIONS FOR USE .....	9
1-3 PRECAUTIONS FOR USE OF WIRELESS DEVICES .....	10
1-4 PC EDITOR COPYRIGHT .....	11
1-5 INSTRUCTION MANUAL TYPES AND AVAILABILITY .....	11
<b>Chapter 2 PRODUCT CAPABILITIES</b> .....	<b>12</b>
2-1 CONSUMABLES COMPATIBLE .....	13
2-1-1 CONSUMABLES COMPATIBLE WITH INSERTION CONNECTION .....	13
2-1-2 GUIDE TO CONSUMABLES BY APPLICATION .....	14
2-2 CONNECTION METHODS FOR PRINTING .....	15
2-3 MODELS COMPATIBLE WITH LETATWIN PC EDITOR PRO .....	15
<b>Chapter 3 BEFORE USE</b> .....	<b>16</b>
3-1 CONFIRMING PACKAGE CONTENTS .....	17
3-2 PART NAMES .....	18
3-3 CARRYING THE MACHINE .....	20
3-4 CONNECTING THE POWER CORD AND TURNING ON THE POWER .....	20
3-5 LANGUAGE SETTINGS .....	21
3-6 READING THE LCD DISPLAY (HOME SCREEN) .....	22
3-7 CONNECTING THE MAIN UNIT TO A COMPUTER .....	23
3-7-1 CONNECTING THE MAIN UNIT TO A COMPUTER .....	23
3-7-2 USB CONNECTION SETTINGS .....	24
3-7-3 SETTING UP A WIRED LAN CONNECTION .....	28
3-7-4 SETTING UP A WIRELESS LAN CONNECTION .....	35
3-8 DOWNLOADING AND INSTALLING LETATWIN PC EDITOR PRO .....	46
3-9 BLOCKS AND PITCH LENGTH/PITCH PRINT .....	47
3-10 PRINT AREA .....	48
3-11 AVAILABLE PITCH LENGTH SETTINGS .....	49
3-12 MAXIMUM PRINT LENGTH .....	49
<b>Chapter 4 OPERATING THE MAIN UNIT AND LOADING CONSUMABLES</b> .....	<b>50</b>
4-1 FULL CUTTING .....	51
4-2 ADJUSTING THE HALF CUTTING DEPTH .....	51
4-3 ADJUSTING THE PRINTING PRESSURE .....	52
4-4 LOADING GRIP SLEEVES .....	53
4-5 LOADING TUBES AND ID PLATES .....	55
4-5-1 SETTING THE TUBE HEATER IN POSITION .....	57
4-5-2 LOADING MAX GRIP TUBES, MAX TUBES AND GENERIC .....	59
4-5-3 MOUNTING ATTACHMENTS FOR USE WITH THIN TUBES AND THICK TUBES .....	60
4-6 CHANGING THE EXIT GUIDE .....	61
4-7 LOADING TAPE AND MARKER STRIPS .....	62
4-8 LOADING BLOCK MARKERS .....	66
4-9 INSTALLING THE INK RIBBON .....	69
4-10 INSTALLING THE REEL STAND .....	71
<b>Chapter 5 REPLACING CONSUMABLES</b> .....	<b>73</b>
5-1 REPLACING THE HALF CUTTER UNIT .....	74
5-2 REPLACING THE THERMAL HEAD .....	75

**Chapter 6 MAIN UNIT LCD DISPLAY CONTENT ..... 78**

- 6-1 HOME SCREEN ..... 79
- 6-2 PRINTING..... 80
- 6-3 FEEDING ..... 83
- 6-4 REMOVING USB MEMORY DEVICES ..... 83
- 6-5 SWITCHING THE HEATER ON AND OFF ..... 84
- 6-6 HELP ..... 84
- 6-7 SETTINGS ..... 85
- 6-8 MAIN UNIT SETTINGS ..... 86
  - 6-8-1 SLEEP TIMER..... 86
  - 6-8-2 TOUCH SOUND SETTINGS ..... 87
  - 6-8-3 ADJUSTING THE TOUCH PANEL ..... 87
  - 6-8-4 SETTING POWER INTERRUPTION PRINT RESTART MODE..... 88
  - 6-8-5 ADJUSTING SCREEN SETTINGS..... 88
- 6-9 PRINT SETTINGS..... 89
  - 6-9-1 SETTING THE PRINTING DENSITY ..... 90
  - 6-9-2 SETTING LOW TEMPERATURE MODE..... 90
  - 6-9-3 SETTING PRE-PRINT FEEDING ..... 91
  - 6-9-4 SETTING THE PRINTING LINE POSITION ..... 91
  - 6-9-5 SETTING THE CUTTING POSITION..... 92
  - 6-9-6 HORIZONTAL PRINTING LINE POSITION ..... 92
  - 6-9-7 POST-PRINT FEEDING ..... 93
  - 6-9-8 MARGINS BETWEEN PRINT FILES ..... 93
  - 6-9-9 ADJUSTING THE BLOCK MARKER SENSOR ..... 94
  - 6-9-10 SETTING THE HEATER TEMPERATURE..... 94
  - 6-9-11 SETTING THE HEAT RETENTION ..... 95
- 6-10 CONNECTION SETTINGS ..... 96
  - 6-10-1 INITIALIZING LAN SETTINGS ..... 96

**Chapter 7 BASIC PROCEDURE FROM TEXT INPUT TO PRINTING..... 97**

- 7-1 BASIC LETATWIN PC EDITOR PRO OPERATIONS ..... 98
  - 7-1-1 LAUNCHING LETATWIN PC EDITOR PRO ..... 99
  - 7-1-2 SELECTING THE MODEL..... 99
  - 7-1-3 SELECTING PRINT MATERIAL..... 100
  - 7-1-4 PRINT FORMAT ..... 101
  - 7-1-5 LETATWIN PC EDITOR PRO MAIN EDITOR SCREEN LAYOUT ..... 102
  - 7-1-6 ENTER DOCUMENTS ..... 103
  - 7-1-7 CHECKING PRINT DATA USING PREVIEWS ..... 104
  - 7-1-8 PRINTING..... 105

**Chapter 8 FUNCTIONS ..... 106**

- 8-1 CHANGING THE PRINT FORMAT ..... 108
  - 8-1-1 CHANGING THE NUMBER OF REPETITIONS..... 108
  - 8-1-2 180° ROTATION PRINTING SETTINGS (GRIP SLEEVES AND TUBES ONLY) ..... 109
  - 8-1-3 INVERTED PRINTING ..... 110
  - 8-1-4 UNDERLINING ..... 111
  - 8-1-5 FRAMES..... 112
  - 8-1-6 MAKING TABLES ..... 113
  - 8-1-7 CHANGING THE PITCH LENGTH ..... 118
  - 8-1-8 SORTING BY PITCH LENGTH..... 120
  - 8-1-9 AUTOMATICALLY CHANGING THE PITCH LENGTH BASED ON CHARACTER COUNT ..... 121
  - 8-1-10 AUTOMATIC CHARACTER SIZE ADJUSTMENT ..... 123
  - 8-1-11 FIXING CHARACTER SIZE ..... 125
  - 8-1-12 HALF CUTTING/LINE AND DOT PRINTING BETWEEN PITCHES..... 127
  - 8-1-13 VERTICAL AND HORIZONTAL TEXT SETTINGS ..... 129
  - 8-1-14 SETTING CHARACTER SPACING ..... 131

- 8-1-15 SETTING LINE SPACING ..... 133
- 8-1-16 CHANGING THE FONT ..... 135
- 8-2 ENHANCING CHARACTER RECOGNIZABILITY ..... 137**
  - 8-2-1 CHANGING PRINTING OF “6” AND “9” ..... 137
  - 8-2-2 ADDING SLASHES TO ZEROS (“0”) ..... 139
  - 8-2-3 BATCH ADDITION OF PERIODS AFTER TEXT ..... 141
  - 8-2-4 USING CLEAR FONT ..... 142
- 8-3 SETTING THE PRINT MODE AT LOW TEMPERATURES..... 143**
  - 8-3-1 USING THE TUBE HEATER..... 143
  - 8-3-2 LOWERING THE PRINT SPEED ..... 144
  - 8-3-3 ADJUSTING THE PRINTING DENSITY ..... 145
- 8-4 SETTING SEQUENCES..... 146**
  - 8-4-1 SETTING SEQUENCES ..... 146
  - 8-4-2 SETTING THE ORDER FOR PRINTING SEQUENCES ..... 149
- 8-5 ENTERING SYMBOLS AND TEXT WITH DIACRITICS..... 150**
  - 8-5-1 ENTERING ELECTRICAL INSTALLATION SYMBOLS ..... 150
  - 8-5-2 ENTERING SYMBOLS AND TEXT WITH DIACRITICS..... 153
- 8-6 CHECKING PREVIEWS..... 155**
  - 8-6-1 VIEWING INDIVIDUAL PREVIEWS ..... 155
  - 8-6-2 FULL PREVIEW ..... 156
- 8-7 BATCH EDITING OF SETTING VALUES (CHARACTER SIZE, CHARACTER WIDTH, REPEAT, PITCH LENGTH, UNDERLINE, INVERT, 180° ROTATION PRINT)..... 157**
  - 8-7-1 BATCH CHANGES FROM THE EDIT MENU..... 157
  - 8-7-2 DOUBLE CLICKING TO BATCH CHANGE ITEMS IN LETATWIN PC EDITOR PRO ..... 159
- 8-8 ADVANCED PRINT SETTINGS ..... 160**
  - 8-8-1 SELECTING THE MODEL TO PRINT ..... 160
  - 8-8-2 SELECTING THE PRINT RANGE..... 161
  - 8-8-3 SELECTING THE NUMBER OF PRINT COPIES..... 163
  - 8-8-4 PRINT ALIGNMENT..... 164
  - 8-8-5 SEPRATING MAIN PRINTER UNIT AND LETATWIN PC EDITOR PRO SETTINGS AND PRINTING FROM LETATWIN PC EDITOR PRO ..... 165
  - 8-8-6 SETTING THE CUTTING POSITION..... 167
  - 8-8-7 SETTING THE PRINTING LINE POSITION ..... 168
  - 8-8-8 SETTING POST-PRINT FEEDING ..... 169
  - 8-8-9 PRE-PRINT FEEDING..... 171
  - 8-8-10 SETTING MARGINS BETWEEN PRINT FILES..... 172
  - 8-8-11 ADJUSTING THE HORIZONTAL PRINTING LINE POSITION (BLOCK MARKERS ONLY)..... 173
  - 8-8-12 SWITCHING DISPLAYED UNITS BETWEEN MILIMETERS AND INCHES ..... 174
- 8-9 REGISTERING DEFAULT SETTINGS (INITIAL VALUES) ..... 175**
  - 8-9-1 REGISTERING BASIC SETTINGS..... 176
  - 8-9-2 REGISTERING PRINT SETTINGS ..... 176
  - 8-9-3 REGISTERING PRINT PARAMETER SETTINGS ..... 177
- 8-10 SAVING AND SENDING FILES ..... 179**
  - 8-10-1 SAVING FILES WITH A NEW NAME ..... 179
  - 8-10-2 SAVING FILES BY OVERWRITING ..... 181
  - 8-10-3 SENDING FILES ..... 182
  - 8-10-4 RECORDING COMMENTS IN FILES ..... 183
- 8-11 DOUBLE-SIDED PRINTING ..... 185**
- Chapter 9 USING LETATWIN PC EDITOR PRO DATA..... 189**
  - 9-1 USING LETATWIN PC EDITOR PRO DATA ..... 190
  - 9-2 IMPORTING DATA CREATED USING SPREADSHEET SOFTWARE INTO LETATWIN PC EDITOR PRO..... 191

9-3 IMPORTING CSV FILES..... 192

    9-3-1 IMPORTING PRINTING CONTENT ONLY..... 193

    9-3-2 COPYING AND PASTING FROM CSV FILES..... 194

    9-3-3 IMPORTING PRINTING CONTENT AND REPETITION AND PITCH LENGTH DATA..... 195

    9-3-4 IMPORTING BY DRAGGING CSV FILES ONTO THE LETATWIN PC EDITOR PRO ICON..... 197

**Chapter 10 MAINTENANCE ..... 198**

    10-1 PLATEN ROLLER CLEANING..... 199

    10-2 THERMAL HEAD CLEANING..... 200

    10-3 PRINT MATERIAL SENSOR CLEANING..... 201

    10-4 CLEANING THE BLOCK MARKER SENSOR AND BLOCK MARKER ATTACHMENT .... 202

    10-5 CLEANING MEDIA GUIDES B AND D  
        (METHOD FOR REMOVING TAPE ADHESIVE)..... 203

**Chapter 11 TROUBLESHOOTING ..... 204**

    11-1 TROUBLESHOOTING ..... 205

**Chapter 12 APPENDICES ..... 208**

    12-1 LETATWIN PC EDITOR PRO DISPLAY CREATION DETAILS ..... 209

    12-2 LIST OF PRINT MATERIAL AND OPTIONAL ITEMS ..... 212

    12-3 LIST OF DEFAULT VALUES..... 215

    12-4 PRODUCT SPECIFICATIONS ..... 216

    12-5 MAIN UNIT AND LETATWIN PC EDITOR PRO VERSION INFORMATION..... 219

        12-5-1 MAIN UNIT VERSION INFORMATION..... 219

        12-5-2 LETATWIN PC EDITOR PRO VERSION INFORMATION..... 219

        12-5-3 HOW TO UPDATE THE MAIN UNIT ..... 220

    12-6 CONTACT INFORMATION..... 221

# Chapter 1

## INTRODUCTION

---



1-1 ESSENTIAL SAFETY PRECAUTIONS.....	6
1-2 PRECAUTIONS FOR USE.....	9
1-3 PRECAUTIONS FOR USE OF WIRELESS DEVICES .....	10
1-4 PC EDITOR COPYRIGHT.....	11
1-5 INSTRUCTION MANUAL TYPES AND AVAILABILITY .....	11

# 1-1 ESSENTIAL SAFETY PRECAUTIONS



Make sure to carefully read the “Essential Safety Precautions” before using this machine and ensure correct use.

All of the items shown here cover important safety information. Always use this machine in accordance with the information in this document.

## ■ Indications

 <b>WARNING</b>	Failure to act in accordance with this information could lead to the death or serious injury of an operator.
 <b>CAUTION</b>	Failure to act in accordance with this information could lead to the injury of an operator, damage to property or the loss of created data.

## ■ Symbols

 Denotes information to pay attention to. Indications in or near this symbol denote specific <b>warnings</b> .	 Denotes prohibited actions. Indications in or near this symbol denote specific <b>prohibitions</b> .	 Denotes actions that must be performed. Indications in or near this symbol denote specific <b>instructions</b> .
---	--	--

### NOTE

Denotes actions that must not be performed, including operations that may lead to the machine malfunctioning or requiring repair and actions that require resetting or similar actions to return the machine to its original state.









### MEMO

Denotes key points during operation and tips to enhance convenience.







Indicates references to explanations on other pages.

## **WARNING**

 	<ul style="list-style-type: none"> <li>• <b>Always earth this machine.</b> Electrical leaks can cause fire or electric shock.</li> <li>• Always earth before inserting the power plug into an electric outlet. Always disconnect the power plug from the electric outlet before disconnecting from earth.</li> </ul>
	<ul style="list-style-type: none"> <li>• <b>Always use 100-240V electric outlets</b> Using power supplies other than 100-240V can cause malfunction, fire or electric shock.</li> <li>• <b>Clean the power plug periodically</b> Dust may accumulate over time, leading to fire or malfunction.</li> </ul>
	<ul style="list-style-type: none"> <li>• <b>Do not insert fingers, pens, needles, or any other foreign object inside the machine</b> Doing so can cause malfunction, fire, electric shock or injury.</li> <li>• <b>Only use the power cord included with this machine</b> Using other power cords can cause fire or electric shock.</li> <li>• <b>Obtain power directly from an electrical outlet, do not place excessive load on one electric outlet</b> Doing so may cause fire.</li> <li>• <b>Do not modify the power cord</b> Modifying the power cord may cause fire or electric shock.</li> <li>• <b>Never place heavy objects on the power cord</b> Doing so can damage the cord, leading to fire or electric shock.</li> <li>• <b>Do not use while the power cord is bundled</b> Heat may cause fire or malfunction. Always unwind before use.</li> <li>• <b>Do not use power cords and cables that are damaged</b> Doing so may cause malfunction, fire or electric shock.</li> <li>• <b>Do not insert or disconnect the power plug with wet hands</b> Doing so may cause electric shock.</li> <li>• <b>Do not use the machine with wet hands or while wearing wet clothes</b> Doing so may cause electric shock.</li> <li>• <b>Do not place paper or fabric on top of the machine while it is connected to an electric outlet</b> Doing so can cause fire or malfunction.</li> <li>• <b>When unplugging the power plug, always hold onto the plug and do not pull on the power cord</b> Pulling on the cord can damage it and cause fire or electric shock.</li> </ul>
 	<ul style="list-style-type: none"> <li>• <b>Do not splash water or chemicals over the machine</b> In the event that liquid enters the machine, disconnect the power plug from the electric outlet immediately and contact a dealer to request repair. Continuing to use the machine may cause malfunction, fire or electric shock.</li> <li>• <b>Do not continue to use a damaged or malfunctioning machine</b> If the machine is emitting smoke, producing abnormal sounds or odors, or otherwise malfunctioning, continuing use may cause fire or electric shock. Immediately disconnect the power plug from the electric outlet and contact a dealer to request repair.</li> </ul>
	<ul style="list-style-type: none"> <li>• <b>Never disassemble the machine</b> Doing so can cause fire, electric shock or malfunction.</li> </ul>
	<ul style="list-style-type: none"> <li>• <b>Keep main unit at least 20cm away from people while in operation</b> There is a risk of exposure to electromagnetic waves.</li> </ul>

## CAUTION

	<ul style="list-style-type: none"> <li>• <b>Always place the machine in a horizontal surface</b> Placing the machine in unstable locations, such as unsteady tables or inclined surfaces, may cause the machine to fall and result in injury or malfunction.</li> <li>• <b>Do not use the machine while it is exposed to direct sunlight, in hot or humid locations, or while condensation is present</b> Doing so may cause unstable operation or malfunction.</li> <li>• <b>Do not use in the same electric outlet as other equipment that requires significant load (air conditioning units, refrigerators, microwave ovens, OA devices, etc.)</b> Doing so may cause the voltage to drop and result in the machine not operating correctly.</li> <li>• <b>Do not touch the USB, LAN and power connectors directly</b> Doing so may cause damage due to static electricity.</li> </ul>
	<ul style="list-style-type: none"> <li>• <b>Never touch the thermal head</b> The thermal head is hot immediately after printing and may cause burns. In addition, dirt from hands can cause the thermal head to malfunction.</li> <li>• <b>Never touch the full cutting blade or the half cutting blade</b> Doing so can cause injury.</li> <li>• <b>Never touch the tube heater inlet and outlet</b> Doing so can cause burns.</li> <li>• <b>Never touch the print material outlet</b> Doing so can cause injury.</li> <li>• <b>Never insert hands directly under the half cutting blade position inside the consumables inlet</b> Doing so can cause injury.</li> </ul>
	<ul style="list-style-type: none"> <li>• <b>Content saved to computers and USB memory devices cannot be saved indefinitely</b> <u>Please note that MAX is not responsible for damages or lost profits resulting from data loss attributable to causes such as malfunctions and repairs.</u></li> <li>• <b>This product includes an app, use it in networks or facilities that are subject to appropriate security management</b></li> <li>• <b>Do not enter unnecessary personal information or security-related information into file data or settings data</b></li> <li>• <b>Ensure appropriate management of USB memory devices and other storage media used with this equipment to prevent loss and ensure that proper safety measures are taken before disposal</b></li> </ul>
	<ul style="list-style-type: none"> <li>• <b>When the machine will not be used for a long time, for safety reasons, always disconnect the power plug from the electric outlet</b></li> <li>• <b>Always disconnect the power plug from the electric outlet when changing the installation location</b> Moving the machine with the power plug inserted into an electric outlet may damage the plug or cord and cause fire or electric shock.</li> </ul>
	<ul style="list-style-type: none"> <li>• <b>If items such as print material or foreign objects become trapped and prevent the printer or cutters (half cutter and full cutter) operating correctly, always turn off the power by turning off the lock switch on the rear of the machine or disconnecting the plug before removing the obstruction</b> If the power is on, the machine may operate unexpectedly and cause injury.</li> <li>• <b>When replacing the half cutting blade, always turn off the power by turning off the lock switch on the rear of the machine or disconnecting the plug</b> If the power is on, the machine may operate unexpectedly and cause injury.</li> <li>• <b>Always turn the power off before inserting a USB memory device. When removing a USB memory device, always turn the power off first, or press the USB removal key on the LCD display, then wait for the USB removal button light to turn off before performing removal.</b> Inserting or removing USB memory devices with the power on or while the USB icon is illuminated may cause data loss or corruption.</li> </ul>

# 1-2 PRECAUTIONS FOR USE

To prevent malfunctions and other issues related to this machine, follow the precautions below.

- This machine is a precision product. Handle with care to avoid dropping or causing impacts to the machine.
- Print material with significant bends, crushing and dirt cannot be used for printing. In particular, hard dirt or foreign material on print material can damage the thermal head.
- Do not block or insert objects into the print material outlet.  
Do not pull on the print material during printing.
- Do not pull out the power cable while the main unit power is on or immediately after the power has been turned off. Doing so may cause malfunction or damage such as loss of settings and memory content. Wait for the LCD screen display to turn off before disconnecting the power cord.
- Do not press on the LCD screen with excessive force. Doing so can break the screen.
- To clean dirt from the machine, wipe with a soft, dry cloth. Do not use organic solvents or chemicals, including thinner, benzene or alcohol. Such substances can cause deformation or discoloration of the machine.
- Condensation may form inside the main unit in situations such as when the machine is moved from a cold exterior location to a heated indoor location. In such cases, leave the machine in the room for at least 30 minutes and check that the condensation is no longer present before use.
- Do not use or store the machine in the following locations. Doing so can cause issues with the machine.
  - (1) Locations exposed to direct sunlight or near a heater or other heat source
  - (2) Locations with significant dust or humidity
  - (3) Locations subject to vibrations or impacts
  - (4) Do not use in locations where the main unit temperature may reach 5°C and lower or 35°C and higher
    - Leaving the device in a high temperature environment (35°C or higher) can cause the LCD screen to turn black and make the text difficult to read.  
Use the machine within the specified temperature range.
    - Leaving the device in a low temperature environment (5°C or lower) can cause the LCD screen display to fade and make the text difficult to read.  
Use the machine within the specified temperature range.
  - (5) Do not store in locations where the temperature may reach 0°C and lower or 40°C and higher
- For optimal ease of use, using official MAX consumables is recommended.
- Use the device in an environment where access is restricted to authorized personnel only.
- When disposing of the product, initialize the wireless settings. If you dispose of the product without initializing it, the wireless settings may become known.
- Please note that if you lose the USB memory, the files stored on the memory may become known.

## ■ Notes when connecting to wireless LAN

### Effects on other devices

Radio waves produced by this machine may impact the operation of electronic medical devices and other equipment.

Due to the risk of accidents occurring in some cases, turn off the power of this machine and wireless communication devices in the following locations.

- In hospitals/on trains/on board aircraft/at gas stations and other locations where flammable gas may be present
- Near automatic doors and fire alarms

### CAUTION

As security measures when communicating using wireless LAN technology, this device supports security functions in line with wireless LAN standards. However, depending on factors such as the content of settings, security may not always be sufficient. Exercise due caution when using Wireless LAN communication. Please note that MAX is not responsible for any information leaks that occur when using wireless LAN technology.

In the event of an unforeseen issue, data saved in tablets, smartphones or other external devices connected to this product may be corrupted or lost.

To guard against such occurrences, always create a backup in advance. In addition, please note that MAX is not responsible for corruption or loss of data, or for damage to connected devices, regardless of the circumstances.

- When using wirelessly, you can choose not to encrypt, but there is a risk that the contents of files communicated between the PC and the device may be intercepted.

### Radio frequency information

This machine operates in the 2.4GHz band and may use the same radio frequencies as other wireless devices. To avoid radio interference with other wireless devices, observe the precautions below during use.

### Precautions when using this machine

This machine operates in the 2.4GHz frequency band. In addition to microwave ovens and other industrial, scientific and medical devices, equipment that operates in this frequency band includes other similar radio stations, premises radio stations requiring licenses used for mobile object identification in settings such as factory production lines, low-power radio stations not requiring licenses, and amateur radio stations (hereinafter, this equipment is summarized as “other radio stations.”)

1. Before using this machine, check whether any other radio stations are being operated nearby.
2. In the event that radio interference occurs between this machine and other radio stations, take prompt action to move the device to another location to continue use or discontinue use of this device (stop the emission of radio waves).
3. In the event of any doubts or other issues, contact MAX customer support for assistance. Information regarding MAX customer support is included at the end of this Owner's Manual. This wireless device operates in the 2.4GHz band. OFDM and DSSS have been adopted as the modulation methods, and the interference is 40m.

### WARNING



- **Turn this machine off when on board aircraft**

This machine is equipped with wireless functions. Radio waves emitted by this device may impair the operation of aircraft.

- **Do not use this machine near medical equipment**

Radio waves produced by this machine may impact electrical medical devices.

- **Use of this machine in other countries may be subject to criminal penalties.**

# 1-4 PC EDITOR COPYRIGHT

## ■ Precautions: Using this Instruction Manual and LETATWIN PC EDITOR PRO

- The copyright of this software belongs to MAX CO., LTD. in Japan.
- You may not use or copy part or all of this software or Instruction Manual without permission.
- This software and Instruction Manual can only be used under the license agreement of this product.
- Contents saved on a computer cannot be saved indefinitely. Please note that MAX is not responsible for damages or lost profits resulting from data loss attributable to causes such as malfunctions and repairs.
- Software specifications and manual contents are subject to change without notice.
- Any group names and personal names displayed in the samples of this Instruction Manual are fictitious and have no relation to existing groups or individuals.

# 1-5 INSTRUCTION MANUAL TYPES AND AVAILABILITY

This machine has three types of manuals. Ensure that you read them before use.

## (1) Instruction Manual (print and digital versions)

Provides a comprehensive description of the product, including how to use the product, precautions for use, how to install software and print drivers, and error messages and appropriate countermeasures.

Access methods

The manual can be accessed using the two methods described below.

- 1 View on the MAX website  
URL: <https://www.max-ltd.co.jp/int/letatwinfan-lm-3000pro/>



- 2 Viewing on LETATWIN PC EDITOR PRO.  
Open LETATWIN PC EDITOR PRO, then click on “Instruction Manual” under Help on the main editing screen.

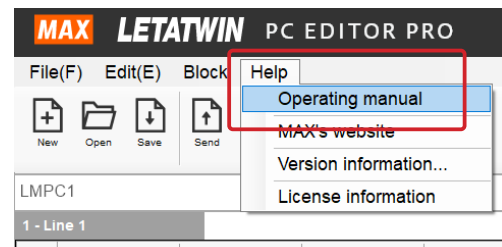

## (2) Quick Reference (included with product)

Explains how to set consumables in position.

## (3) Safety Guidance (included with product)

Explains safety precautions.

- The utmost care has been taken to ensure the accuracy of these documents. In the event that you encounter any potential omissions or inaccuracies, please contact us.
- Please note that MAX is not liable for any damages, loss of profits, or claims from third parties resulting from use of this machine or printed items created using this machine or from the disappearance or alteration of data due to factors such as malfunctions or repairs.

# Chapter 2

## PRODUCT CAPABILITIES

---

<b>2-1 CONSUMABLES COMPATIBLE.....</b>	<b>13</b>
2-1-1 CONSUMABLES COMPATIBLE WITH INSERTION CONNECTION.....	13
2-1-2 GUIDE TO CONSUMABLES BY APPLICATION.....	14
<b>2-2 CONNECTION METHODS FOR PRINTING.....</b>	<b>15</b>
<b>2-3 MODELS COMPATIBLE WITH LETATWIN PC EDITOR PRO.....</b>	<b>15</b>

# 2-1 CONSUMABLES COMPATIBLE

The LM-3000PRO can print on the following materials.

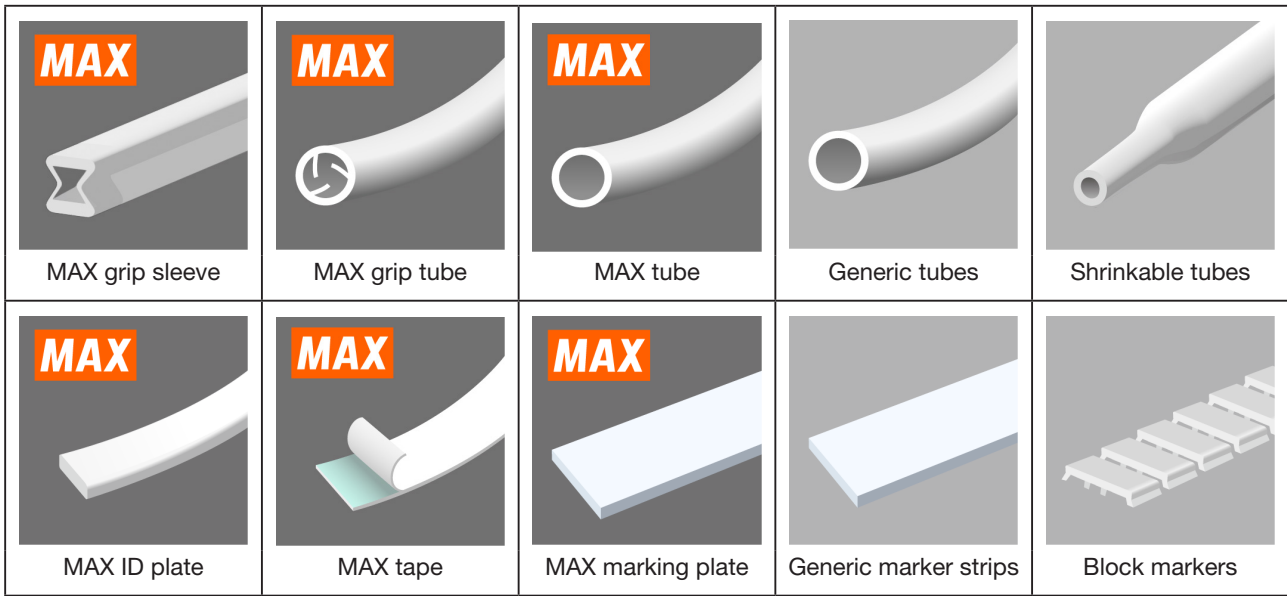

## 2-1-1 CONSUMABLES COMPATIBLE WITH INSERTION CONNECTION

### ■ MAX grip sleeve

- Flat printing surface, easy to read.
- Fits close to wires, does not rotate.
- Not fixed in place, but resistant to slipping.
- Moves smoothly, enabling position adjustment.
- Pitch length can be changed depending on the number of characters.

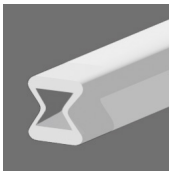

### ■ MAX grip tube

- Not fixed in place, but resistant to slipping.
- Moves smoothly, enabling position adjustment.
- Neatly aligned, making indications easy to see.
- Pitch length can be changed depending on the number of characters.







**We do not guarantee proper printing and operation with non-MAX genuine consumables.**

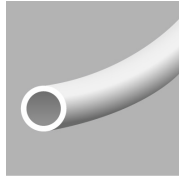

Please perform an operation check in advance before use.

## 2-1-2 GUIDE TO CONSUMABLES BY APPLICATION

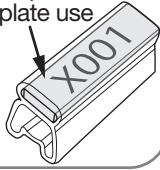
### 1. Labeling electrical cables

 <p>MAX grip sleeve</p>	 <p>MAX grip tube</p>	 <p>MAX tube</p>	 <p>Generic tubes</p>
 <p>Shrinkable tubes</p>	 <p>MAX ID plate</p> <div data-bbox="810 544 1026 745" style="border: 1px solid black; padding: 5px; display: inline-block;"> <p>Example of ID plate use</p>  </div>		

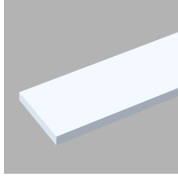
### 2. Labeling terminal blocks

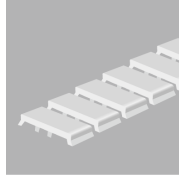
 <p>MAX marking plate</p>	 <p>Generic marker strips</p>	 <p>MAX tape</p>	 <p>Block markers</p>
---	---	---	---

### 3. Labeling devices, etc.

 <p>MAX tape</p>
---

## 2-2 CONNECTION METHODS FOR PRINTING

Install LETATWIN PC EDITOR PRO on your computer before use.

→ 3-8 DOWNLOADING AND INSTALLING LETATWIN PC EDITOR PRO Supported OS: Windows11 (as of March 2026)

### Printing from a computer

#### 1. Connecting with USB cable

Connect the main unit to a computer using a USB cable.

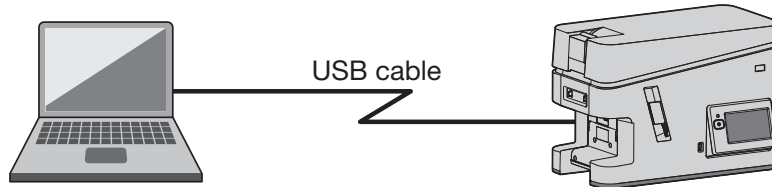

#### 2. Connecting with wired LAN

Use the wired LAN connection section to connect a computer to the port on the main unit through a LAN cable.

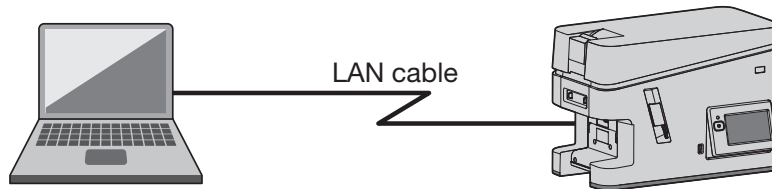

#### 3. Connecting with wireless LAN

Connect the main unit and computer over Wi-Fi.

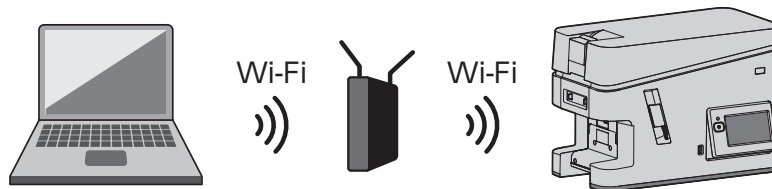

### Printing from main unit

Printing can be performed using the main unit alone. To do so, insert a USB memory device pre-loaded with the print data into the main unit.

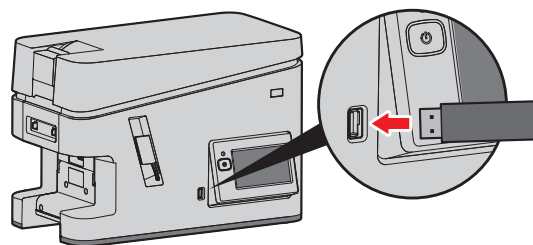

## 2-3 MODELS COMPATIBLE WITH LETATWIN PC EDITOR PRO

LETATWIN PC EDITOR PRO also supports the following models.

• LM-550A3 • LM-550A2 • LM-550A

# Chapter 3







## BEFORE USE

---

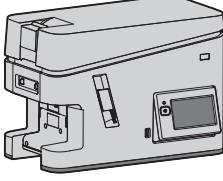
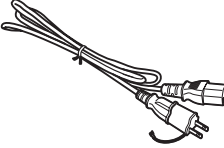
3-1 CONFIRMING PACKAGE CONTENTS.....	17
3-2 PART NAMES .....	18
3-3 CARRYING THE MACHINE.....	20
3-4 CONNECTING THE POWER CORD AND TURNING ON THE POWER....	20
3-5 LANGUAGE SETTINGS.....	21
3-6 READING THE LCD DISPLAY (HOME SCREEN).....	22
3-7 CONNECTING THE MAIN UNIT TO A COMPUTER .....	23
3-7-1 CONNECTING THE MAIN UNIT TO A COMPUTER.....	23
3-7-2 USB CONNECTION SETTINGS .....	24
3-7-3 SETTING UP A WIRED LAN CONNECTION .....	28
3-7-4 SETTING UP A WIRELESS LAN CONNECTION .....	35
3-8 DOWNLOADING AND INSTALLING LETATWIN PC EDITOR PRO .....	46
3-9 BLOCKS AND PITCH LENGTH/PITCH PRINT .....	47
3-10 PRINT AREA.....	48
3-11 AVAILABLE PITCH LENGTH SETTINGS .....	49
3-12 MAXIMUM PRINT LENGTH .....	49

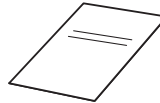
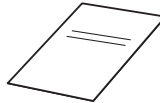
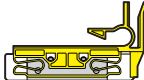
# 3-1 CONFIRMING PACKAGE CONTENTS

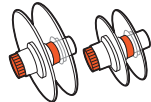
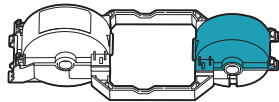
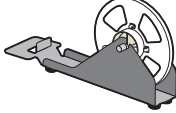
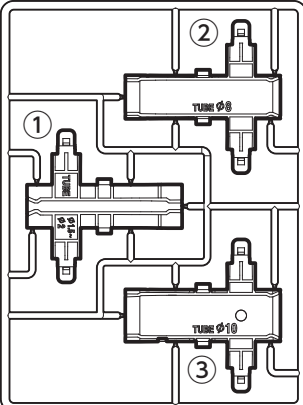
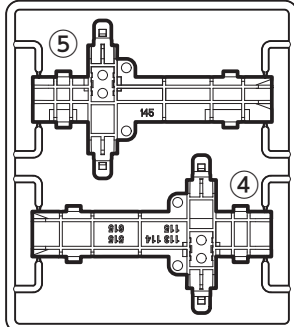
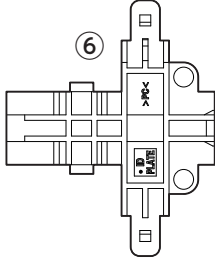
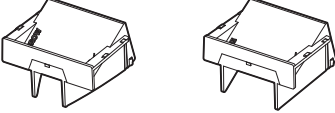
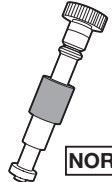
Check that all of the items below have been included with your product.

 <p>Main unit</p>	 <p>Power cord</p>	 <p>Quick Reference Manual</p>	 <p>Software use license</p>	 <p>Safety guide</p>
 <p>Half cutter unit *Set in main unit.</p>	 <p>Ink ribbon (LM-IR3015B)</p>	 <p>Ribbon flange</p>	 <p>Ink ribbon cassette</p>	 <p>Reel stand</p>
 <p>① <math>\phi</math>1.5 to <math>\phi</math>2.0 tube attachment ② <math>\phi</math>8 tube attachment ③ <math>\phi</math>10 tube attachment</p>	 <p>④ Block marker attachment For 2009-113/114/115/515/615 ⑤ Block marker attachment for 2009-145</p>	 <p>⑥ ID plate attachment</p>		
 <p><b>NARROW</b> (Narrow) *Set in main unit.</p> <p><b>WIDE</b> (Wide)</p>	 <p>(1) For LM-SL34 (2) For LM-SL37 (3) NORMAL</p> <p><b>NORMAL</b></p>			
<p>Exit guides (2 types)</p>	<p>Platen rollers (4 types) *Stored in platen roller storage case. <b>NORMAL</b> is set in main unit.</p>	<p>Platen roller storage case</p>		

Please purchase a USB-A to USB-B type cable (certified to meet USB standards).

# 3-2 PART NAMES

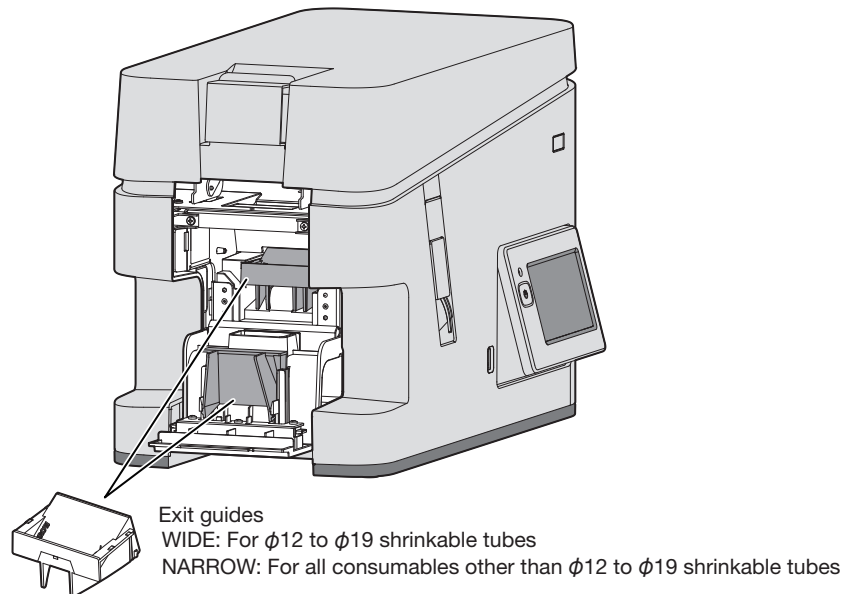
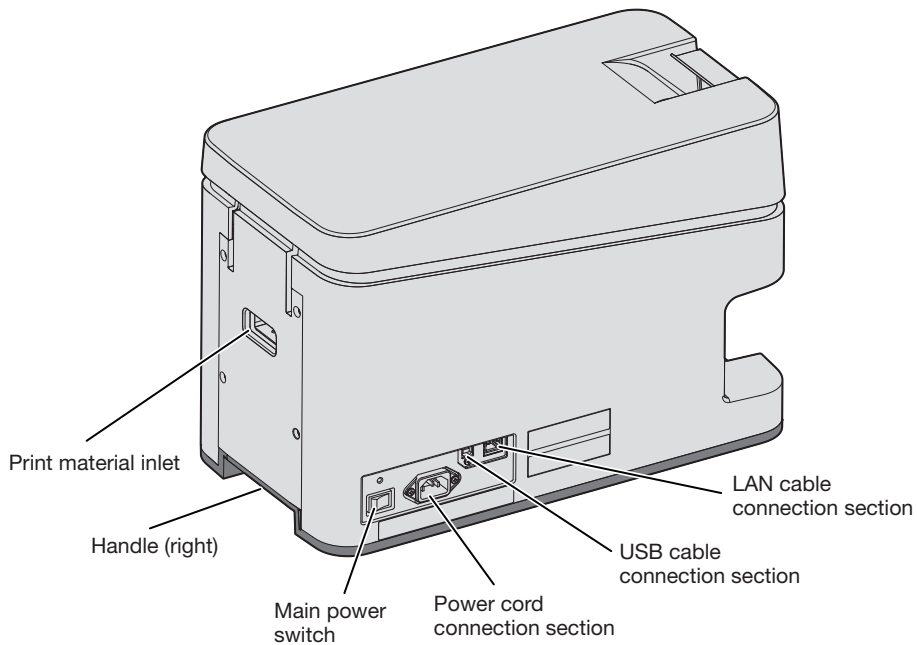
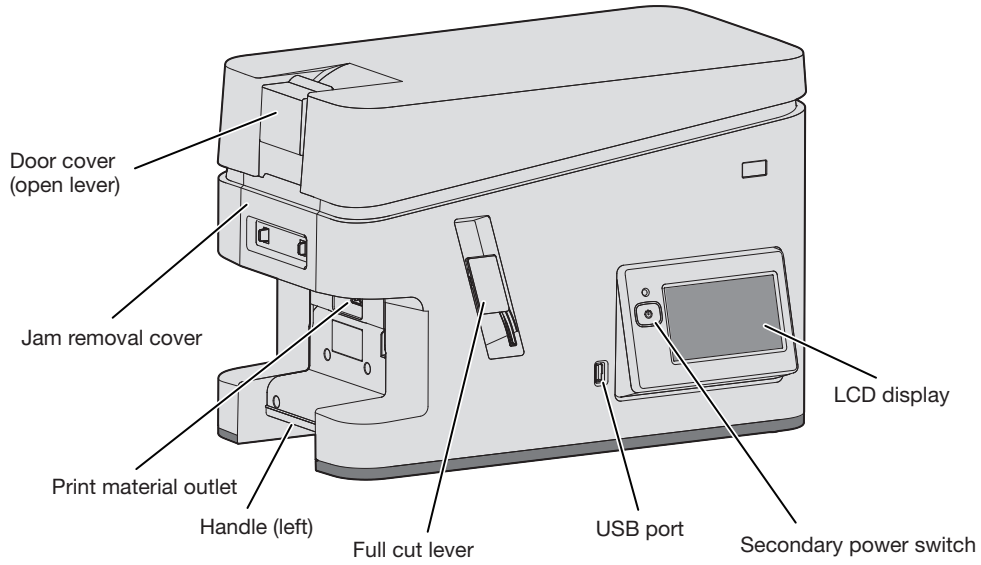

## Interior

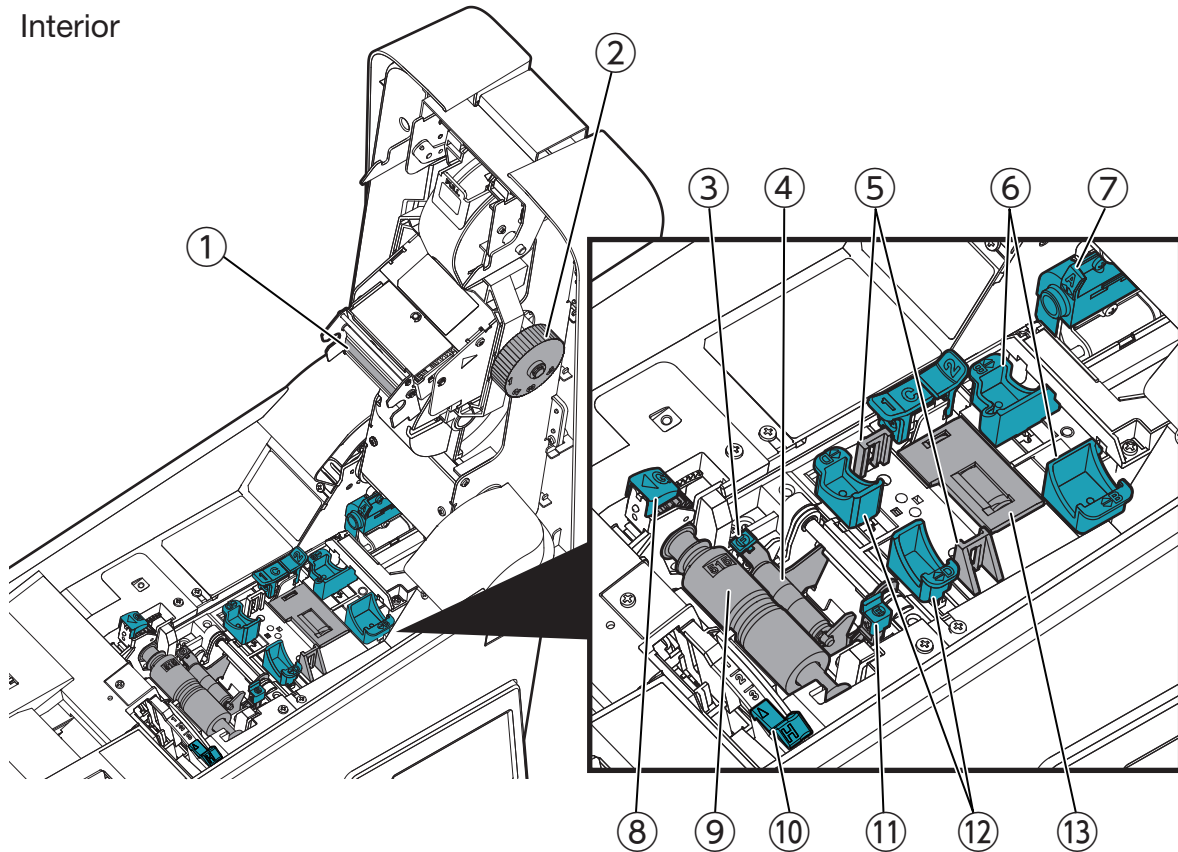

①	Thermal head
②	Printing pressure adjustment dial
③	M roller set lever
④	M roller
⑤	Attachment guide
⑥	Media guide B
⑦	Tube heater
⑧	Platen roller set lever
⑨	Platen roller
⑩	Half cutting depth adjusting lever
⑪	M roller release lever
⑫	Media guide D
⑬	Length Measurement Sensor(encoder)

## 3-3 CARRYING THE MACHINE

The machine has two handles, one at each end. Lift by the handles when carrying the machine.

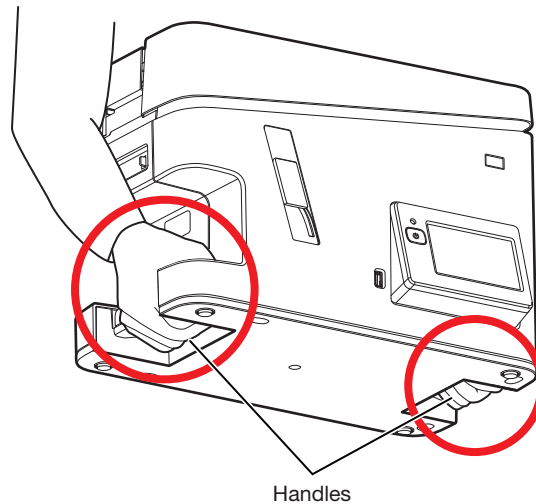

## 3-4 CONNECTING THE POWER CORD AND TURNING ON THE POWER

- 1 Securely insert the power cord into the power cord connection section on the rear on the main unit.

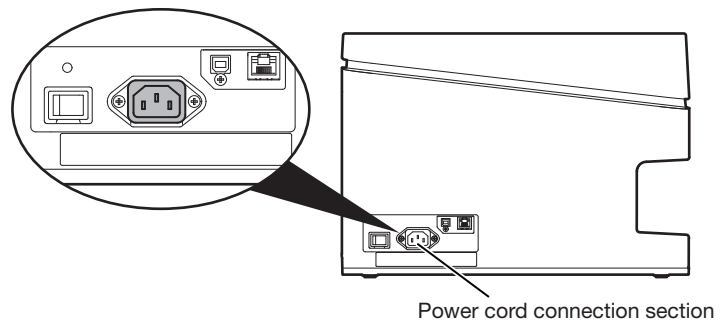

- 2 Insert the power cord into the electric outlet.

 <b>WARNING</b>	
	<ul style="list-style-type: none"><li>• <b>Always earth this machine</b> Always earth this machine before inserting the power plug into an electric outlet. Always disconnect the power plug from the electric outlet before disconnecting from earth.</li></ul>

- 3 Connect a computer to the main unit using a USB cable or LAN cable.  
→ 3-7 CONNECTING THE MAIN UNIT TO A COMPUTER

- 4 Press the main power switch (lock switch) on the main unit.  
Next, press the secondary power button next to the LCD display. The LCD display lights up.

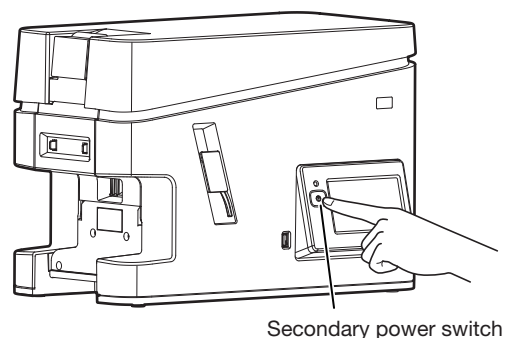
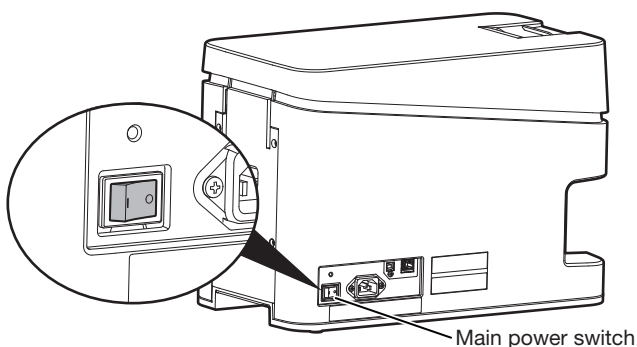

# 3-5 LANGUAGE SETTINGS

1 On the main unit's home screen, press the  icon.

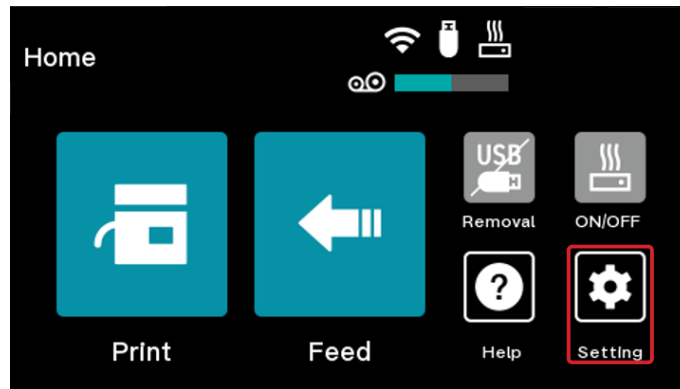

2 Press the  icon.

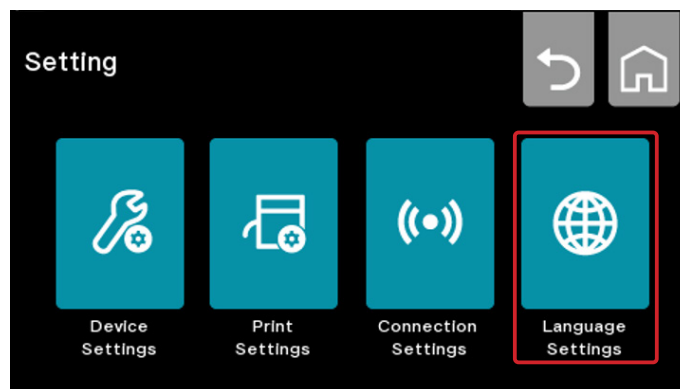

3 Select a language, then press "OK."

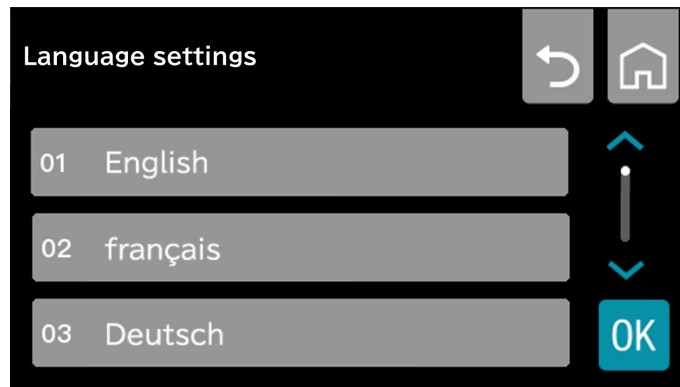

\* Based on the main unit language settings, the LCD screen displays languages using DynaFont (English, German, French, Italian, Spanish, Russian, Polish, Turkish, Korean, Vietnamese). DynaFont is a registered trademark of DynaComware Taiwan Inc.

**Simplified Chinese, Traditional Chinese : Copyright©BEIJING FOUNDER ELECTRONICS CO.. LTD**

The language settings for "LETATWIN PC EDITOR PRO" can be configured under File - Language.

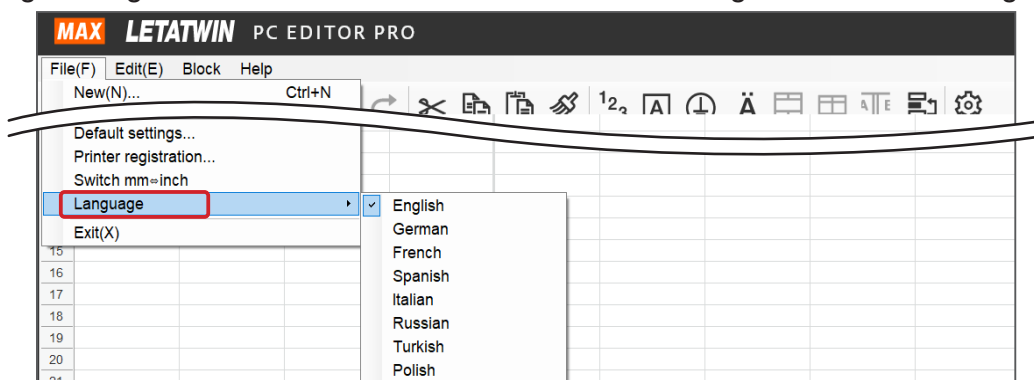

## 3-6 READING THE LCD DISPLAY (HOME SCREEN)

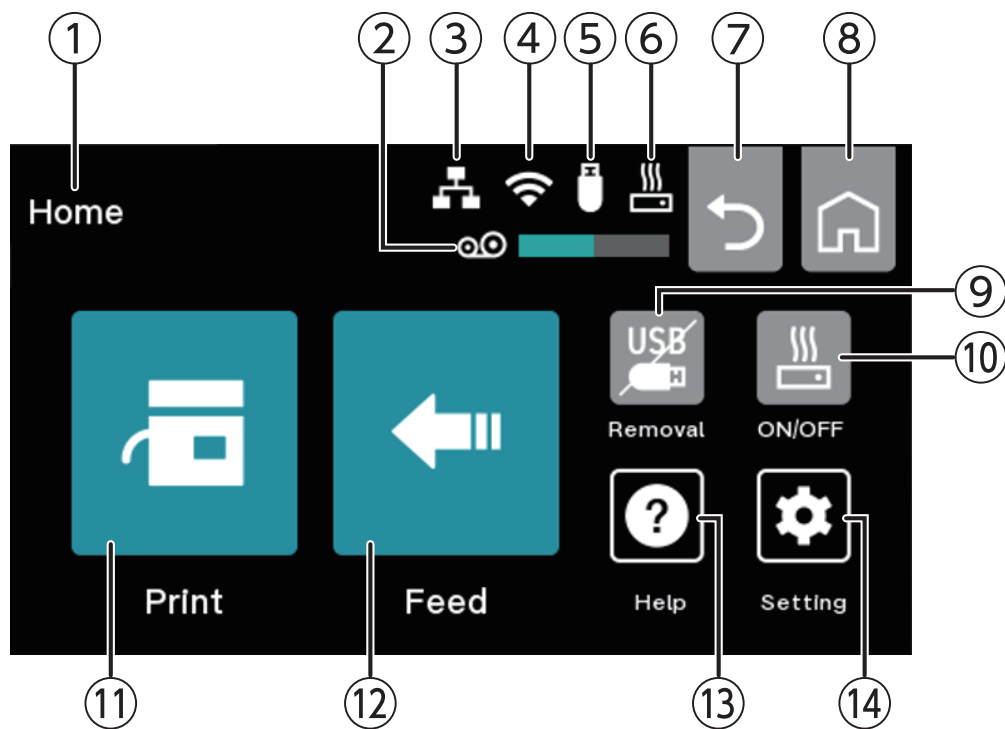

①	—	Screen title
②		Displays the remaining amount of ink ribbon.
③		Lights when connected to a wired LAN connection.
④		Lights when connected to a wireless LAN connection.
⑤		Lights when a USB memory device is inserted.
⑥		Lights when the heater is on.
⑦		Returns to the previous screen.
⑧		Returns to the home screen.
⑨		When the USB memory device is removed, the electrical flow to the USB memory is stopped.
⑩		Switches the heater on and off.
⑪		Performs printing.
⑫		Feeds the material to a position where the cutter (half cutter or full cutter) can cut it.
⑬		Displays the help menu. <a href="#">→ 6-6 HELP</a>
⑭		Used to adjust the main unit settings, print settings, connection settings and language settings.

# 3-7 CONNECTING THE MAIN UNIT TO A COMPUTER

## 3-7-1 CONNECTING THE MAIN UNIT TO A COMPUTER

A computer can be connected to the main unit using the three methods shown below.

1. USB connection
2. Wired LAN connection
3. Wireless LAN connection

The settings required for each type of connection are as shown below.

	LETATWIN PC EDITOR PRO setting	Main printer unit settings					
	Printer registration	Communication interface	IP address	Default gateway	Subnet mask	WPS <sup>*2</sup>	SSID <sup>*2</sup>
1. USB connection	○	/	/	/	/	/	/
2. Wired LAN connection	○ (Including IP address settings)	○	○	△ <sup>*1</sup>	△ <sup>*1</sup>	/	/
3. Wireless LAN connection	○ (Including IP address settings)	○	○	△ <sup>*1</sup>	△ <sup>*1</sup>	○	○

\*1: For wired/wireless LAN settings, set the default gateway and subnet mask if required.

\*2: When connecting with wireless LAN, perform connection setup through either WPS or SSID.

### MEMO

- When connecting to multiple computers, wired LAN and wireless LAN cannot be used at the same time. Set to either wired LAN or wireless LAN. To perform setup, on the main unit, access “Settings” - “Connection settings” - “01 Communication Interface,” then use “Wireless LAN” or “Wired LAN.”
- USB connections can be used in conjunction with “Wired LAN” or “Wireless LAN.” To perform setup, on the main unit, access “Settings” - “Connection settings” - “01 Communication Interface,” then use “Wireless LAN” or “Wired LAN.”
- A print driver is required for when using LM-550A3/550A2/550A.
- When using LM-550A3/550A2/550A, printer registration in LETATWIN PC EDITOR PRO is not required.
- LM-550A3/550A2/550A only support USB connection.

## 3-7-2 USB CONNECTION SETTINGS

Register the printer in LETATWIN PC EDITOR PRO.

Printer registration is required when using LM-3000PRO for the first time after installing LETATWIN PC EDITOR PRO.

- 1 Launch LETATWIN PC EDITOR PRO, select LM-3000PRO, then click the “Next” button.

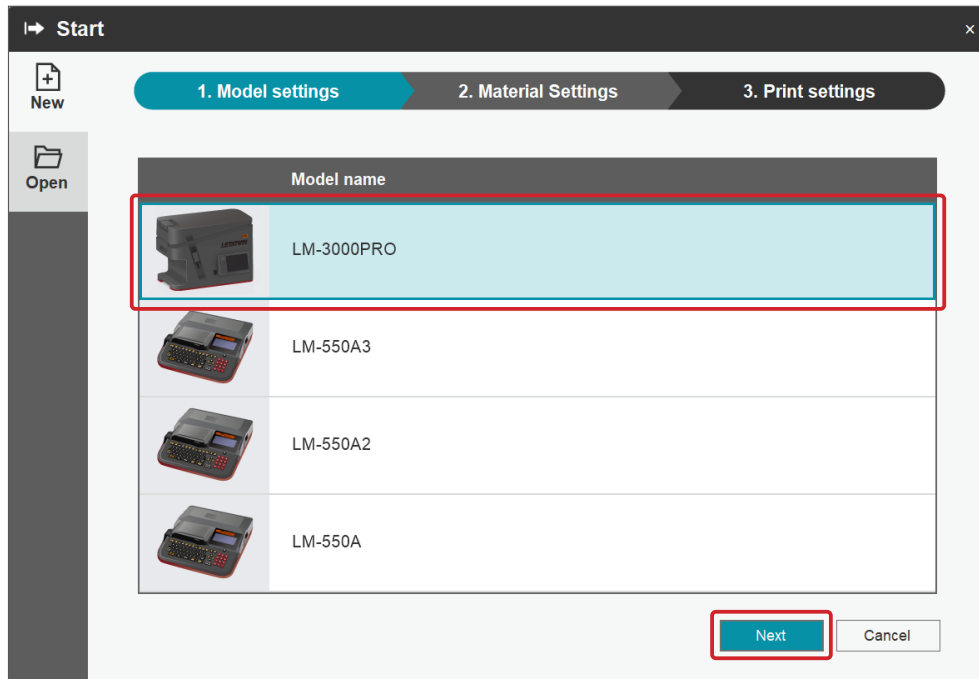

- 2 On the “Material settings” screen, select the desired material, then click the “Next” button.

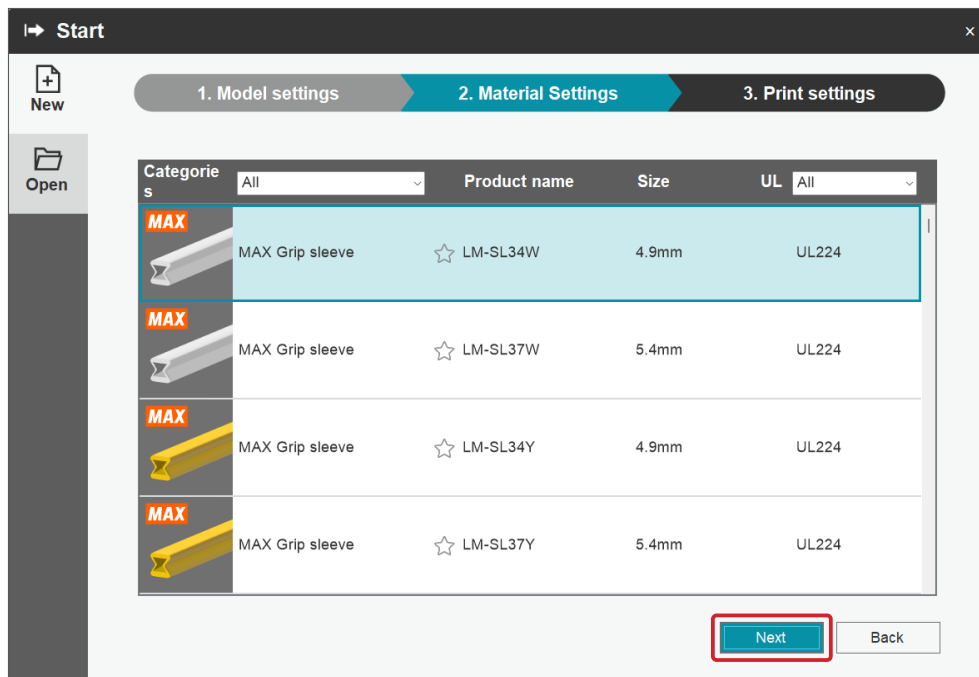

**3** On the “Print settings” screen, click the “OK” button.

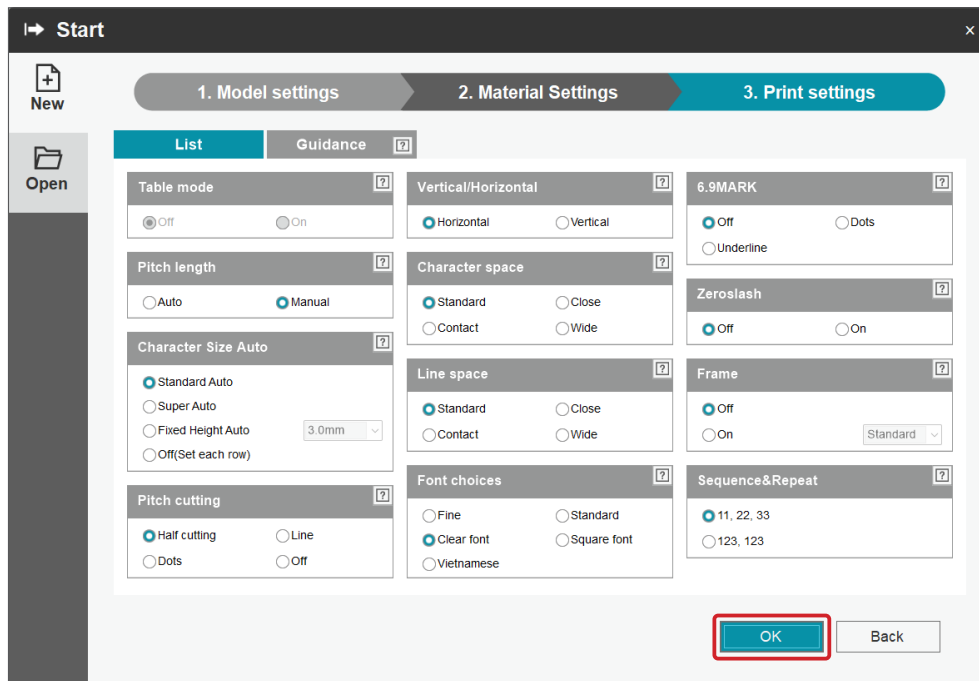

**4** Click “File” - “Printer registration.”

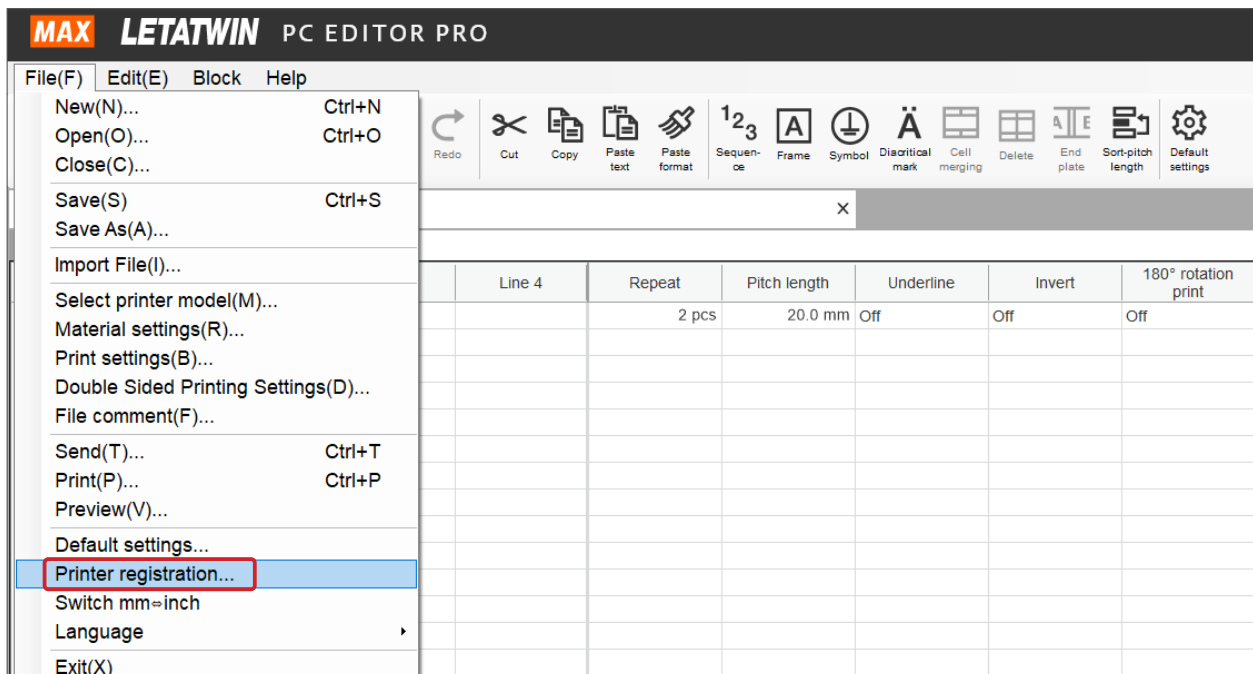

**5** Click on the USB cable connection field.

The screenshot shows a 'Printer registration' dialog box with two sections: 'LAN connection' and 'USB cable connection'. The 'LAN connection' section has a table with columns 'Printer name', 'IP address', and 'Timeout(Seconds)', a '+' button, and 'Delete' and 'Registration' buttons. The 'USB cable connection' section has a table with columns 'Printer name' and 'Timeout(Seconds)', and a 'Registration' button. A red box highlights the 'Printer name' and 'Timeout(Seconds)' columns in the USB section.

Printer name	IP address	Timeout(Seconds)

+

Delete Registration

---

**USB cable connection**

Printer name	Timeout(Seconds)

Registration

Close

**6** Enter the printer name, then click the "Registration" button.

The screenshot shows the same 'Printer registration' dialog box. In the 'USB cable connection' section, the 'Printer name' field now contains 'LM-3000PRO\_USB' and the 'Timeout(Seconds)' field contains '10'. The 'Registration' button is highlighted with a red box.

Printer name	IP address	Timeout(Seconds)

+

Delete Registration

---

**USB cable connection**

Printer name	Timeout(Seconds)
LM-3000PRO_USB	10

Registration

Close

**7** The printer is now registered. USB connection setup is now complete.

**Printer registration**

**LAN connection**

Printer name	IP address	Timeout(Seconds)

+ Delete Registration

**USB cable connection**

Printer name	Timeout(Seconds)
LM-3000PRO_USB	10

Registration

Close

**MEMO**

- To print from a computer, open the “Home” screen on the main unit before printing. Printing cannot be performed while on other screens other than the “Home” screen.
- When using a USB connection, only one computer and one LM-3000PRO can be connected.
- To connect one computer to multiple LM-3000PRO units or multiple computers to one LM-3000PRO, a LAN connection must be used.
- USB connections can be used in conjunction with LAN connections.

### 3-7-3 SETTING UP A WIRED LAN CONNECTION

To connect through a wired LAN, the following settings are required.

	LETATWIN PC EDITOR PRO setting	Main printer unit settings			
	Printer registration	Communication interface	IP address	Default gateway	Subnet mask
Wired LAN connection	○ (Including IP address settings)	○	○	△ *1	△ *1

\*1: Set the default gateway and subnet mask in the wired LAN settings as required.

- 1 Register the printer and IP address in LETATWIN PC EDITOR PRO.  
Printer registration is required when using LM-3000PRO for the first time after installing LETATWIN PC EDITOR PRO.  
Launch LETATWIN PC EDITOR PRO, select LM-3000PRO, then click the “Next” button.

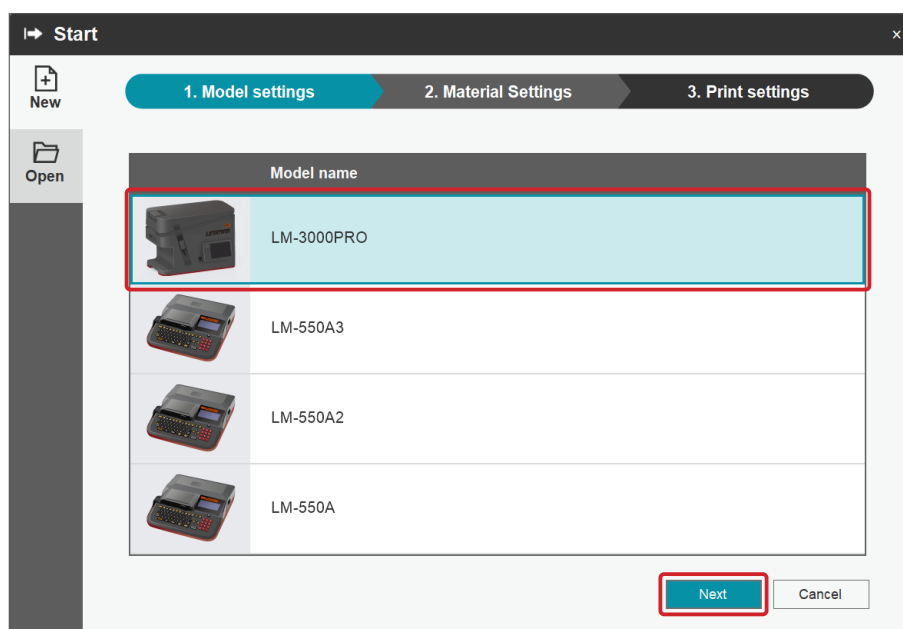

- 2 On the “Material settings” screen, select the desired material, then click the “Next” button.

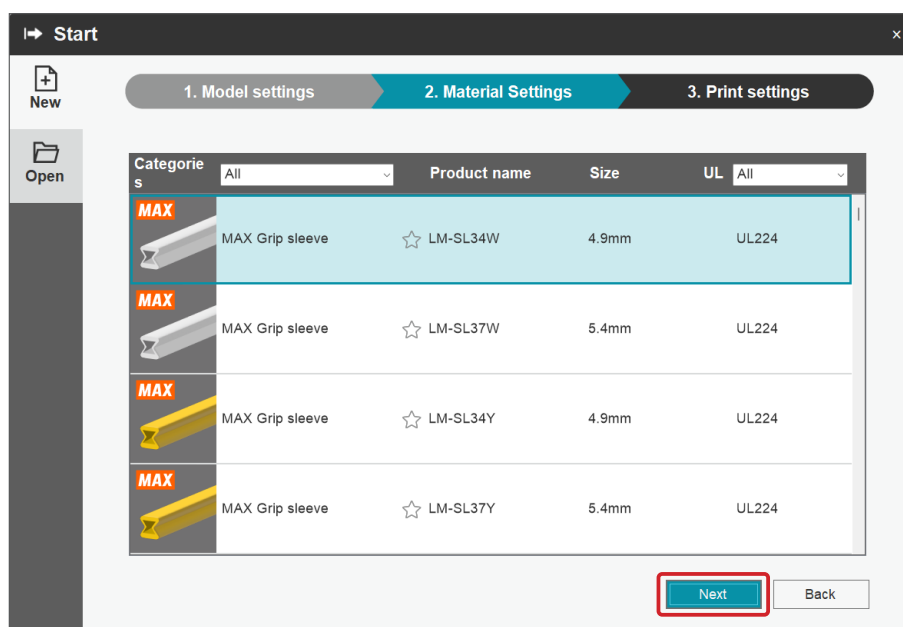

**3** On the “Print settings” screen, click the “OK” button.

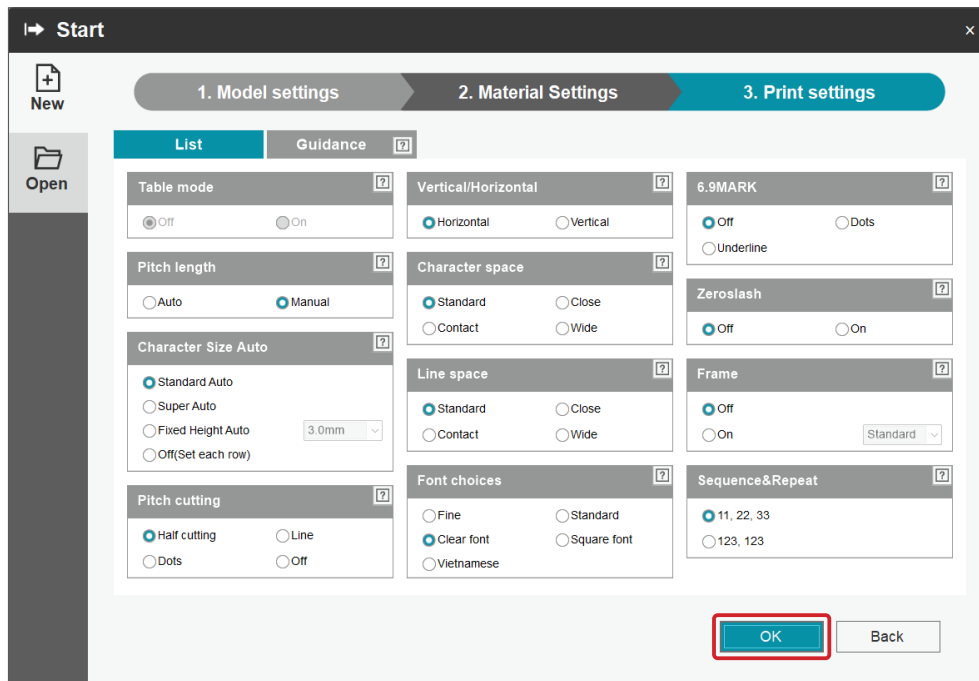

**4** Click “File” - “Printer registration.”

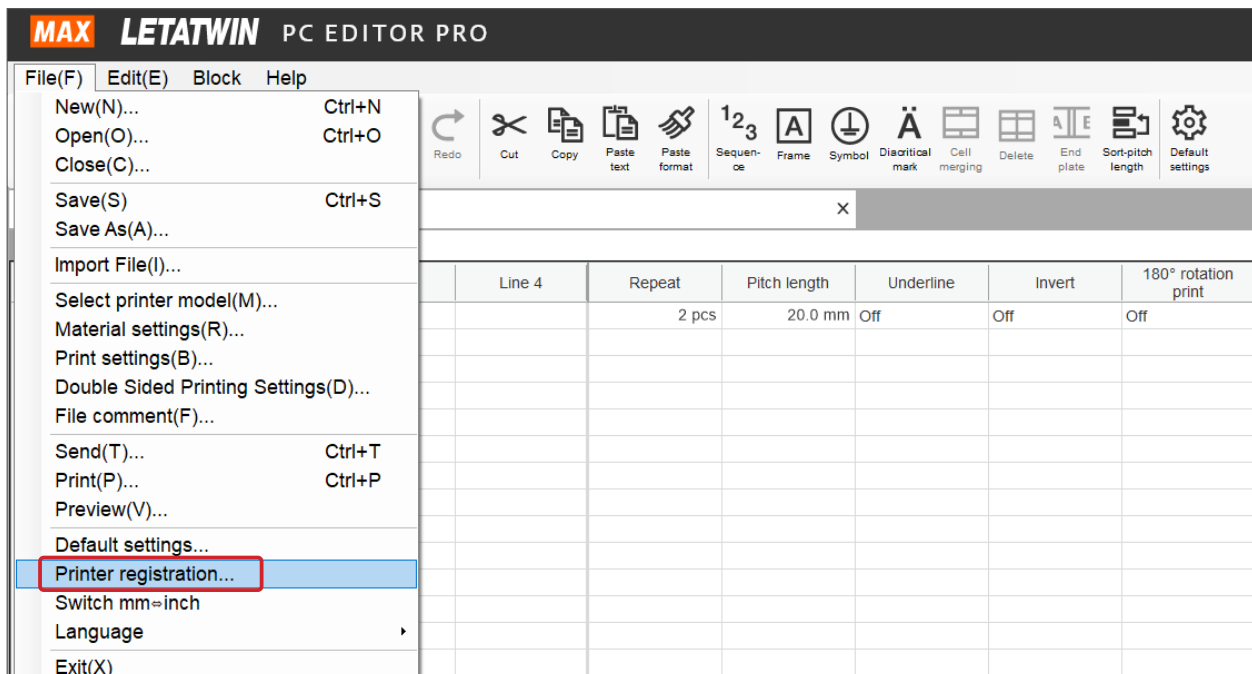

- 5 Click on the button for the LAN connection **+** field.

The screenshot shows a 'Printer registration' dialog box with a close button (x) in the top right corner. It is divided into two sections: 'LAN connection' and 'USB cable connection'. The 'LAN connection' section contains a table with three columns: 'Printer name', 'IP address', and 'Timeout(Seconds)'. A blue '+' button is located in the first row of this table, highlighted with a red box. To the right of the table are 'Delete' and 'Registration' buttons. The 'USB cable connection' section contains a table with two columns: 'Printer name' and 'Timeout(Seconds)'. A 'Registration' button is located below this table. At the bottom right of the dialog is a 'Close' button.

- 6 Double click on the IP address input field, enter the IP address, then click the “Registration” button.  
\*The printer name can be changed on this screen.

The screenshot shows the same 'Printer registration' dialog box. In the 'LAN connection' section, the table now has one row of data: 'LM-3000PRO\_LAN' in the 'Printer name' column, '192.168.11.1' in the 'IP address' column, and '10' in the 'Timeout(Seconds)' column. The entire row is highlighted with a red box. The 'Registration' button is also highlighted with a red box. The 'USB cable connection' section and the 'Close' button remain the same as in the previous screenshot.

**7** The printer is now registered.

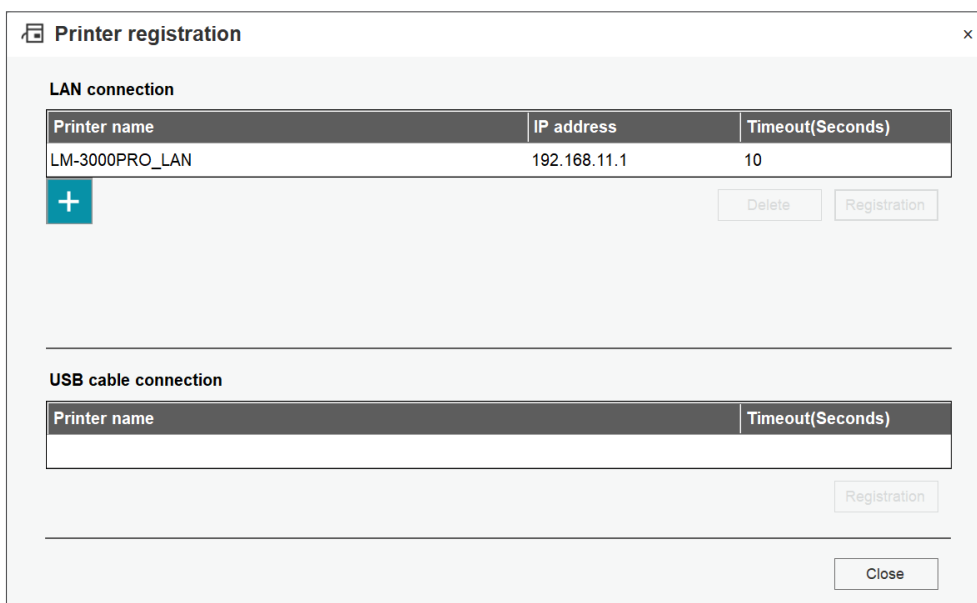

**MEMO**

- To print from a computer, open the “Home” screen on the main unit before printing. Printing cannot be performed while on other screens other than the “Home” screen.

**8** The communication interface can be switched on the main printer unit.  
Press “Settings.”

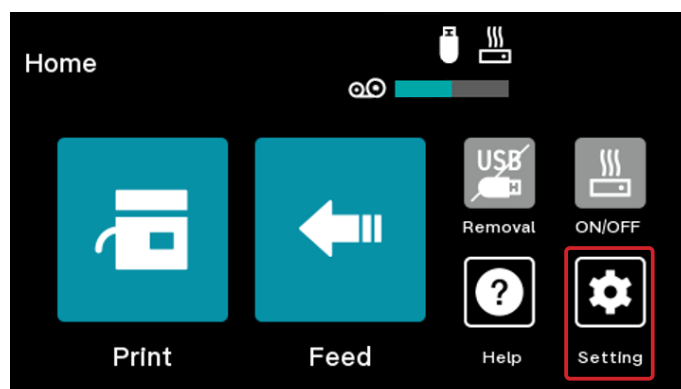

**9** Click the “Connection settings” button.

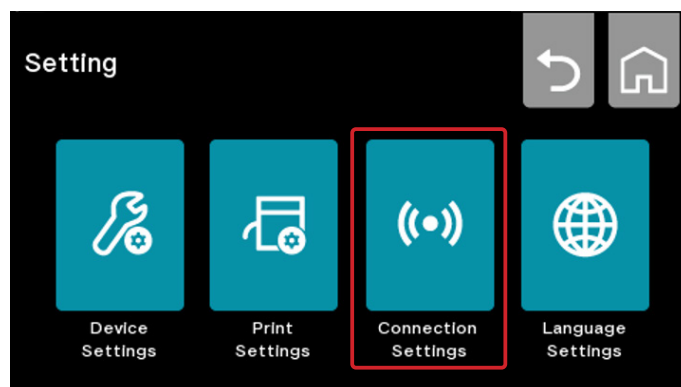

**10** Press “01 Communication interface.”

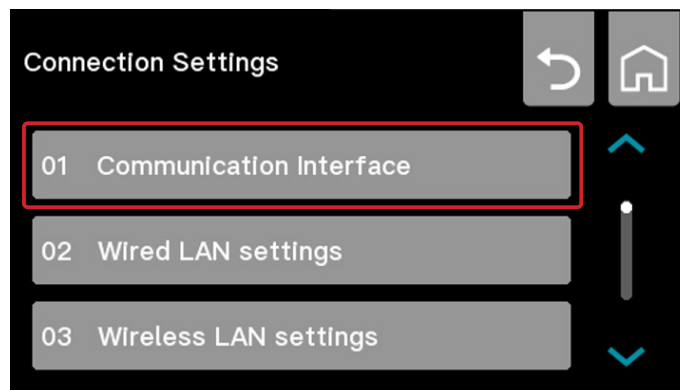

**11** Press “Wired,” then press the “OK” button.  
After restarting, please proceed from step 12.

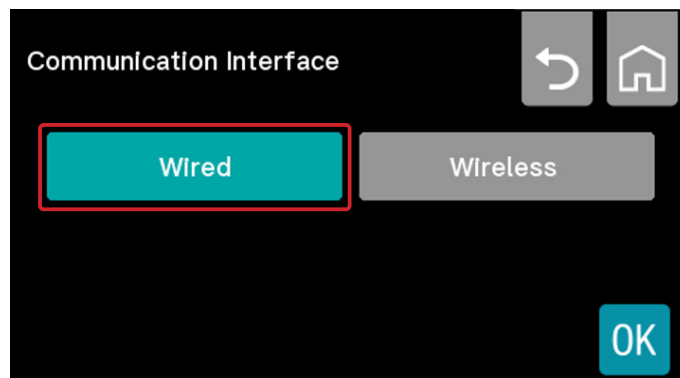

**12** Set the IP address for the main unit.  
Press the “02 Wired LAN settings” button on the “Connection settings” screen.

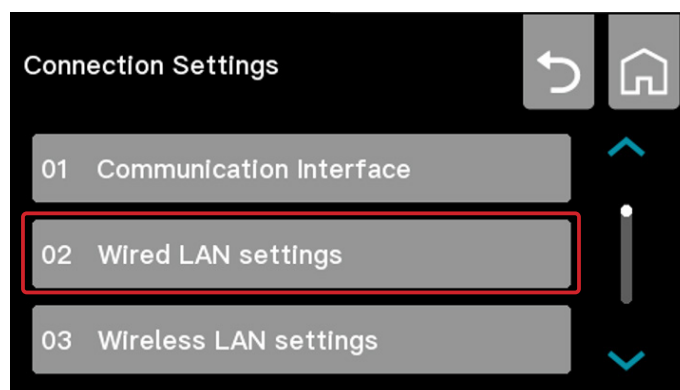

**13** Set the “IP address,” “Default gateway” and “Subnet mask.”

\*Set the default gateway and subnet mask as required.

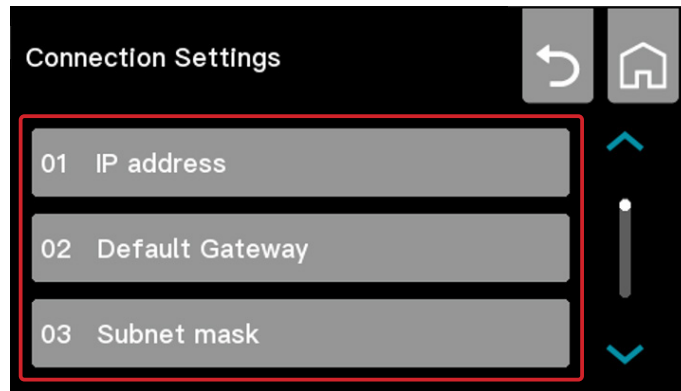

Input a numerical value, then press the “OK” button.

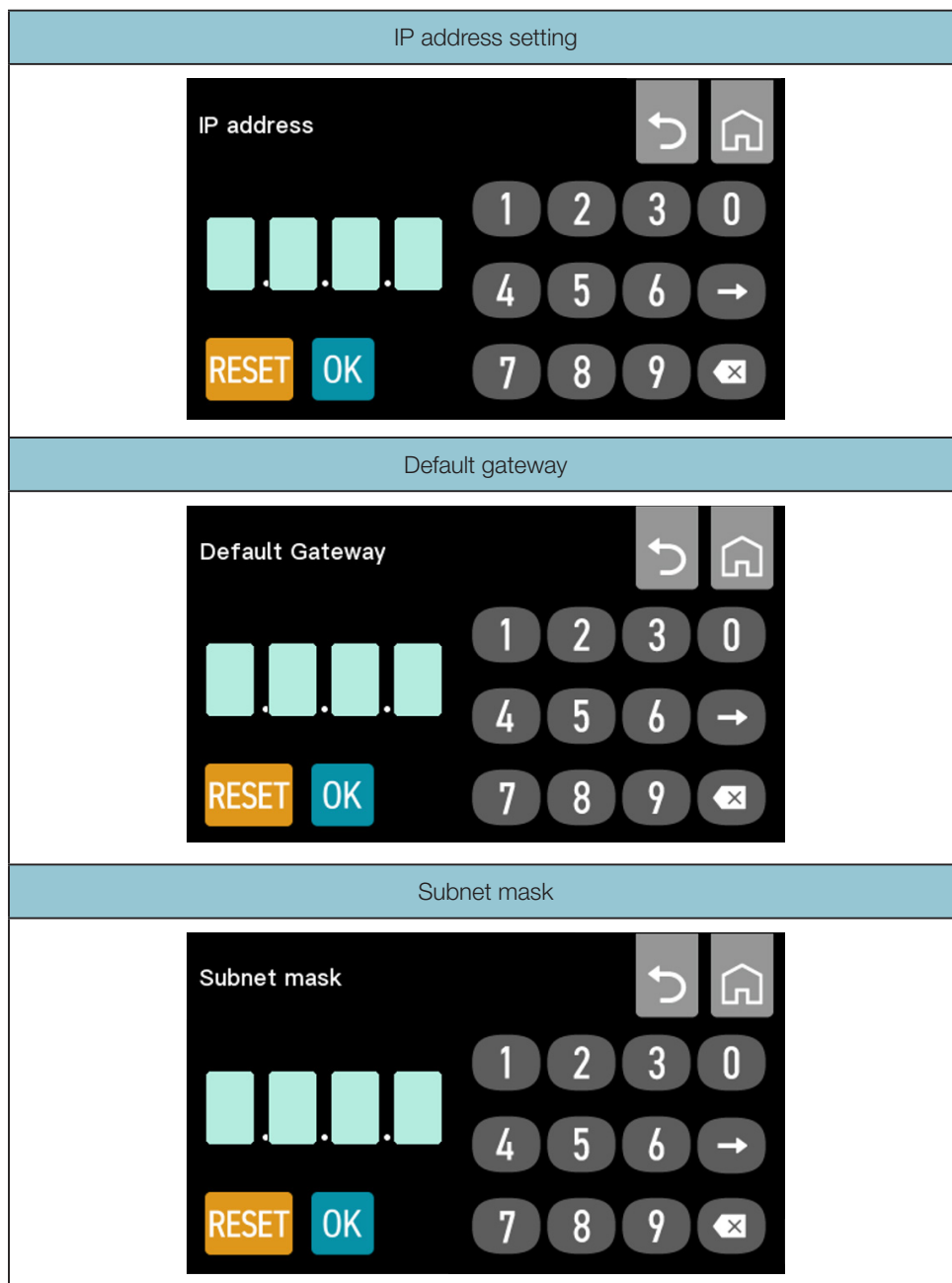

14 Please press the  or  button.

Please turn off the device to apply the settings. After turning it off, please turn it back on.

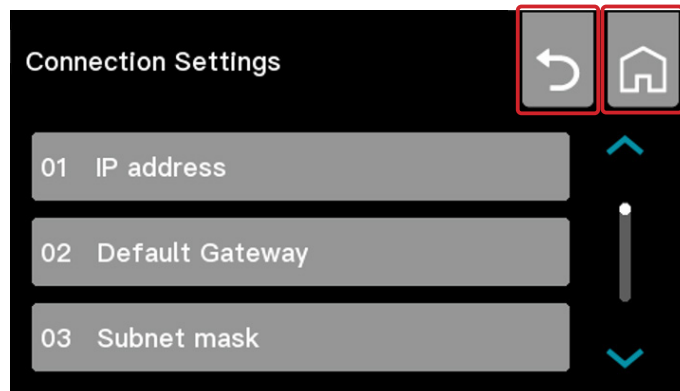

15 After restarting, if the  symbol is lit, wired LAN connection is operating with the applied settings.

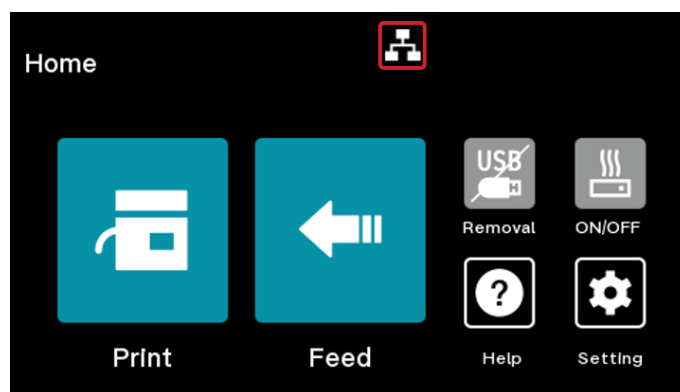

 **MEMO**

- To print from a computer, open the “Home” screen on the main unit before printing. Printing cannot be performed while on other screens other than the “Home” screen.

## 3-7-4 SETTING UP A WIRELESS LAN CONNECTION

To connect through a wireless LAN, the following settings are required.

	LETATWIN PC EDITOR PRO setting	Main printer unit settings					
	Printer registration	Communication interface	IP address	Default gateway	Subnet mask	WPS*1	SSID*1
Wireless LAN connection	<input type="radio"/> (Including IP address settings)	<input type="radio"/>	<input type="radio"/>	<input type="checkbox"/> *2	<input type="checkbox"/> *2	<input type="radio"/>	<input type="radio"/>

\*1: When connecting with wireless LAN, perform connection setup through either WPS or SSID.

\*2: Set the default gateway and subnet mask in the wireless LAN settings as required.

- 1** Register the printer and IP address in LETATWIN PC EDITOR PRO.  
 Printer registration is required when using LM-3000PRO for the first time after installing LETATWIN PC EDITOR PRO.  
 Launch LETATWIN PC EDITOR PRO, select LM-3000PRO, then click the “Next” button.

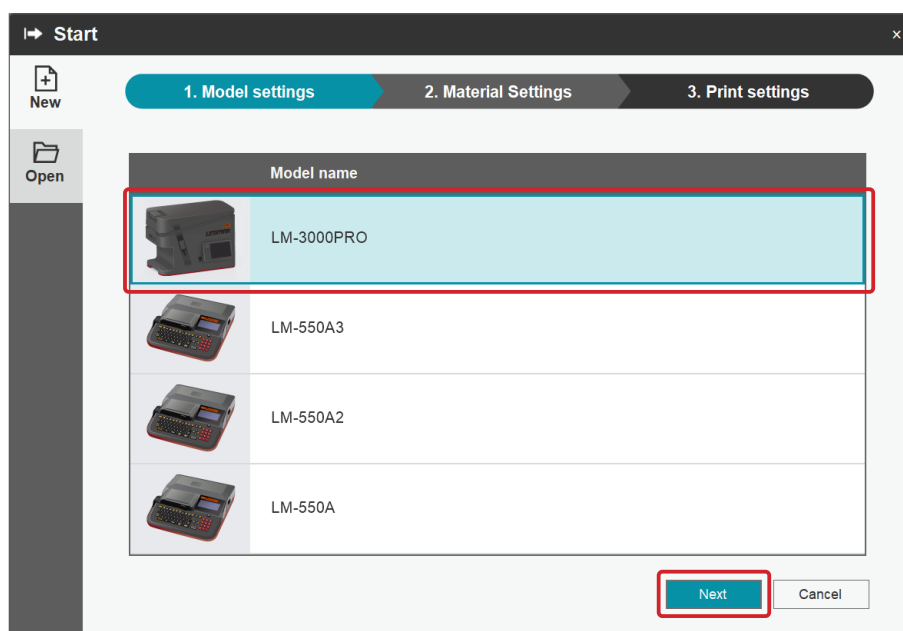

- 2** On the “Material settings” screen, select the desired material, then click the “Next” button.

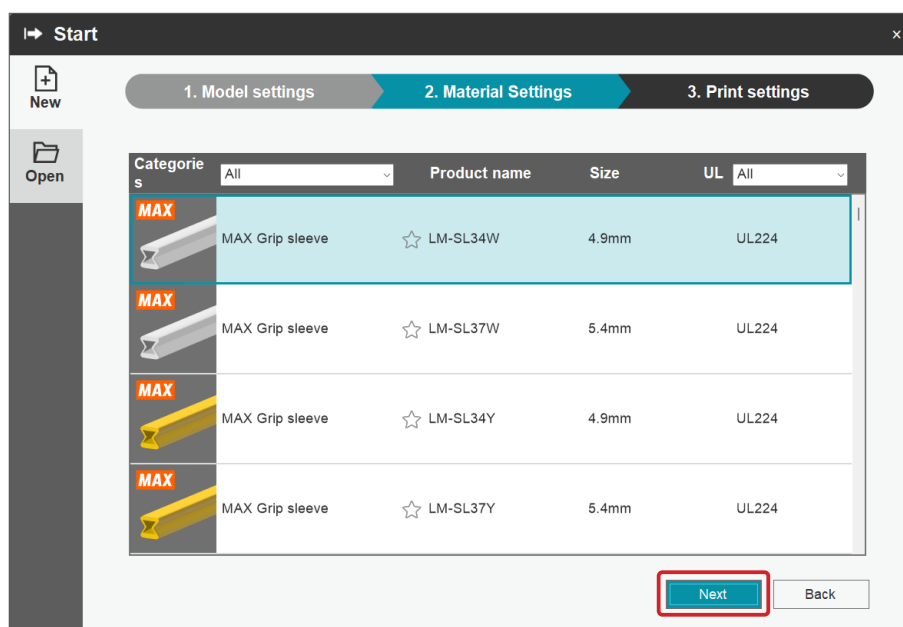

**3** On the “Print settings” screen, click the “OK” button.

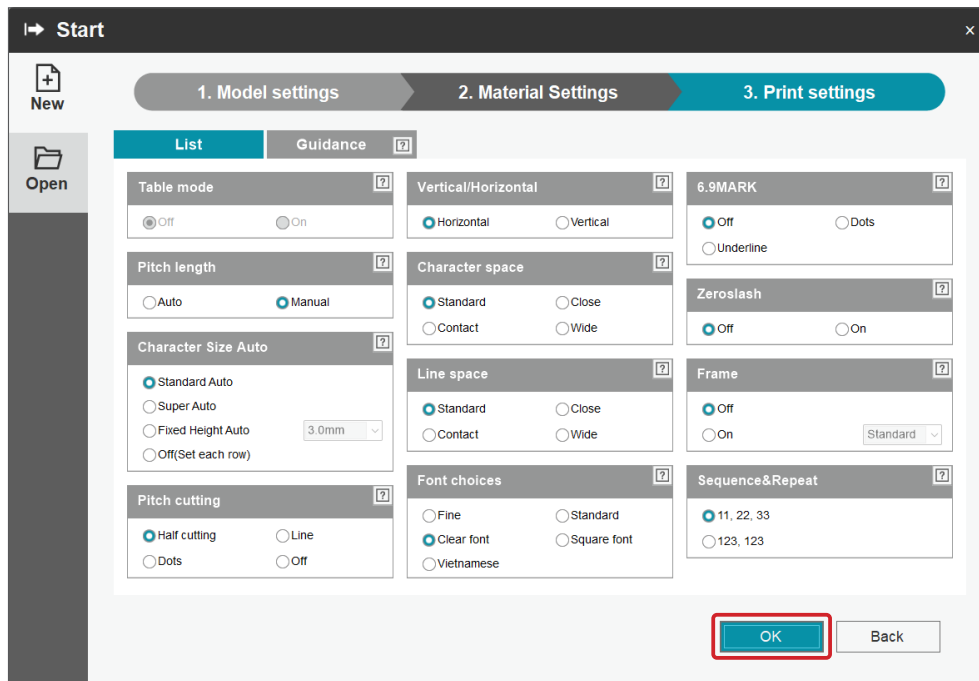

**4** Click “File” - “Printer registration.”

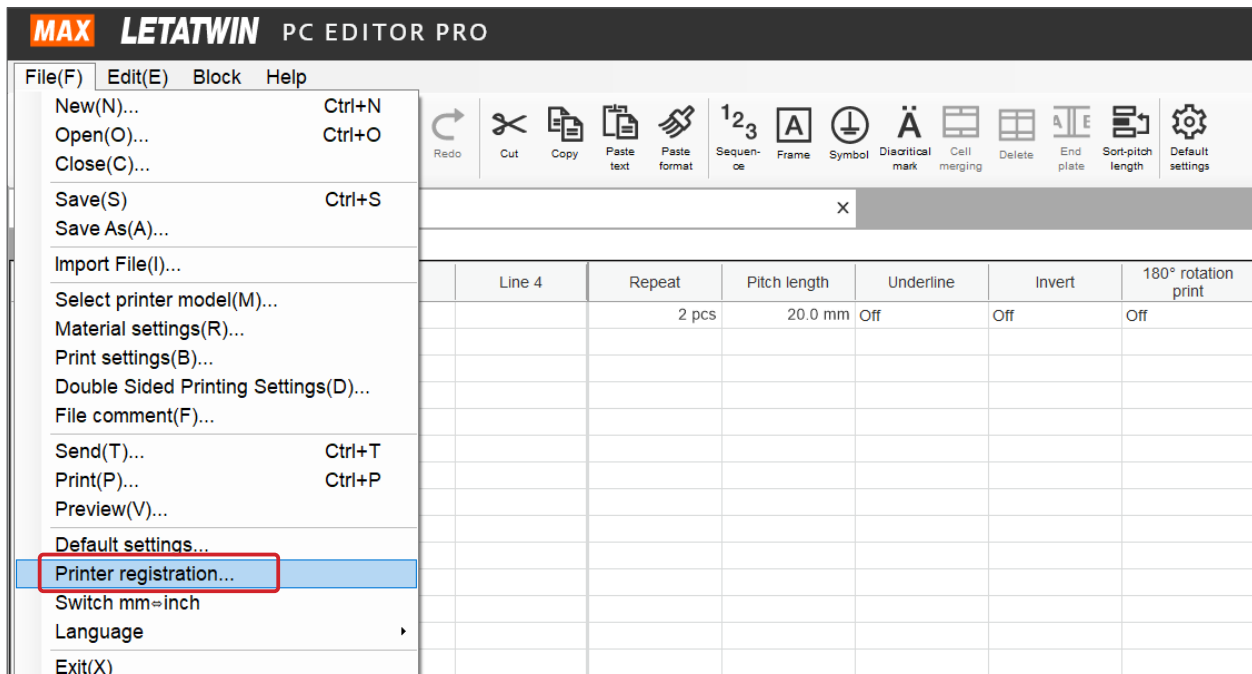

- 5 Click on the button for the LAN connection **+** field.

The screenshot shows a window titled "Printer registration" with a close button (x) in the top right corner. It is divided into two sections: "LAN connection" and "USB cable connection".

**LAN connection section:**

Printer name	IP address	Timeout(Seconds)
+		

Buttons: Delete, Registration

**USB cable connection section:**

Printer name	Timeout(Seconds)

Buttons: Registration, Close

- 6 Double click on the IP address input field, enter the IP address, then click the "Registration" button.  
\*The printer name can be changed on this screen.

The screenshot shows the same "Printer registration" window. In the "LAN connection" section, a table now contains one entry:

Printer name	IP address	Timeout(Seconds)
LM-3000PRO_LAN	192.168.11.1	10

Buttons: Delete, Registration

The "Registration" button is highlighted with a red box. The "USB cable connection" section remains empty.

**7** The printer is now registered.

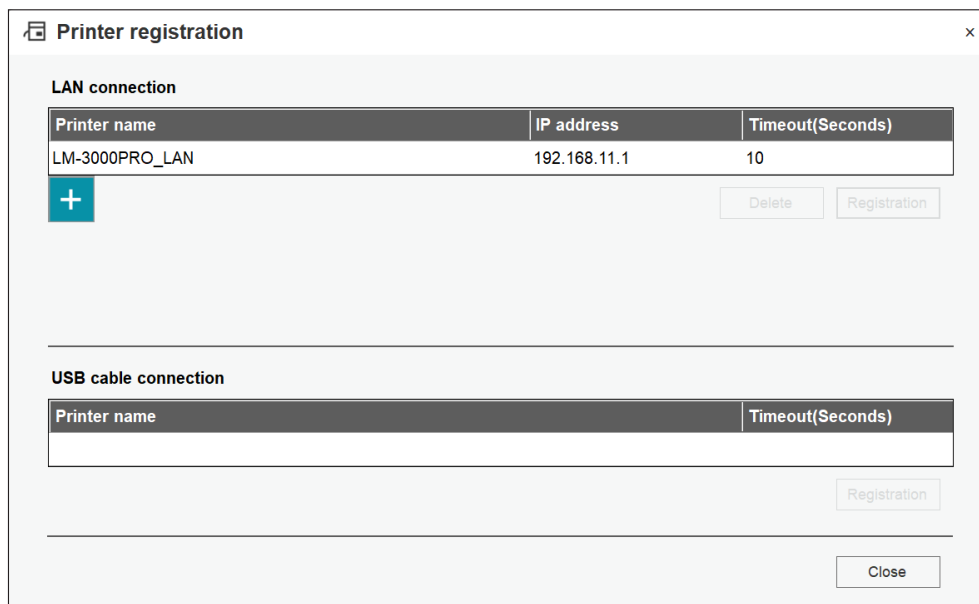

**8** The communication interface can be switched on the main printer unit. Press “Settings.”

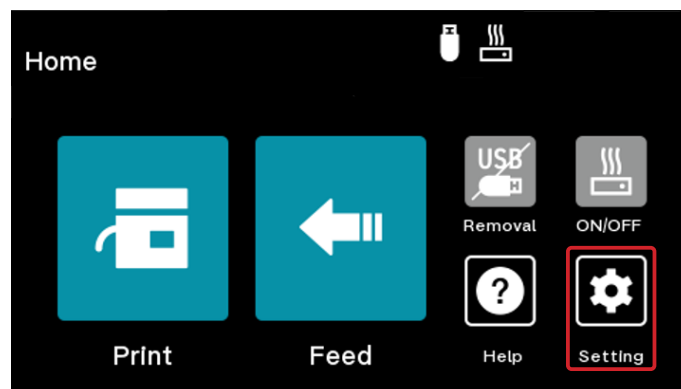

**9** Click the “Connection settings” button.



**10** Press “01 Communication interface.”

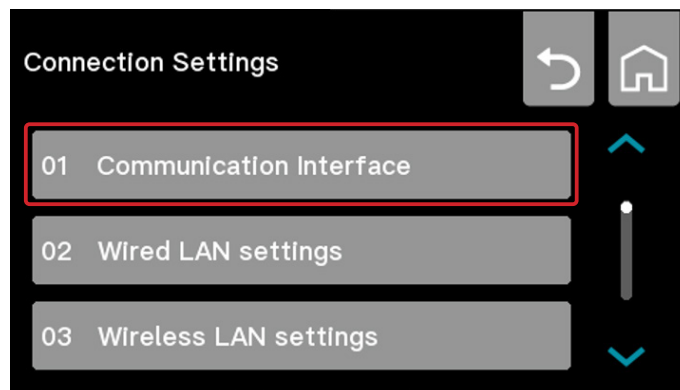

**11** “Wireless” then press the “OK” button.  
After restarting, please proceed from step 12. Press

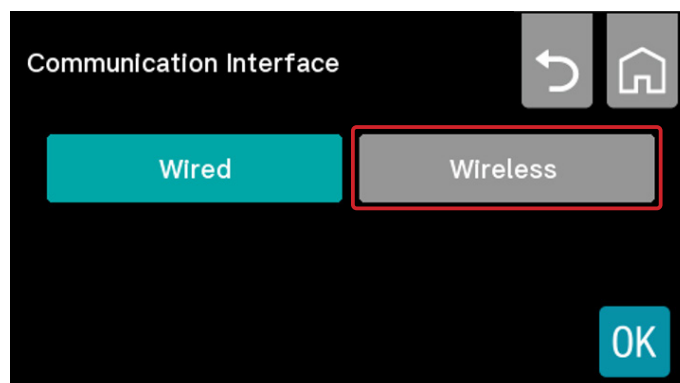

**12** Set the IP address for the main unit.  
Press the “03 Wireless LAN settings” button on the “Connection settings” screen.

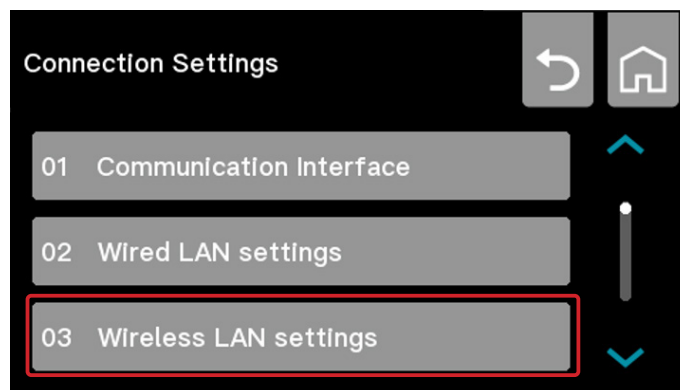

- 13** Set the “IP address,” “Default gateway” and “Subnet mask.”  
\*Set the default gateway and subnet mask as required.

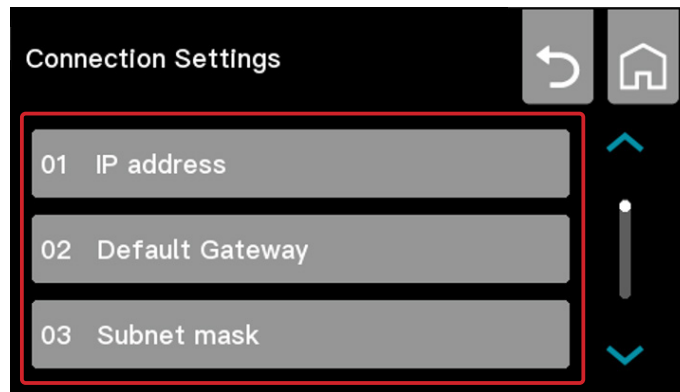

\*When setting up a connection through SSID, the following settings are required.

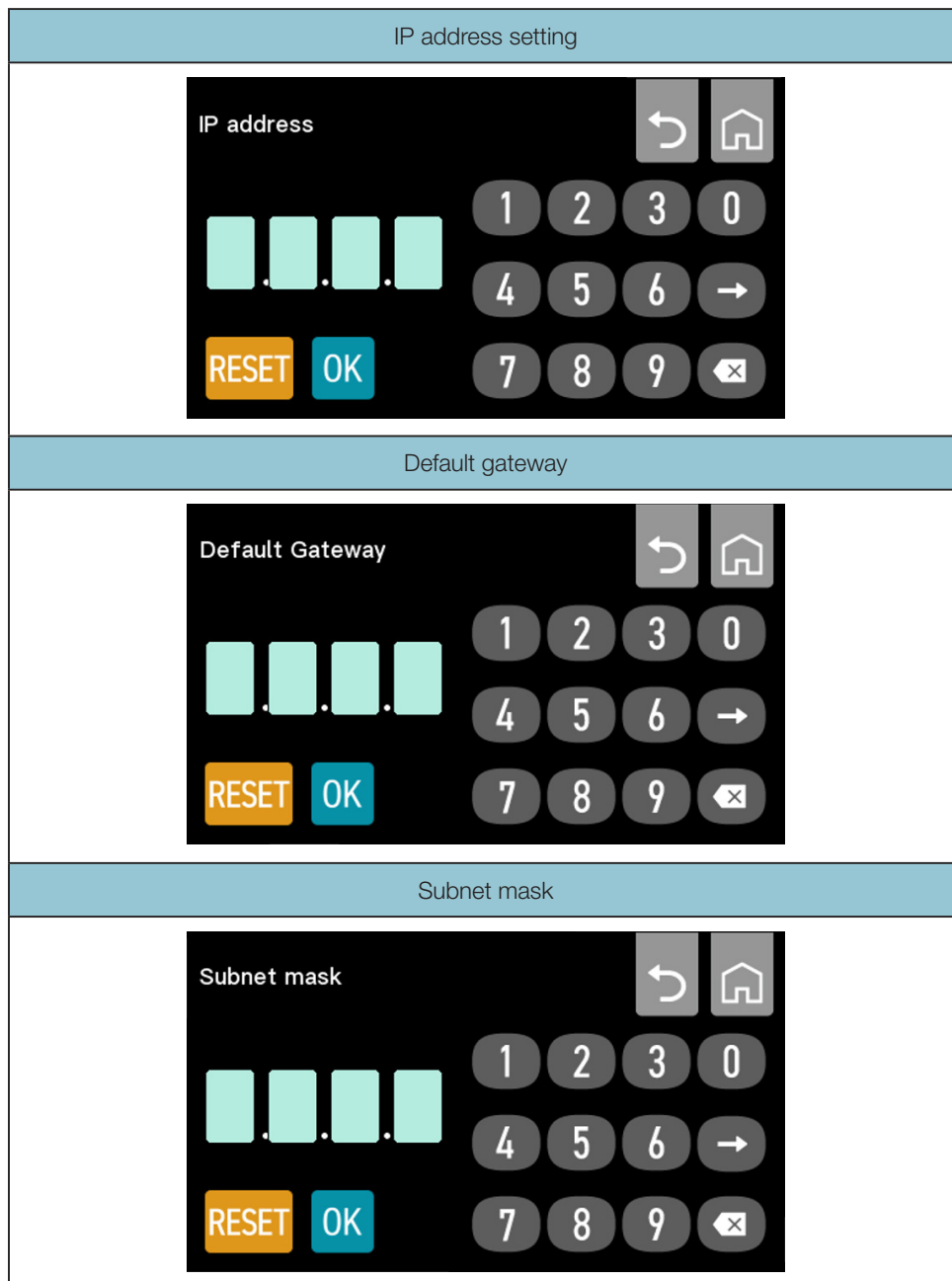

**14** When connecting with wireless LAN connection setup through either WPS or SSID.

Performing connection setup through “WPS”:

(1) On the “Wireless LAN settings” screen, press “04 WPS.”

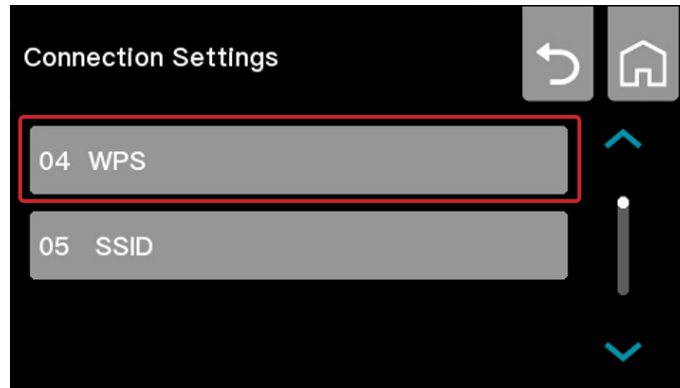

(2) Press the router button.

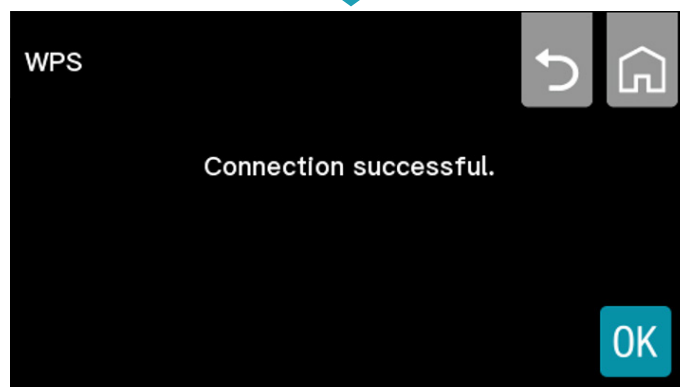

\*Repeat these steps in the event that the connection is lost.

(3) Please press the  or  button.

Please turn off the device to apply the settings. After turning it off, please turn it back on.

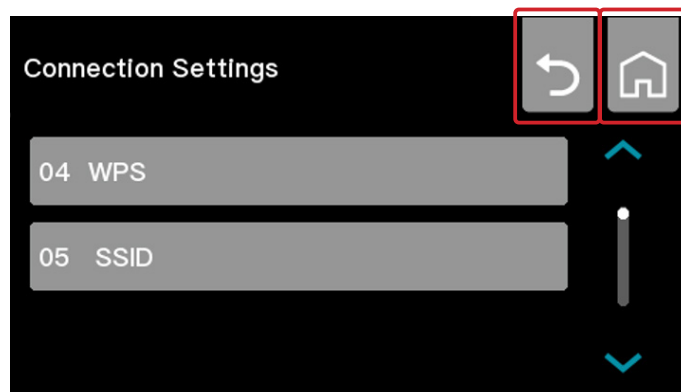

(4) After restarting, if the  symbol is lit, connection has been successfully completed.

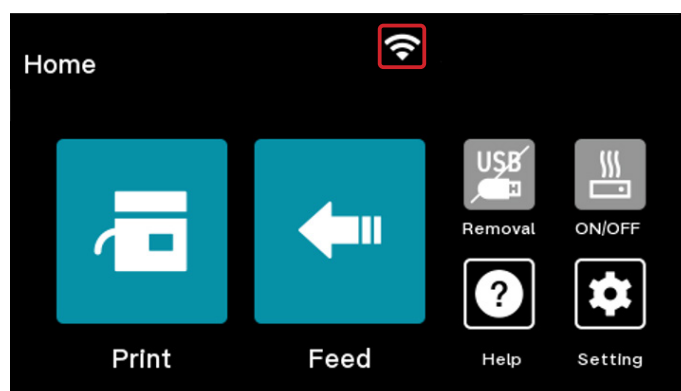

#### Performing connection setup through SSID:

A USB memory device is required to perform connection setup through SSID.

To enter the SSID password, the main unit writes a specially-formatted file to the USB memory device, then reads this file to check the password.

(1) On the “Wireless LAN settings” screen, press “05 SSID.”

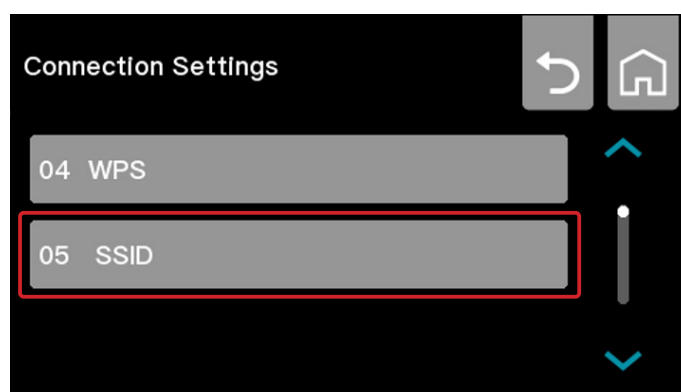

(2) Perform SSID setup either manually or automatically.

Manual setup:

① Press "01 Manual."

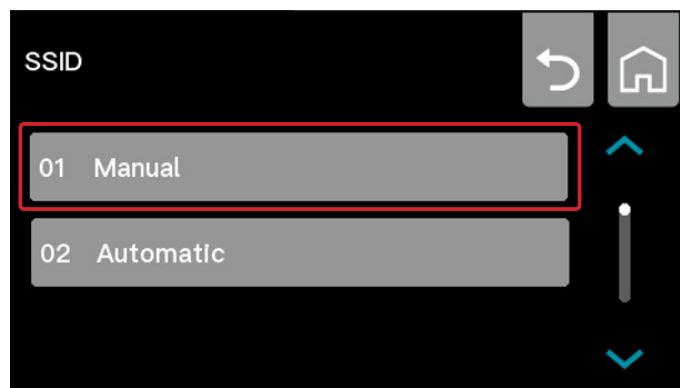

② Insert the USB memory device into the main unit and press the "Output" button. A text file for password input is written to the USB memory device.

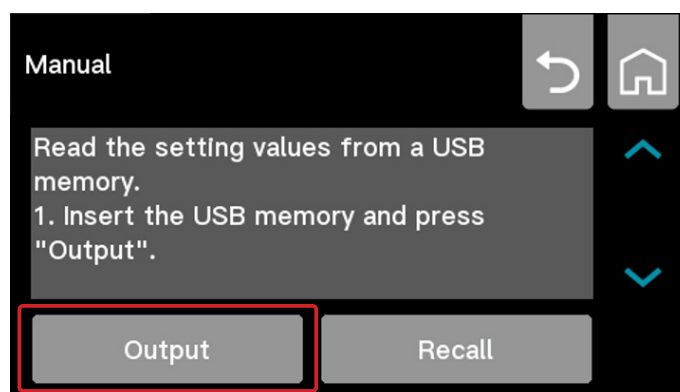

③ Use a computer to open the text file in the USB memory device, input the network name, security type and password, then overwrite the file by saving it. Enter in accordance with the example input in the text file.

Network Name :  
 Security method :  
 password :

---

Please enter the network name, security method, and password above using the example below as a reference, then overwrite and save.

[Example]  
 Network name : MAX\_LAN  
 Security method : 2  
 Password : maxlan

- Network name  
Enter the SSID of your Wi-Fi router.
- Security method  
Select the type of security set in the Wi-Fi router.  
Please enter the corresponding number for the security method below.
- 1 : WPA-PSK/WPA2-PSK
- 2 : Disabled encryption
- Password  
Enter the password for your Wi-Fi router.

- ④ Insert the USB memory device into the main unit, then press “Load.” After loading, the machine restarts.

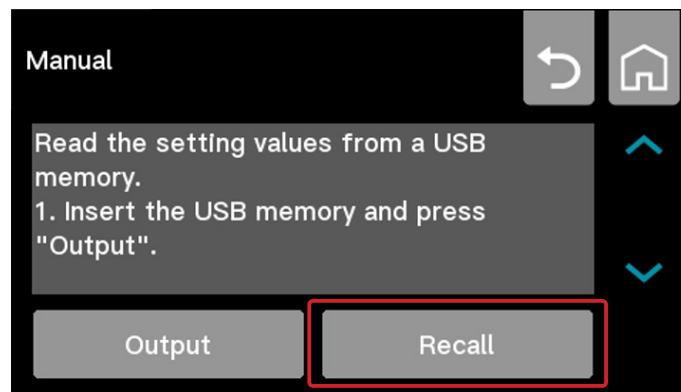

- ⑤ After restarting, if the  symbol is lit, connection has been successfully completed.

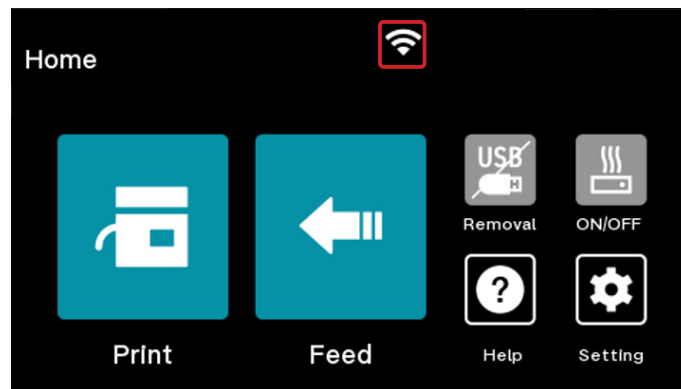

Automatic setup:

- ① Press “02 Auto.”

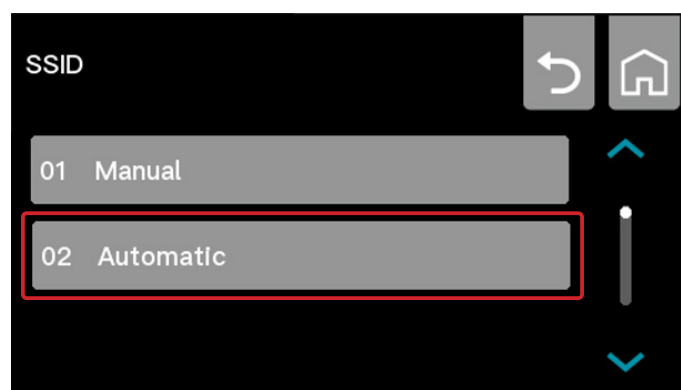

- ② Select the SSID to be connected.

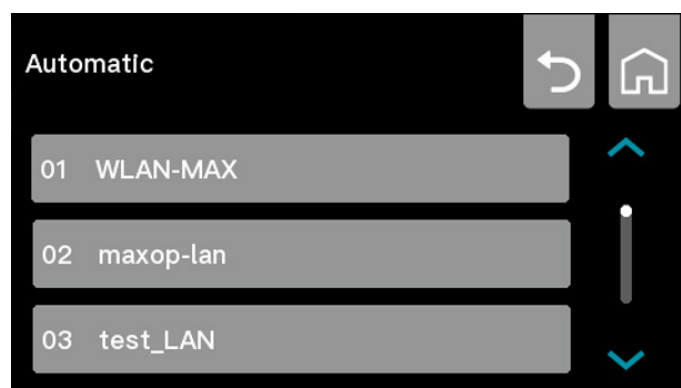

- ③ Insert the USB memory device into the main unit and press the “Output” button.  
A text file for password input is written to the USB memory device.

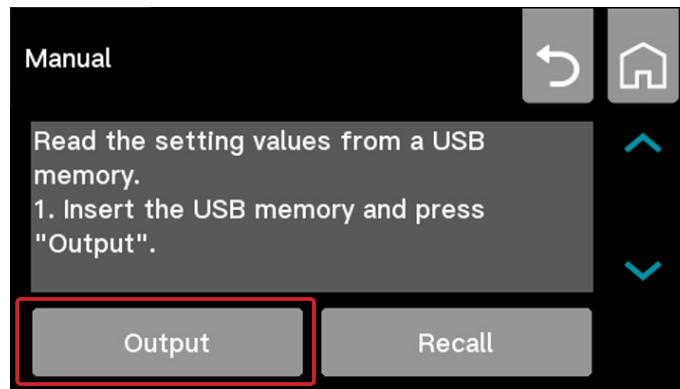

- ④ Use a computer to open the text file in the USB memory device, input the password, then overwrite the file by saving it.

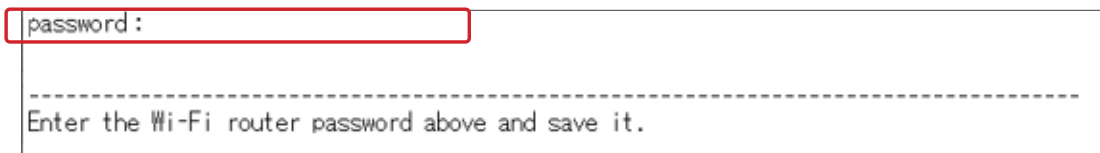

- ⑤ Insert the USB memory device into the main unit, then press “Load.” After loading, Please turn off the device to apply the settings. After turning it off, please turn it back on.

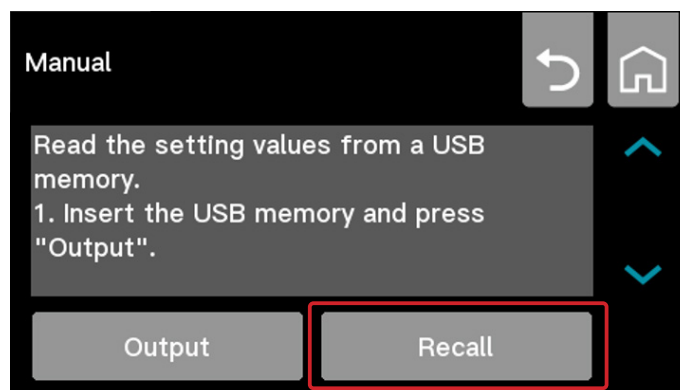

- ⑥ After restarting, if the  symbol is lit, connection has been successfully completed.

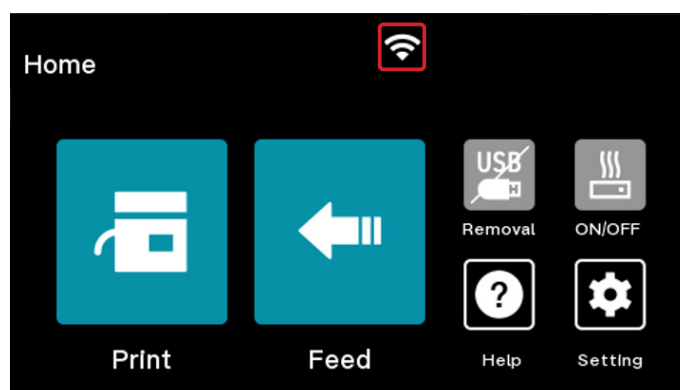

## 3-8 DOWNLOADING AND INSTALLING LETATWIN PC EDITOR PRO

The dedicated software LETATWIN PC EDITOR PRO is required to use this product. From the “My page” login screen, perform “New purchase registration” or “User registration.” Then, download and install LETATWIN PC EDITOR PRO after confirming the installation method on the designated page. LETATWIN PC EDITOR PRO can be downloaded free of charge from the URL below.

<https://www.max-ltd.co.jp/int/letatwinfan-lm-3000pro/>

### MEMO

- A print driver is not required to print with LM-3000PRO.
- LETATWIN PC EDITOR PRO can also be used with LM-550A3/550A2/550A.
- When using LETATWIN PC EDITOR PRO to print with LM-550A3/550A2/550A, a separate print driver must be installed.

### ■ Serial number indication

The serial number indication is attached to the side of the main unit.

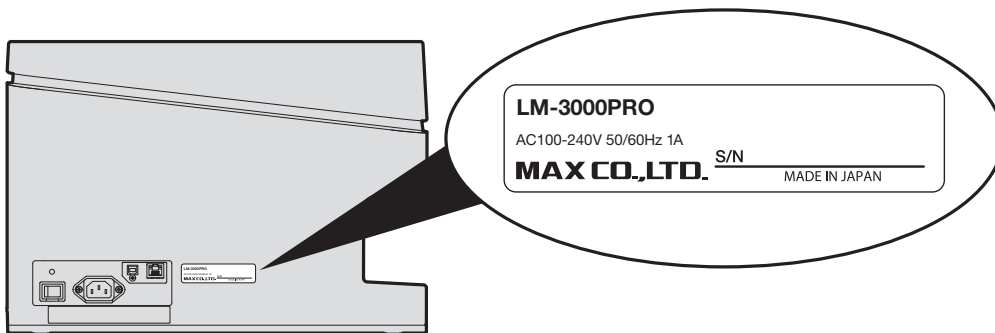

# 3-9 BLOCKS AND PITCH LENGTH/PITCH PRINT

This section explains “blocks” and “pitch length/pitch print,” which are required to use the machine.

## ■ Block

A “block” is the entire set of characters that is printed on one tube or one label.

A maximum of 2000 blocks can be input.

## ■ Pitch length

The “pitch length” is the length of one block.

## ■ Pitch print

“Pitch print” is printing with a set pitch length. The pitch length can be changed for each block.

→ 3-11 AVAILABLE PITCH LENGTH SETTINGS

### Example of printing

Tubes

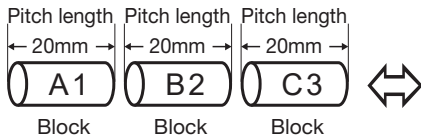

### Screen display

MAX LETATWIN PC EDITOR PRO

File(F) Edit(E) Block Help

LMPC1

	Line 1	Line 2	Line 3	Line 4	Repeat	Pitch length	Underline	Invert	180° rotation print
1	A1				1 pcs	20.0 mm	Off	Off	Off
2	B2				1 pcs	20.0 mm	Off	Off	Off
3	C3				1 pcs	20.0 mm	Off	Off	Off
4									
5									
6									

Tubes

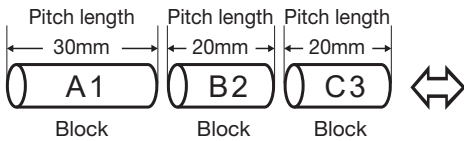

MAX LETATWIN PC EDITOR PRO

File(F) Edit(E) Block Help

LMPC1

	Line 1	Line 2	Line 3	Line 4	Repeat	Pitch length	Underline	Invert	180° rotation print
1	A1				1 pcs	30.0 mm	Off	Off	Off
2	B2				1 pcs	20.0 mm	Off	Off	Off
3	C3				1 pcs	20.0 mm	Off	Off	Off
4									
5									
6									

# 3-10 PRINT AREA

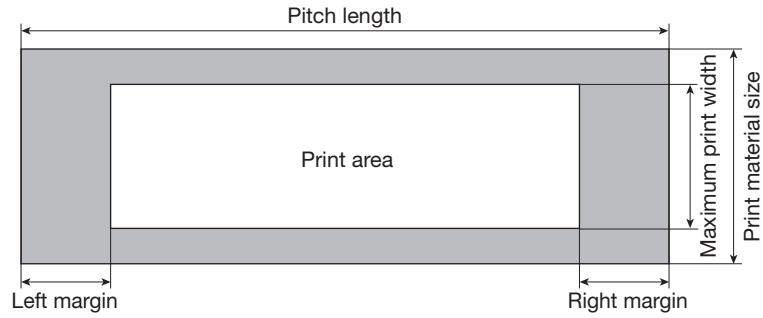

Print material	Size	Left/right margins	Maximum print width
MAX grip sleeve	4.9mm(LM-SL34)	2.0mm each	3.0mm
	5.4mm(LM-SL37)		3.4mm
MAX grip tube	φ2.9		2.9mm
	φ3.7		3.8mm
	φ4.6		4.2mm
MAX tube	φ2.5, φ2.7		2.9mm
	φ3.2, φ3.4, φ3.6		3.8mm
	φ4.2		3.9mm
	φ5.2, φ6.4		4.6mm
	φ8.0		6.6mm
Shrinkable tubes	φ2.0		2.0mm each
	φ2.5, φ3.0	2.9mm	
	φ3.5, φ4.0	3.8mm	
	φ4.5	3.9mm	
	φ5.0	4.6mm	
	φ5.5, φ6.0, φ6.5, φ7.0, φ7.5, φ8.5, φ9.5, φ10.5, φ11.5, φ12.5, φ13.5, φ14.5, φ15.5, φ16.5, φ17.5, φ19.0	6.6mm	
Generic tubes	φ1.5, φ2.0	2.0mm each	1.3mm
	φ2.5		2.9mm
	φ3.2, φ3.6		3.8mm
	φ4.2		3.9mm
	φ5.2, φ5.5, φ6.0, φ6.5		4.6mm
	φ8.0, φ10.0		6.6mm
MAX tape	5.0mm	1.0mm each	2.9mm
	9.0mm		7.4mm
	12.0mm		9.8mm
MAX marking plate	8.5mm	0.5mm each	6.9mm
	9.5mm		7.4mm
	10.0mm		7.9mm
	10.7mm		8.6mm
Generic marker strips	5.5mm	0.5mm each	3.1mm
	6.2mm		4.0mm
	6.5mm		4.4mm
	7.5mm		5.5mm
	8.0mm		6.6mm
	8.5mm		6.9mm
	9.5mm		7.4mm
	10.0mm		7.9mm
	10.7mm, 11.0mm		8.6mm
12.0mm	9.8mm		
ID plates	4.1mm		2.0mm
Block markers	113, 114, 115		6.8mm
	145		2.9mm
	515		8.4mm
	615		7.9mm

## 3-11 AVAILABLE PITCH LENGTH SETTINGS

Print material	Available pitch length settings
MAX grip sleeve	10 to 150mm
MAX grip sleeve double-sided printing	20 to 150mm
MAX grip tube	10 to 150mm
MAX tube	10 to 150mm
Shrinkable tubes	5 to 500mm
Generic tubes	10 to 150mm
MAX tape	3.5 to 60mm
MAX marking plate	2.5 to 60mm
Generic marker strips	2.5 to 60mm
MAX ID plates	4.0 to 60mm
Block markers	Setting cannot be changed

## 3-12 MAXIMUM PRINT LENGTH

	Maximum print length (m)	
	Single copy	Multiple copies
MAX grip sleeve	100	100
Tubes	100	100
MAX tape	5	10
MAX marking plate	5	10
Generic marker strips	5	10
MAX ID plates	20	20
Block markers	1,000 (pieces)	1,000 (pieces)

# Chapter 4

## OPERATING THE MAIN UNIT AND LOADING CONSUMABLES

---

4-1 FULL CUTTING .....	51
4-2 ADJUSTING THE HALF CUTTING DEPTH.....	51
4-3 ADJUSTING THE PRINTING PRESSURE.....	52
4-4 LOADING GRIP SLEEVES.....	53
4-5 LOADING TUBES AND ID PLATES.....	55
4-5-1 SETTING THE TUBE HEATER IN POSITION.....	57
4-5-2 LOADING MAX GRIP TUBES, MAX TUBES AND GENERIC .....	59
4-5-3 MOUNTING ATTACHMENTS FOR USE WITH THIN TUBES AND THICK TUBES....	60
4-6 CHANGING THE EXIT GUIDE.....	61
4-7 LOADING TAPE AND MARKER STRIPS .....	62
4-8 LOADING BLOCK MARKERS.....	66
4-9 INSTALLING THE INK RIBBON.....	69
4-10 INSTALLING THE REEL STAND.....	71

## 4-1 FULL CUTTING

After printing is complete, pull the full cut lever down to perform full cutting.

Full cutting cannot be performed on marker strips or block markers. Remove them and cut them with scissors.

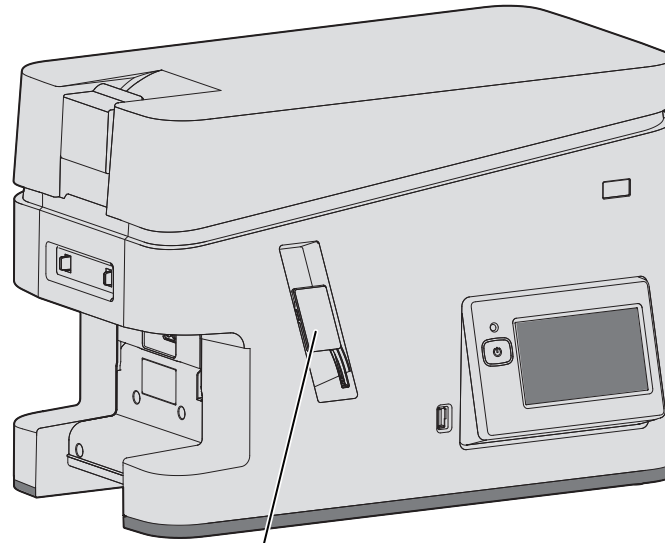

Full cutting lever

## 4-2 ADJUSTING THE HALF CUTTING DEPTH

When adjusting the half cutting depth, a higher number on the adjustment lever scale denotes deeper cutting and a lower number denotes shallower cutting.

For tape, set the scale to a large number (deep cut.)

Adjust based on the size and type of print material.

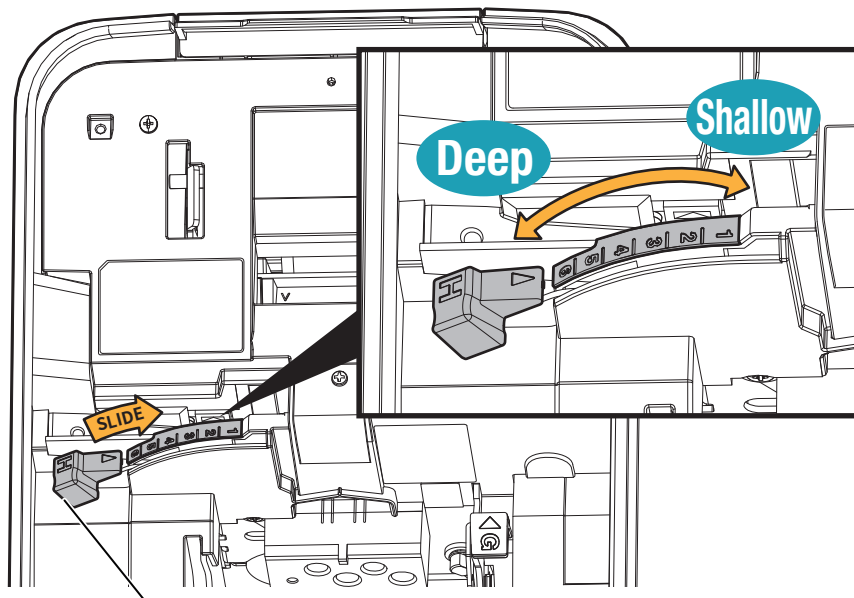

Half cutter depth adjustment lever

### MEMO

- If the half cut is too deep, the consumable may be completely severed, causing damage to the blade edge. Please be careful not to perform a full cut.
- If the blade edge is damaged, it may not be possible to perform a half cut on the heat shrink tube.

# 4-3 ADJUSTING THE PRINTING PRESSURE

Adjust the printing pressure depending on the type of print material. The printing pressure setting values for each print material type are shown below.

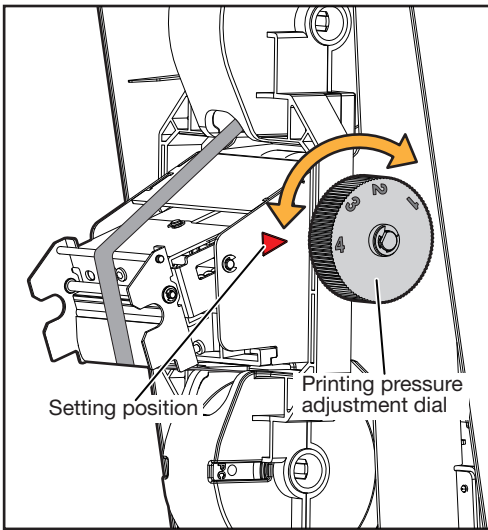

Print material	Setting value
MAX grip sleeve	2
MAX grip tube	4
MAX tube	3
Shrinkable tubes	3
Generic tubes	3
MAX ID plates	3
MAX tape	3
MAX marking plate	3
Generic marker strips	3
Block markers	3

## Adjusting the printing pressure

Before printing, adjust the printing pressure to match the print material by turning the printing pressure adjustment dial.

Print pressure: 1 = **Low**

Print pressure: 4 = **High**

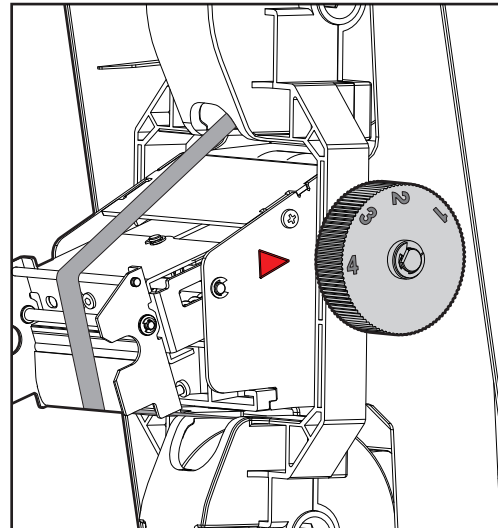
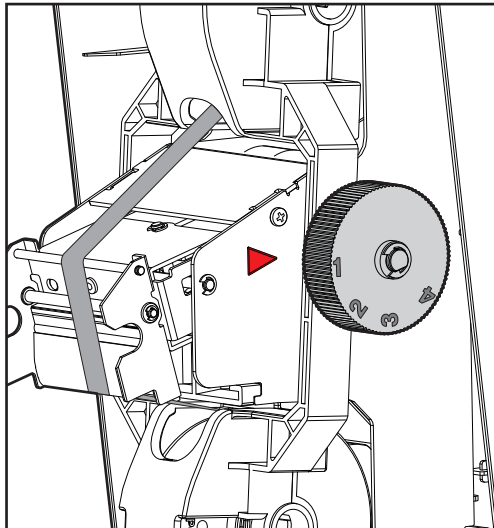

▶ : Set position

### MEMO

- If the printing appears faint or broken, try **raising** the number on the printing pressure adjustment dial by one increment.
- If the text is smudged or has thick lines, try **lowering** the number on the printing pressure adjustment dial by one increment.
- If the print material becomes dirty or has vertical streaks, try **lowering** the number on the printing pressure adjustment dial by one increment.

# 4-4 LOADING GRIP SLEEVES

## Required items:

- Grip sleeve platen roller



**1** Open the door cover on the main unit and set the printing pressure adjustment dial to "2."

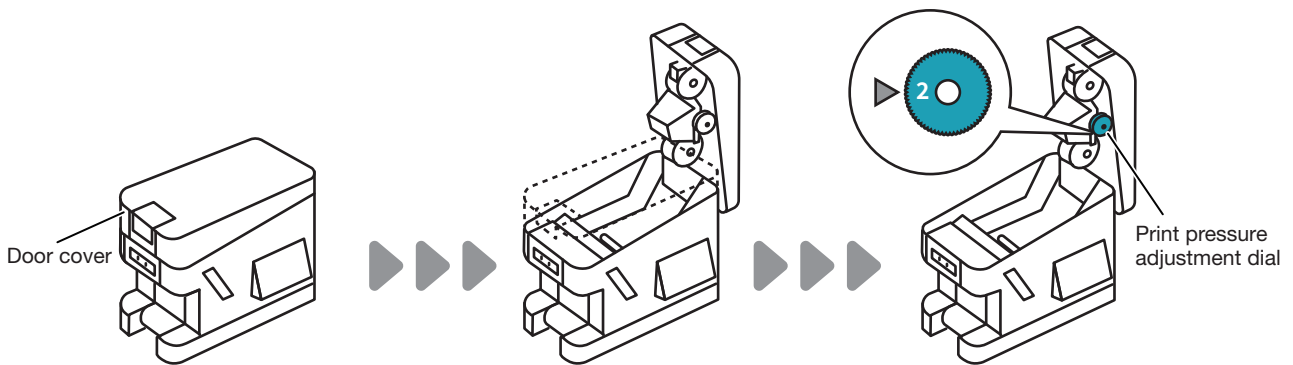

**2** Remove the platen roller and replace it with the grip sleeve platen roller.

When operating the M roller release lever "E", there is a risk that the M roller may hit your hand, so please press the "E" mark with your fingertip.

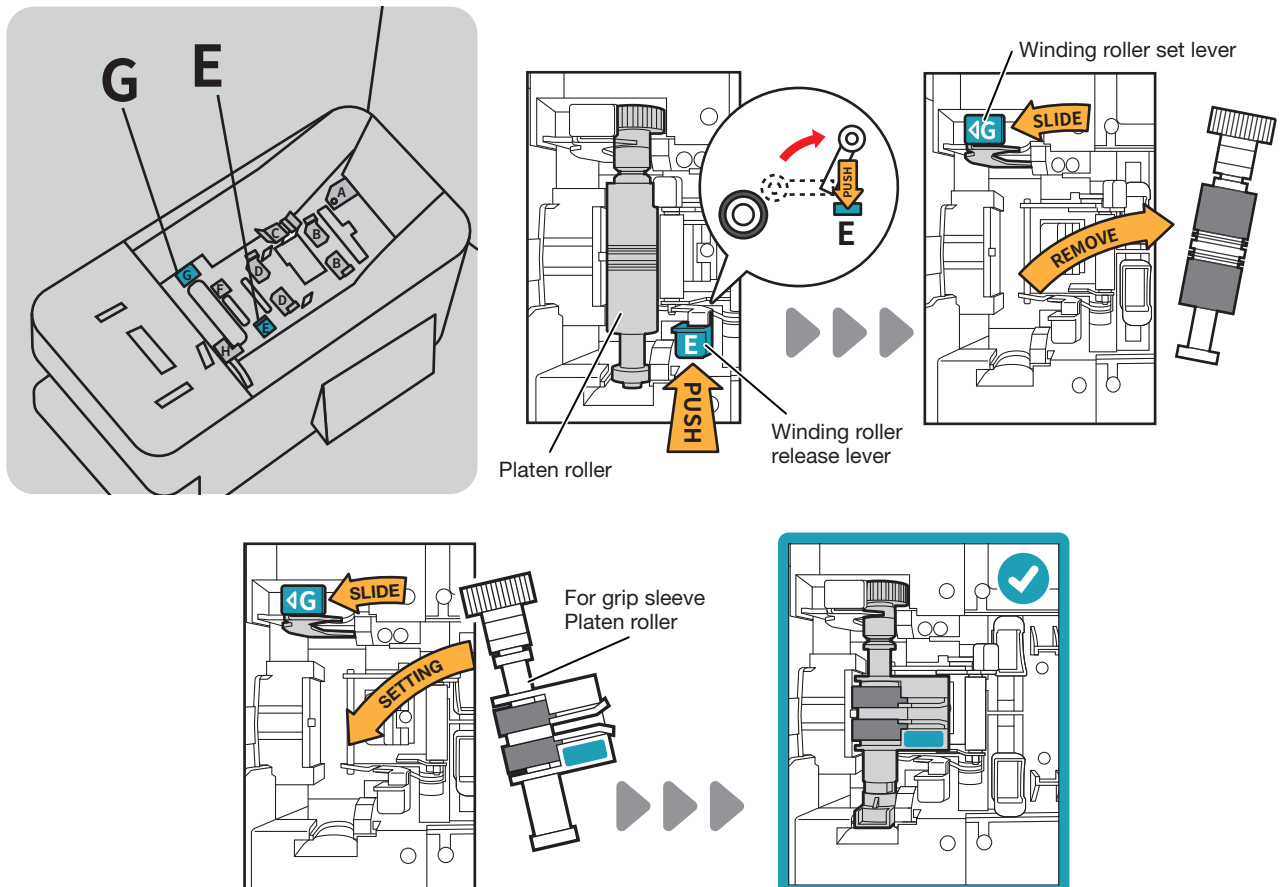

### 3 Set the media guide and operation lever to the initial position.

Check that the length measurement sensor (encoder) has been lowered to the storage position.

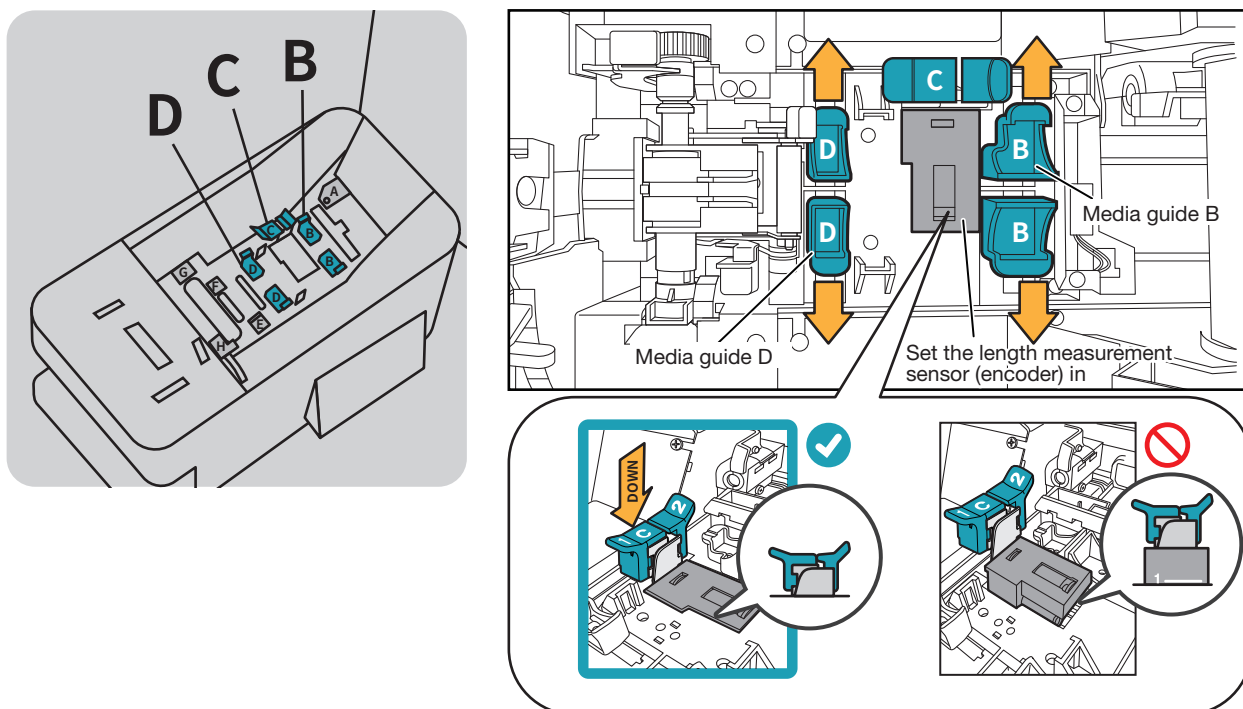

### 4 Remove any twists and set the grip sleeve in position, with the print surface facing up.

Feed the end of the grip sleeve through to the position shown in the diagram below, then adjust the width of the media guides B and D to precisely fit the width of the grip sleeve. \* Set in position with a gap of about 30cm between the main unit and the sleeve box.

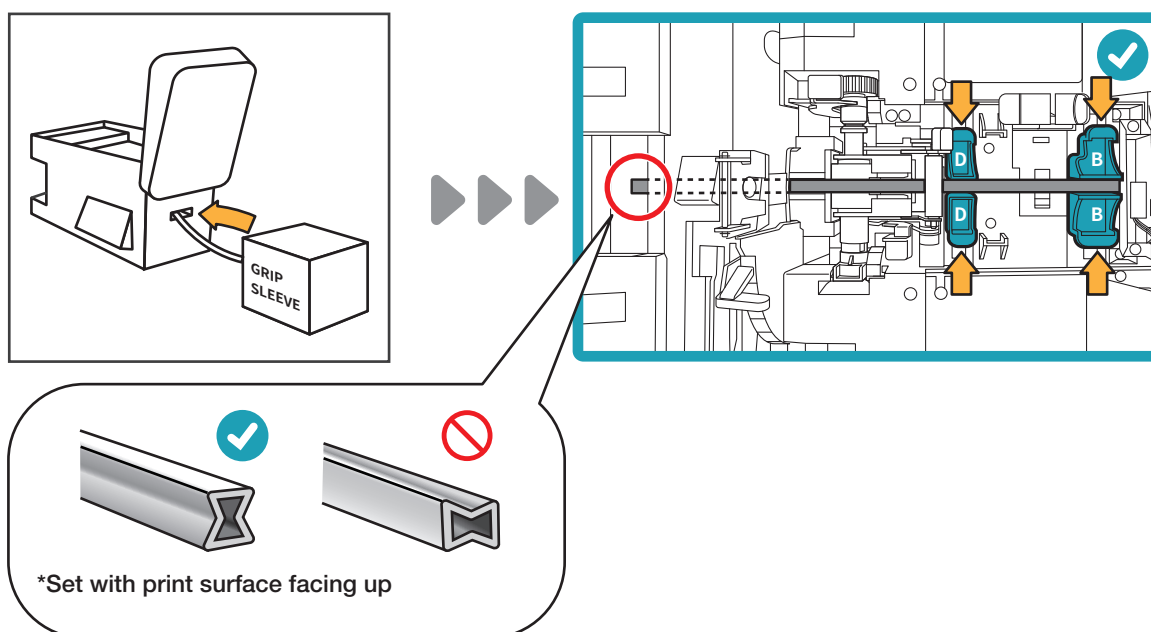

### 5 Close the door cover on the main unit. Grip sleeve loading is now complete.

#### MEMO

- To prevent the risk of the print material outlet becoming clogged or the half cutter angle becoming misaligned, when printing on materials other than thick shrinkable tubes between  $\phi 12.0$  and  $\phi 19.0$ , load the "NARROW" exit guide before printing.

# 4-5 LOADING TUBES AND ID PLATES

## Required items:

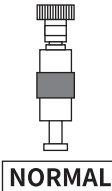
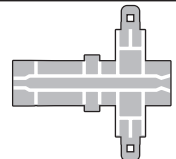
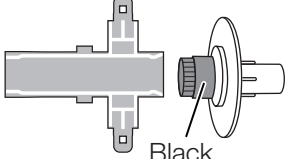
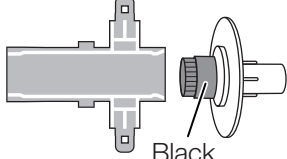
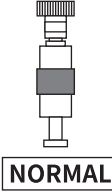
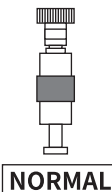
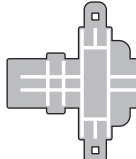
Tubes	Platen roller	Attachment	
		ø1.5 to ø2.0 tubes	ø2.5 to ø6.5 tubes
Tubes/Generic tubes	 <b>NORMAL</b>		—
		 Black	 Black
Grip tubes/ Shrinkable tubes	 <b>NORMAL</b>	—	
ID plates	 <b>NORMAL</b>		

- 1 Open the door cover on the main unit and set the printing pressure adjustment dial based on the tube type, as shown below.

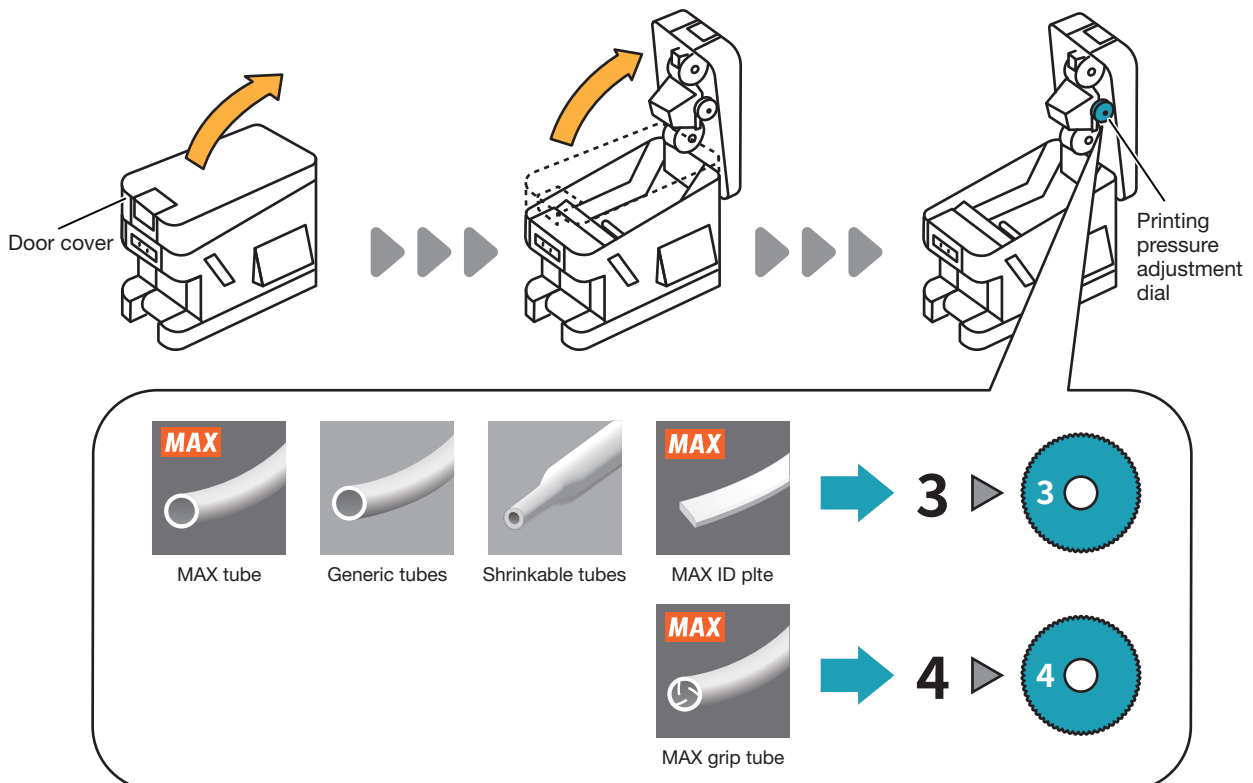

## 2 Remove the platen roller and replace it with the NORMAL platen roller.

When operating the M roller release lever "E", there is a risk that the M roller may hit your hand, so please press the "E" mark with your fingertip.

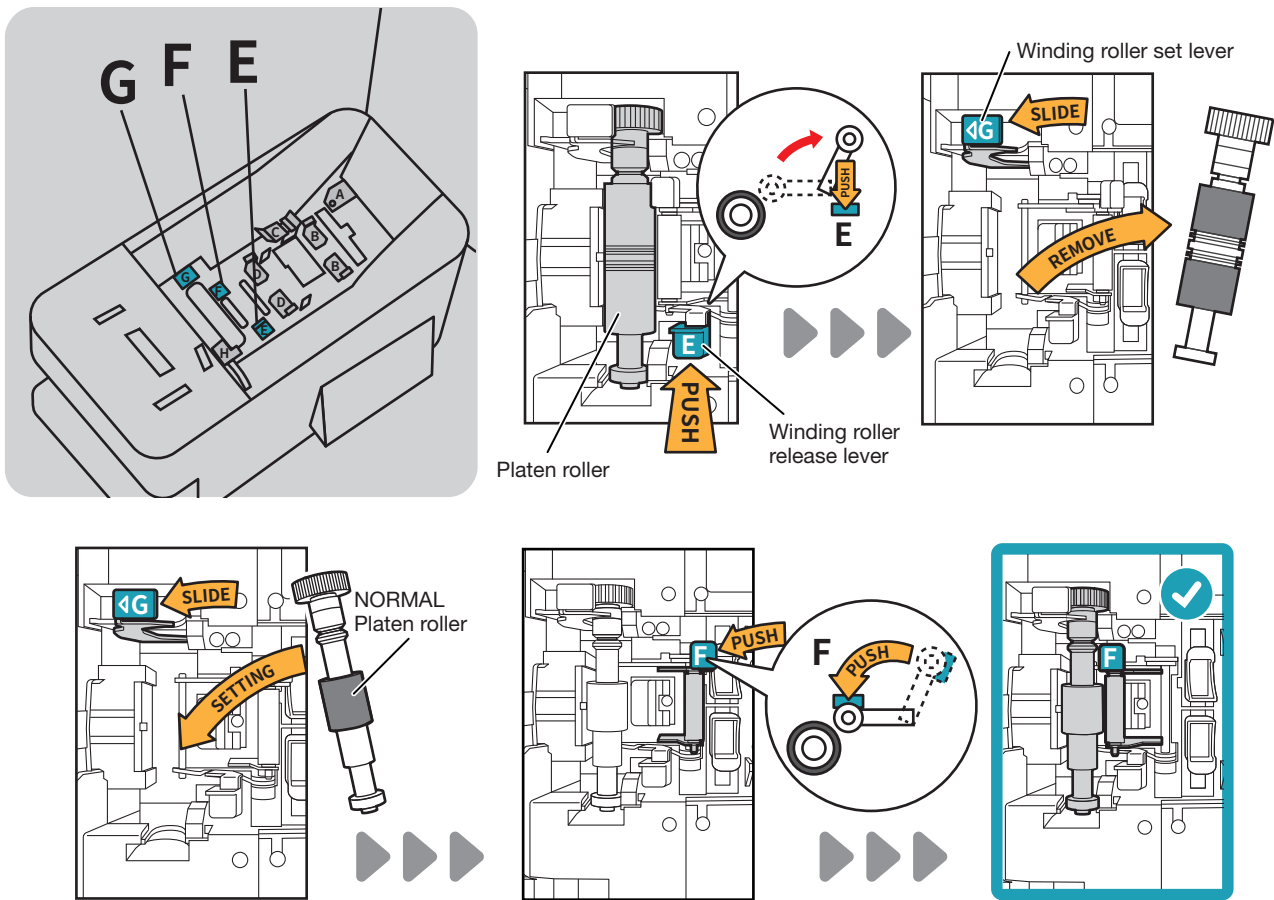

## 3 Set the media guide and operation lever to the initial position.

Check that the length measurement sensor (encoder) has been lowered to the storage position.

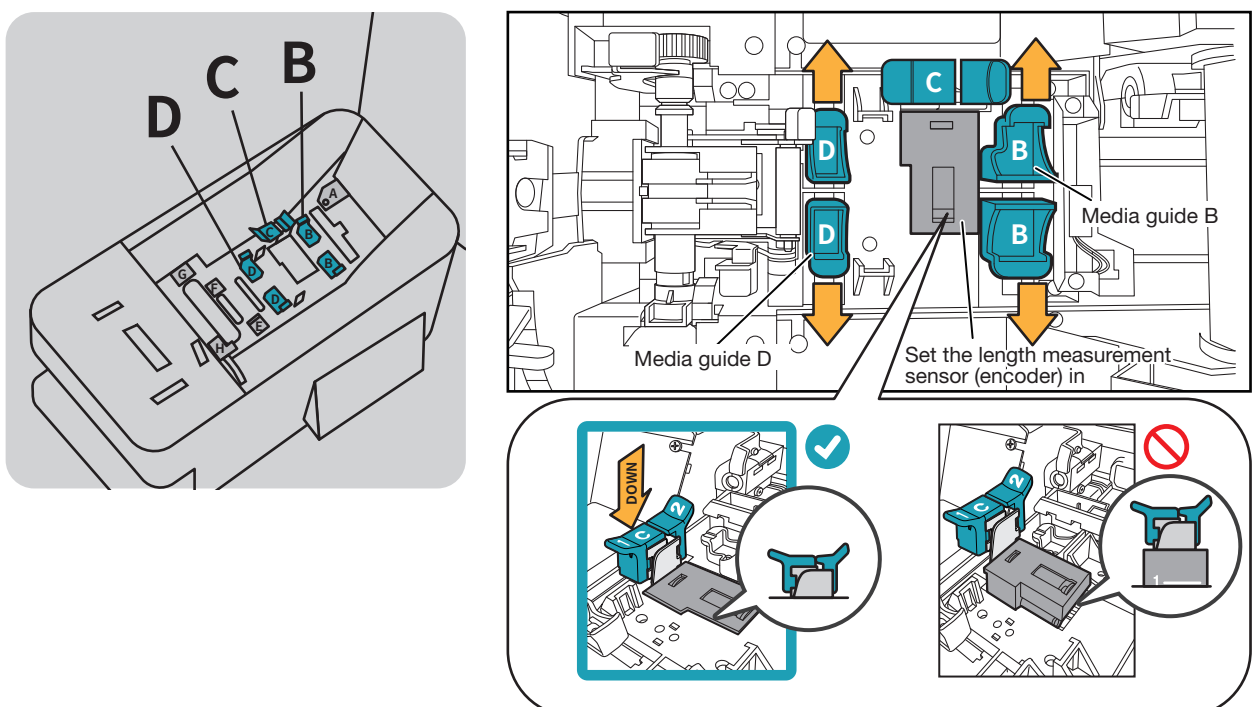

## 4-5-1 SETTING THE TUBE HEATER IN POSITION



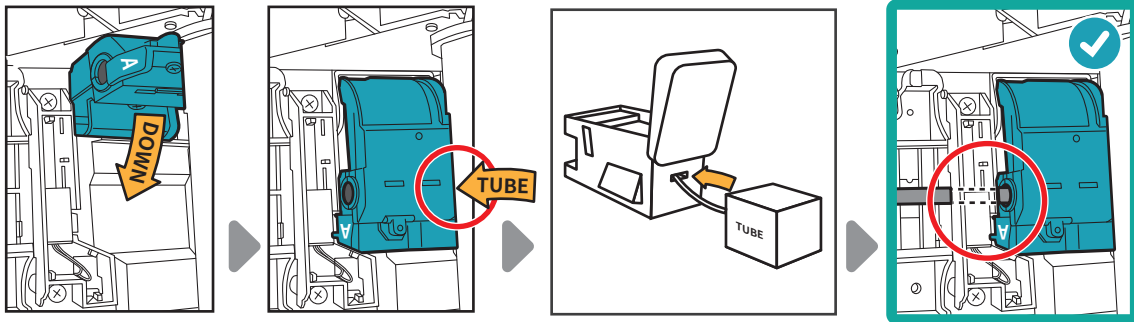
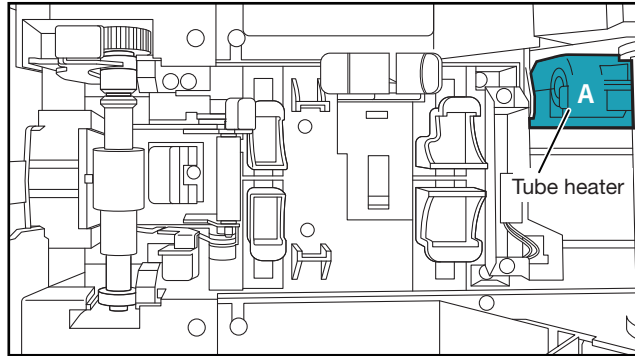
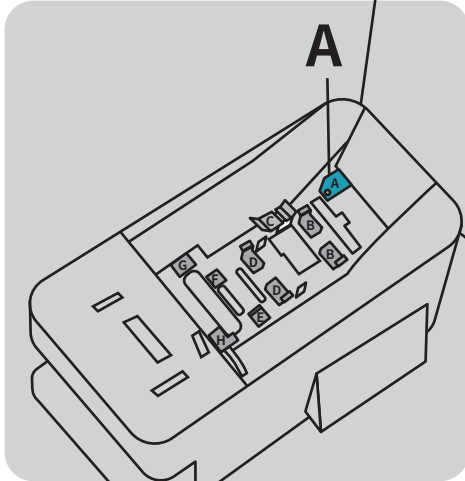

\*Only tubes that are  $\varnothing 1.5$  to  $\varnothing 6.4$  can be used.  
Use in a low temperature environment of 5 to 15°C.

Swing the tube heater A down, then pass the tube through A to set it in position.  
The tube heater can be turned on and off using the LCD display on the main unit.

→ 6-5 SWITCHING THE HEATER ON AND OFF

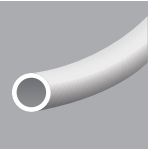

Check the type and size of tube being used, then refer to the appropriate pages.

Tubes	Size	Reference
 <p>MAX grip tube</p>	<p>ø1.5 to ø2.0</p>	<p>→ 4-5-3 MOUNTING ATTACHMENTS FOR USE WITH THIN TUBES AND THICK TUBES</p>
 <p>MAX tube</p>	<p>ø2.5 to ø6.5</p>	<p>→ 4-5-2 LOADING MAX GRIP TUBES, MAX TUBES AND GENERIC</p>
 <p>Generic tubes</p>	<p>ø8.0 to ø10.0</p>	<p>→ 4-5-3 MOUNTING ATTACHMENTS FOR USE WITH THIN TUBES AND THICK TUBES</p>
 <p>Shrinkable tubes</p>	<p>ø2.0 to ø11.5</p>	<p>→ 4-5-2 LOADING MAX GRIP TUBES, MAX TUBES AND GENERIC</p>
	<p>ø12.0 to ø19.0</p>	<p>→ 4-5-2 LOADING MAX GRIP TUBES, MAX TUBES AND GENERIC → 4-6 CHANGING THE EXIT GUIDE</p>
 <p>MAX ID plate</p>	<p>4.1mm</p>	<p>→ 4-5-3 MOUNTING ATTACHMENTS FOR USE WITH THIN TUBES AND THICK TUBES</p>

## 4-5-2 LOADING MAX GRIP TUBES, MAX TUBES AND GENERIC

When operating the M roller release lever "E", there is a risk that the M roller may hit your hand, so please press the "E" mark with your fingertip.

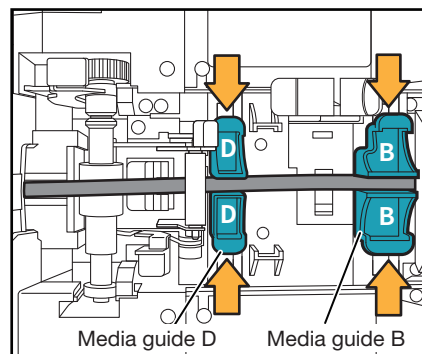
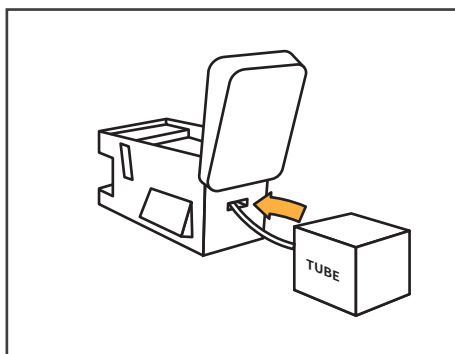
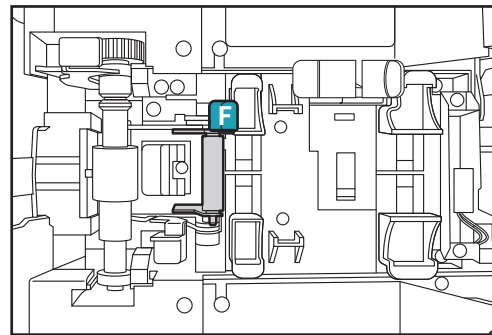
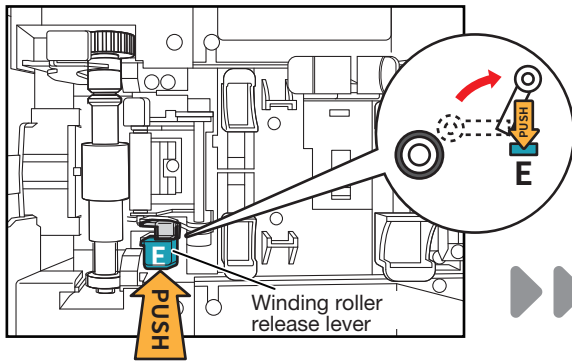

Feed the tube through and adjust the width of operation levers B and D to precisely fit the tube width.

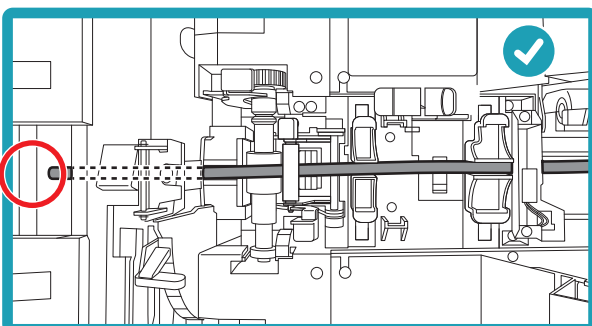
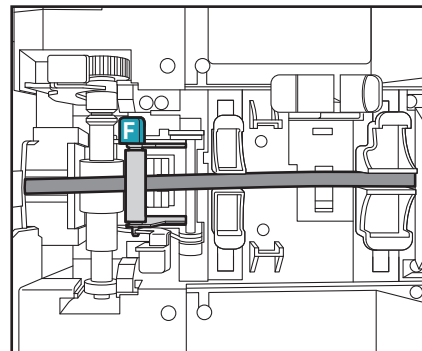
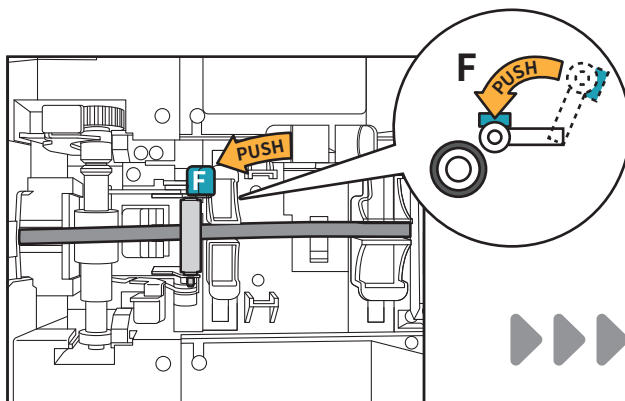

Check that the end of the tube has reached the position shown in the diagram below.

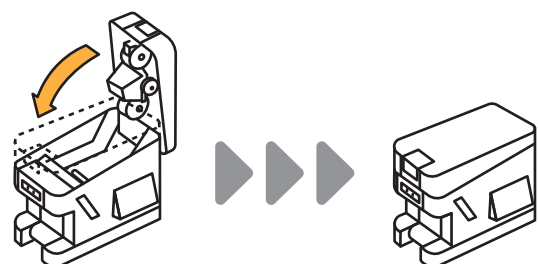

Close the door cover on the main unit.

### 4-5-3 MOUNTING ATTACHMENTS FOR USE WITH THIN TUBES AND THICK TUBES

When using  $\phi 1.5$ ,  $\phi 2.0$ ,  $\phi 8.0$  or  $\phi 10.0$  PVC tubes, mount the appropriate attachment for the tube size.

When operating the M roller release lever "E", there is a risk that the M roller may hit your hand, so please press the "E" mark with your fingertip.

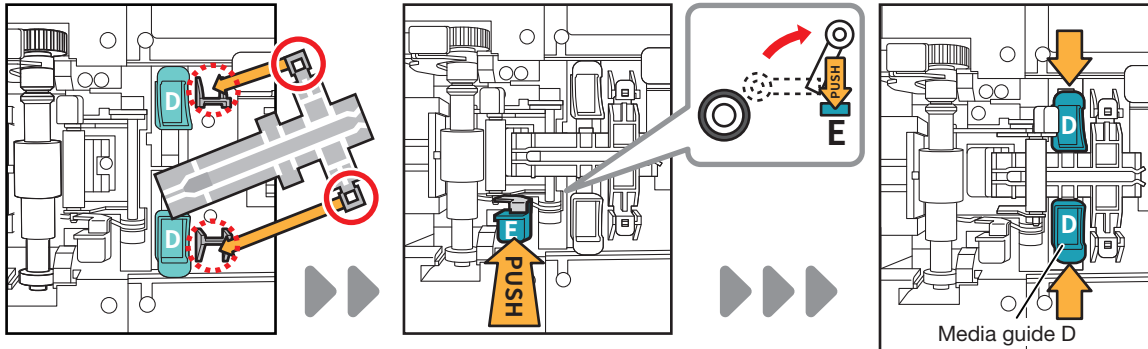

Media guide D  
Adjust the width of operation lever D to precisely fit the attachment width.

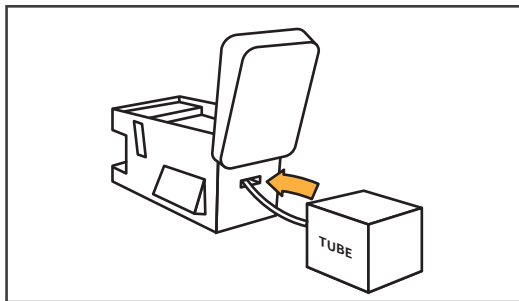

To prevent the risk of tubes becoming tangled and causing clogging, when using thin tubes of  $\phi 1.5$  or  $\phi 2.0$ , load so that the end protrudes to the position shown in the diagram below.

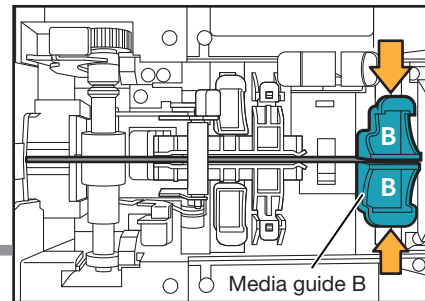

Media guide B  
Feed the tube through and adjust the width of operation lever B to precisely fit the tube width.

#### $\phi 1.5, \phi 2.0$ TUBE

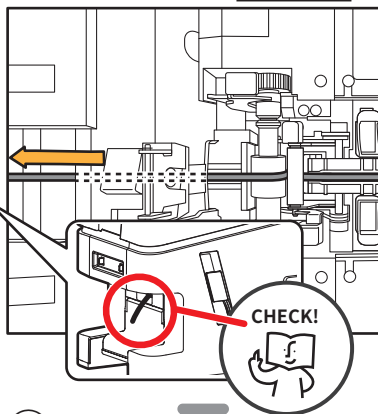

7

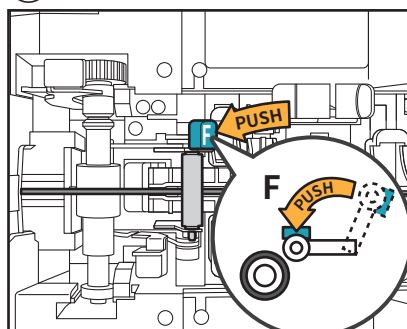

#### $\phi 8.0, \phi 10.0$ TUBE

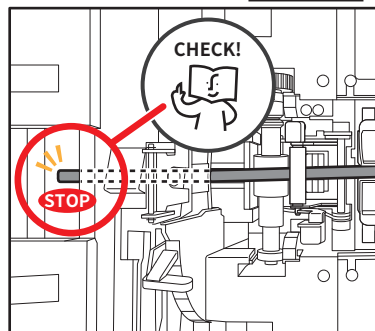

8

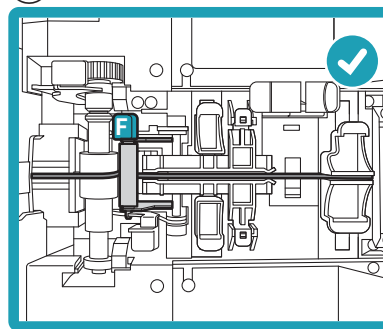

#### ID PLATE

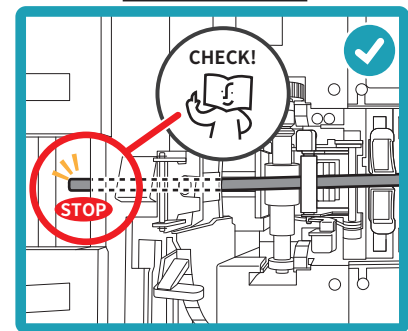

Close the door cover on the main unit.

## 4-6 CHANGING THE EXIT GUIDE

When using thick shrinkable tubes between  $\phi 12.0$  and  $\phi 19.0$ , always switch to the WIDE exit guide.

\* The exit guide is a guiding part that supports smooth print material output.

At time of purchase, the NARROW guide is installed in the main unit and the WIDE guide is stored inside the main unit.

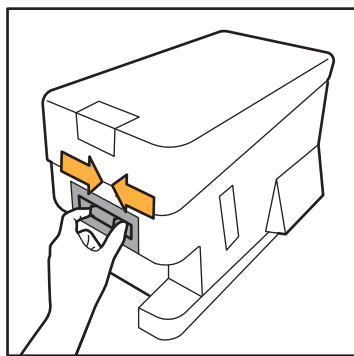
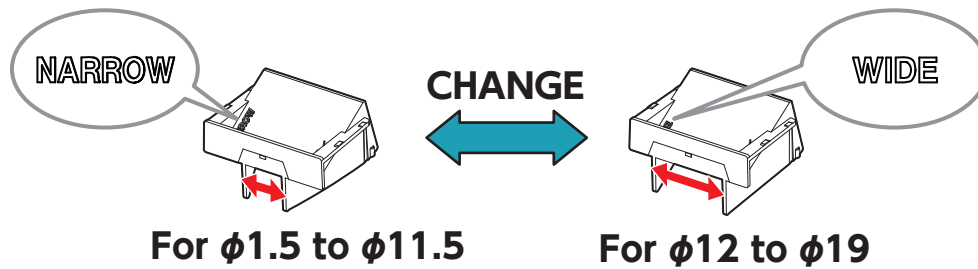

Pinch the tabs on both sides inwards to open the cover.

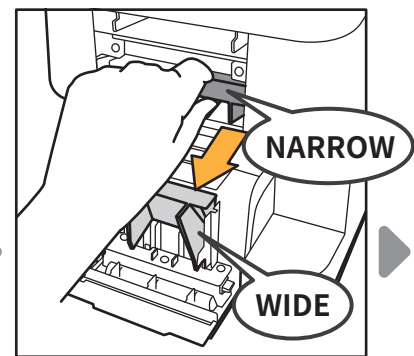
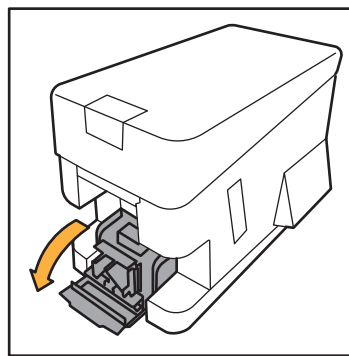

Pull the NARROW exit guide forward to remove it.

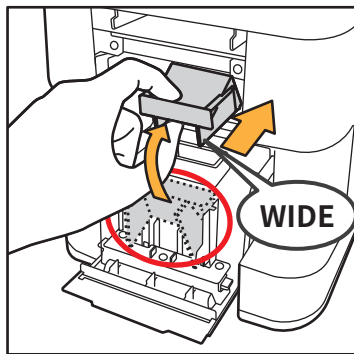

Mount the WIDE exit guide.

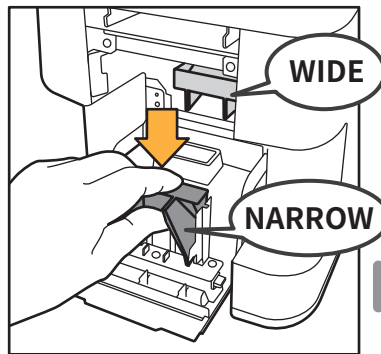

Stow the NARROW exit guide in the storage space.

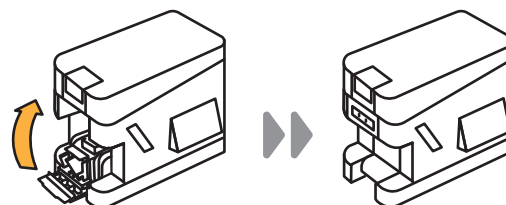
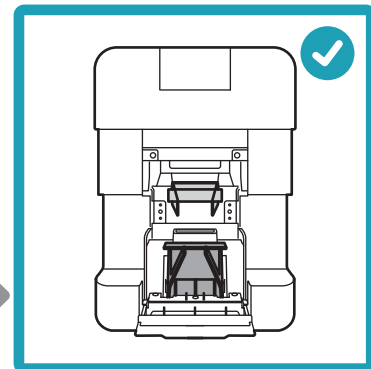

Close the main unit cover.

### MEMO

- To prevent the risk of the print material outlet becoming clogged or the half cutter angle becoming misaligned, when printing on materials other than thick shrinkable tubes between  $\phi 12.0$  and  $\phi 19.0$ , load the "NARROW" exit guide before printing.

# 4-7 LOADING TAPE AND MARKER STRIPS

## Required items:

- Platen roller (NORMAL)

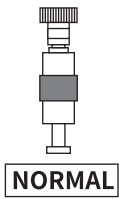

- 1 Open the door cover on the main unit and set the printing pressure adjustment dial to "3."

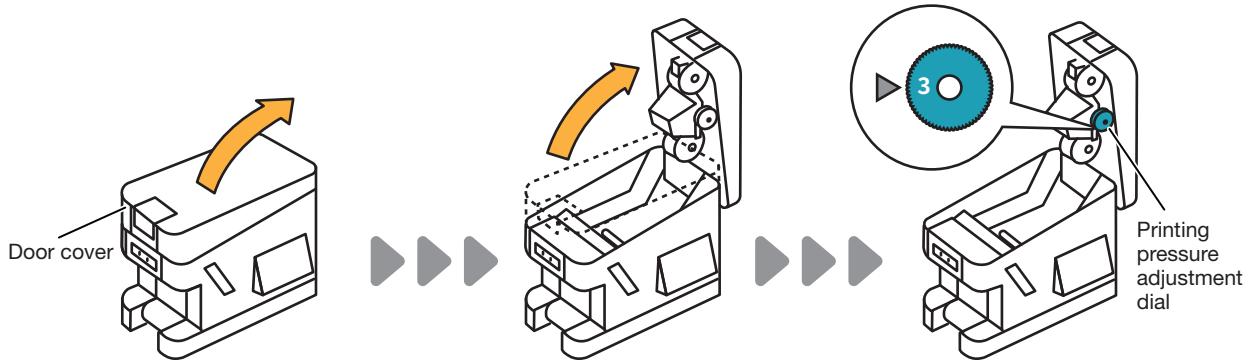

- 2 Remove the platen roller and replace it with the NORMAL platen roller.

When operating the M roller release lever "E", there is a risk that the M roller may hit your hand, so please press the "E" mark with your fingertip.

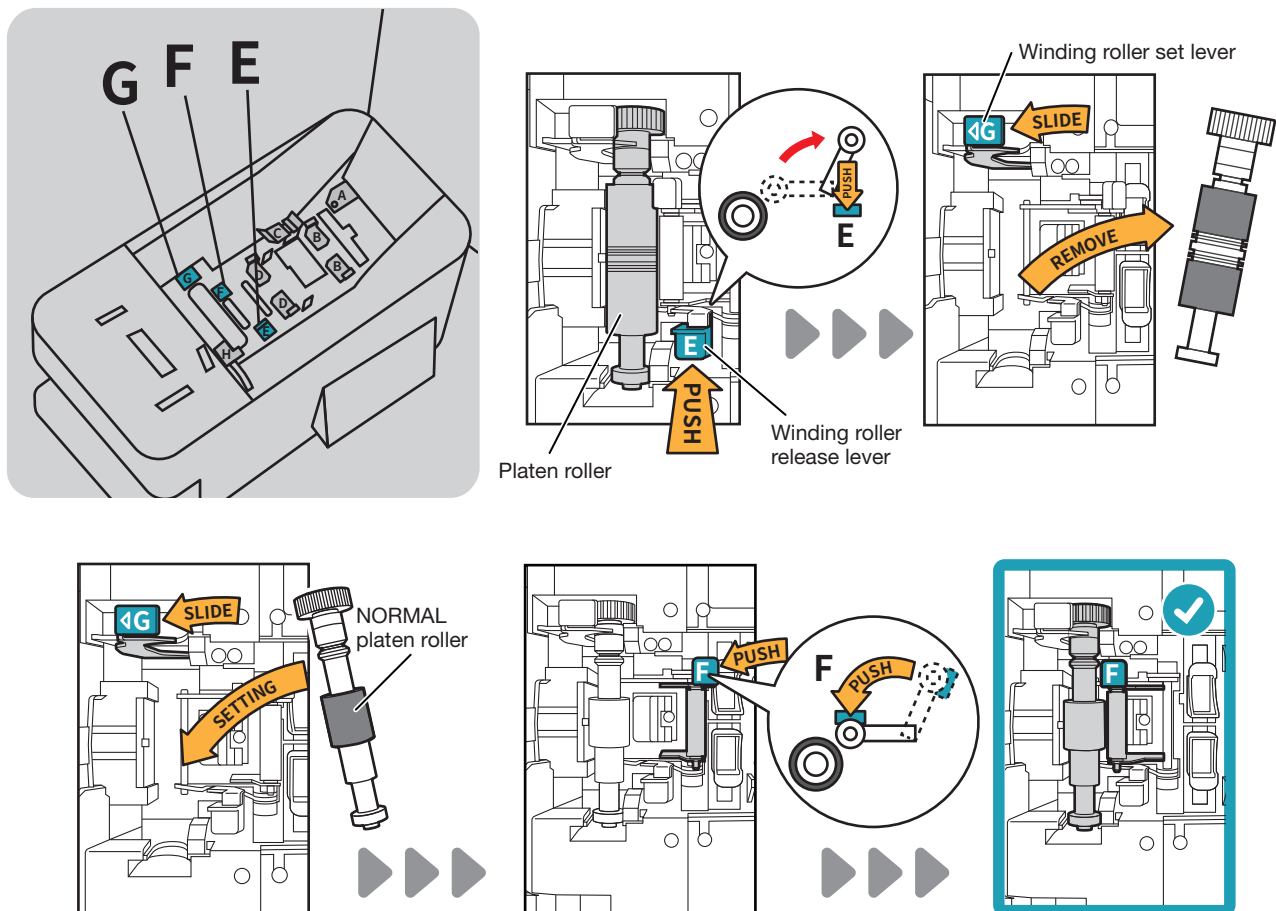

**3** Set the media guide and operation lever to the initial position.

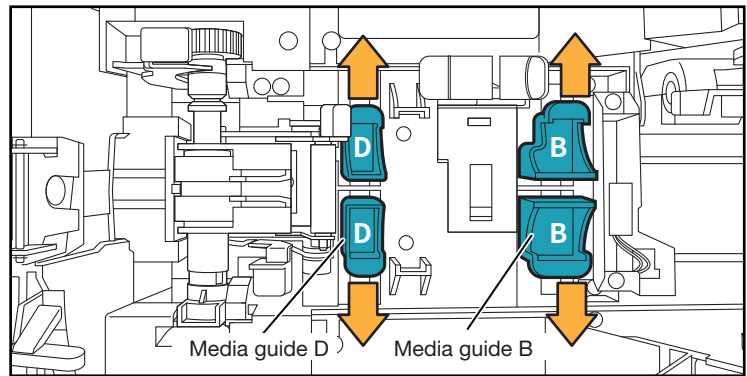
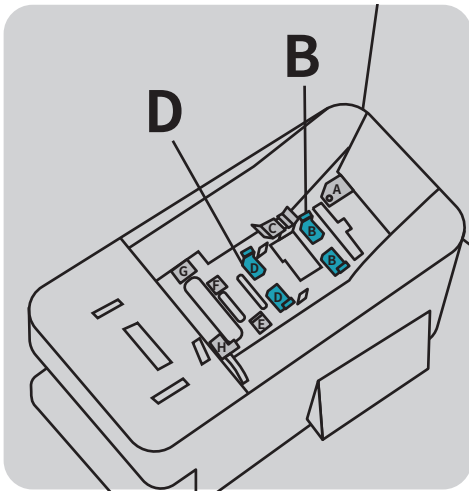

**4** Set the length measurement sensor (encoder) in position.  
 Pull the lever on the left (1C) up, then lift up the length measurement sensor (encoder).  
 Next, lift the lever on the right (2) up and place it over lever 1C.

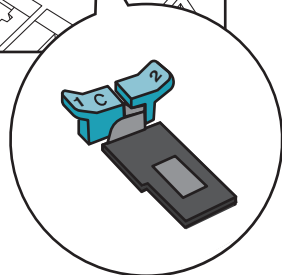
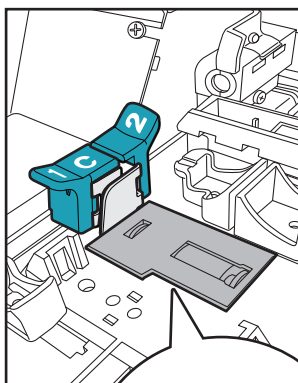
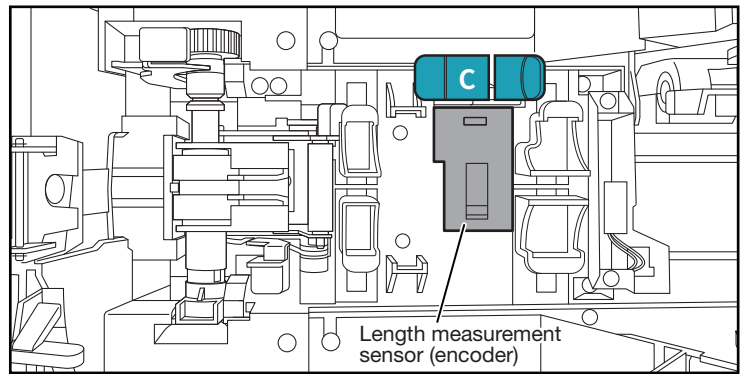
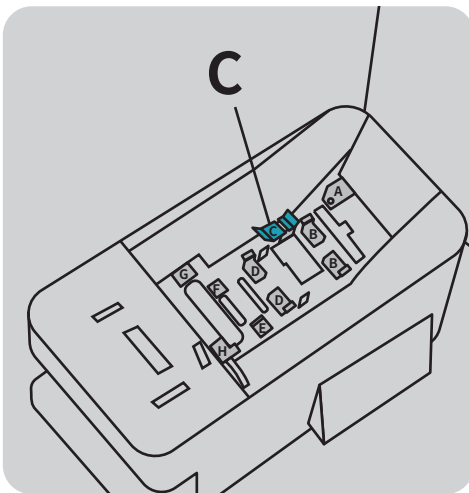

Storage position

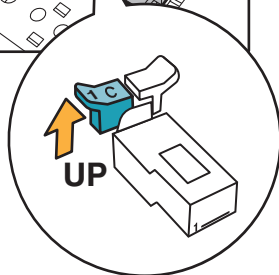
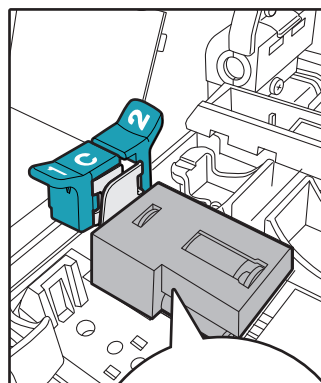

Distance measurement position  
(position during printing)

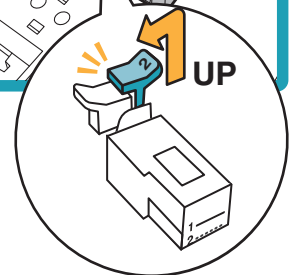
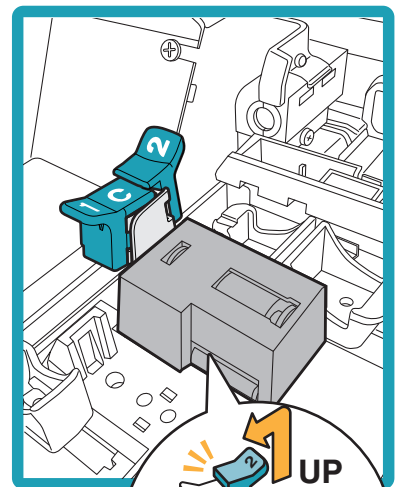

Position during print  
material loading

**MEMO**

- The length measurement sensor (encoder) position can be set to three levels.
  - Storage position
  - Distance measurement position (position during printing)
  - Position during print material loading
- The length measurement sensor (encoder) can only be used with tape and marker strips.
- Please make sure to remove the adhesive on the tape contact surfaces of Media Guides B and D by pressing the adhesive side of the tape before printing. If the adhesive is transferred and adheres to the platen roller or Length Measurement Sensor, it may cause consumable entanglement or printing defects.

→ 10-5 CLEANING MEDIA GUIDES B AND D (METHOD FOR REMOVING TAPE ADHESIVE)

**5** Load the tape or marker strip.

Pass the print material through the length measurement sensor (encoder) as shown in the diagram below. After passing the print material through, adjust the width of the media guides B and D to precisely fit the width of the print material.

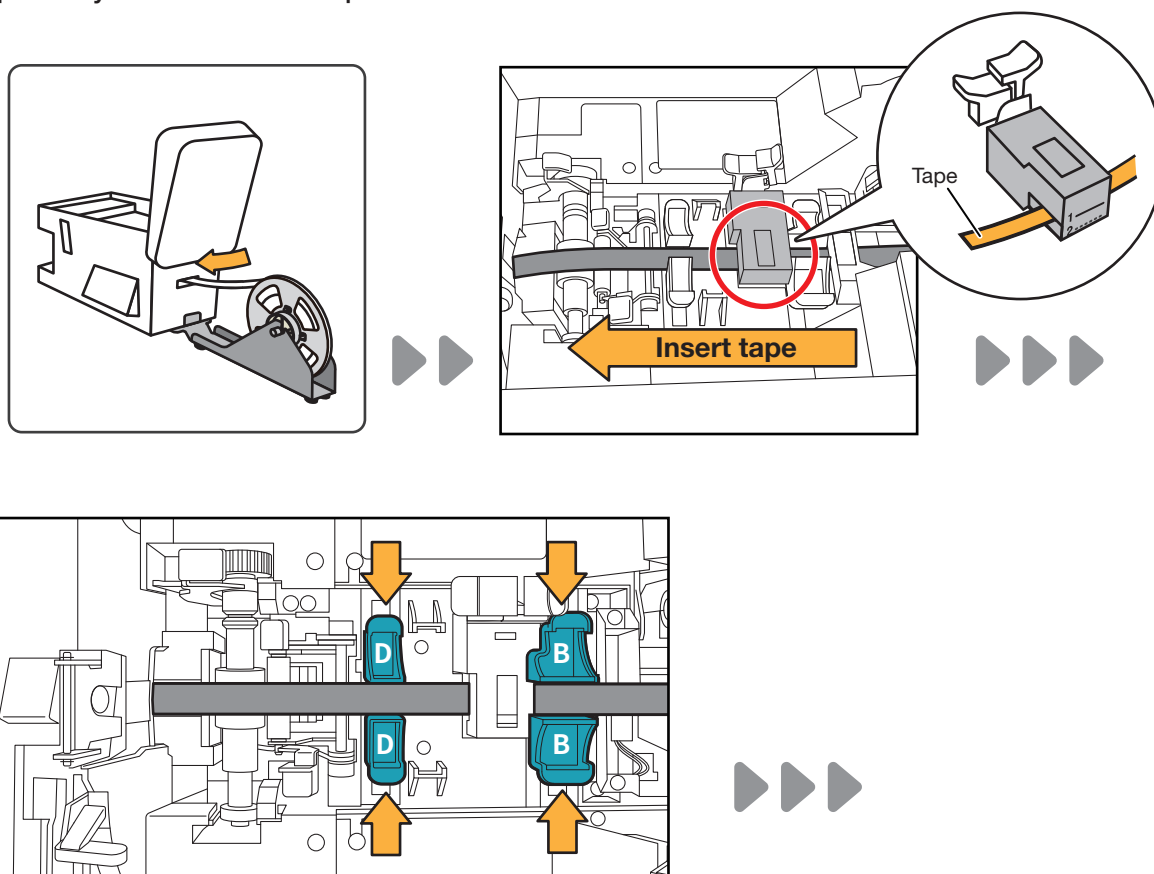

**6** Gently push operation lever 2 down and set to the distance measurement position (position during printing).

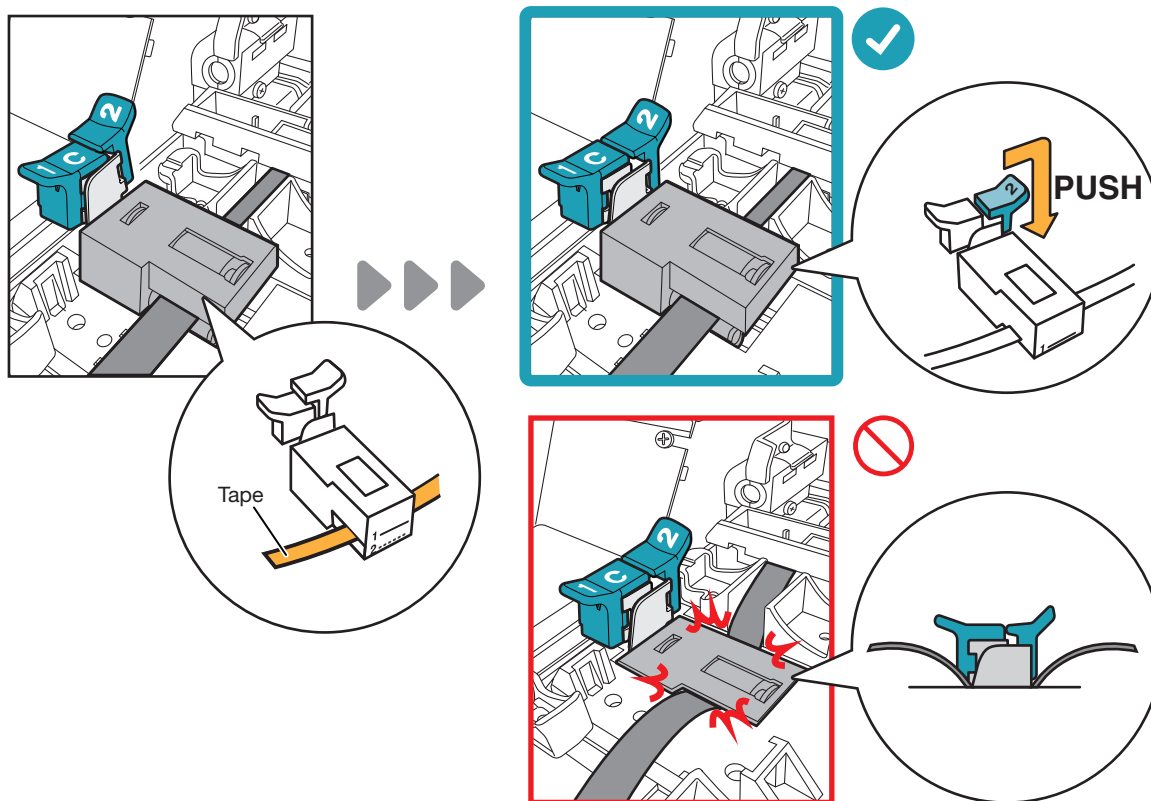

 <b>CAUTION</b>	Take care not to push the length measurement sensor (encoder) down to the storage position.
--	---

Feed the end of the print material through to the position shown in the diagram below.

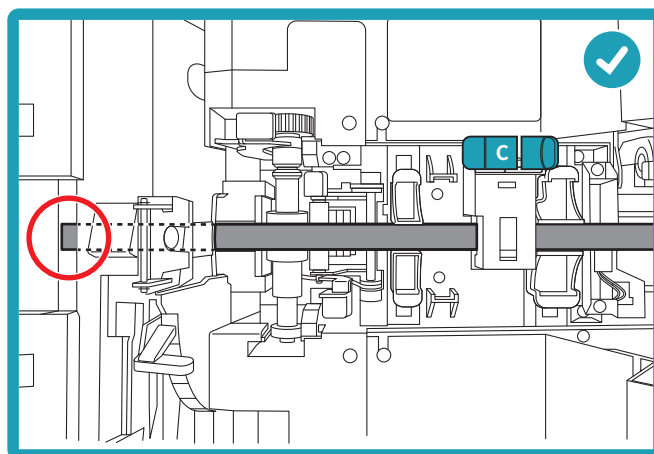

**7** Close the door cover on the main unit. Loading of the tape or marker strip is now complete.

# 4-8 LOADING BLOCK MARKERS

## Required items:

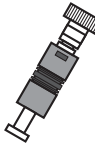
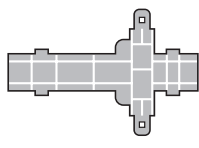
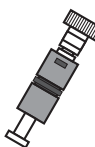
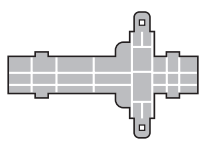
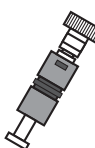
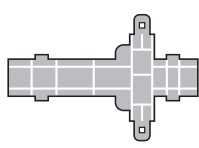
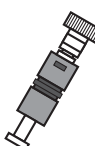
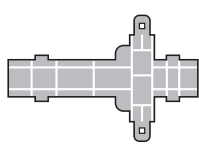
Block markers	Platen roller		Attachment	
A 2009-113 A 2009-114 A 2009-115	113 114 115		113 114 115 515 615	
A 2009-145	145		145	
A 2009-515	515		113 114 115 515 615	
A 2009-615	615		113 114 115 515 615	

- 1 Open the door cover on the main unit and set the printing pressure adjustment dial to "3."

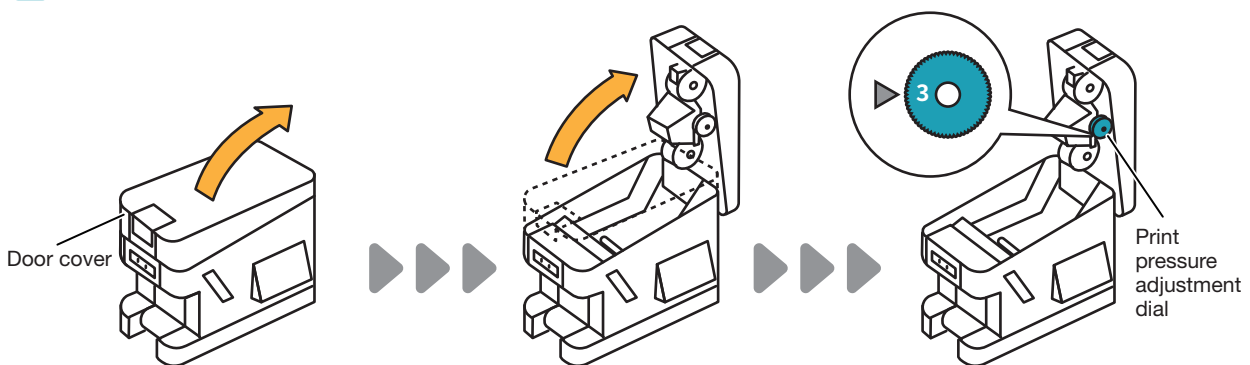

**2** Remove the platen roller and replace it with the appropriate platen roller based on the block marker type.

When operating the M roller release lever "E", there is a risk that the M roller may hit your hand, so please press the "E" mark with your fingertip.

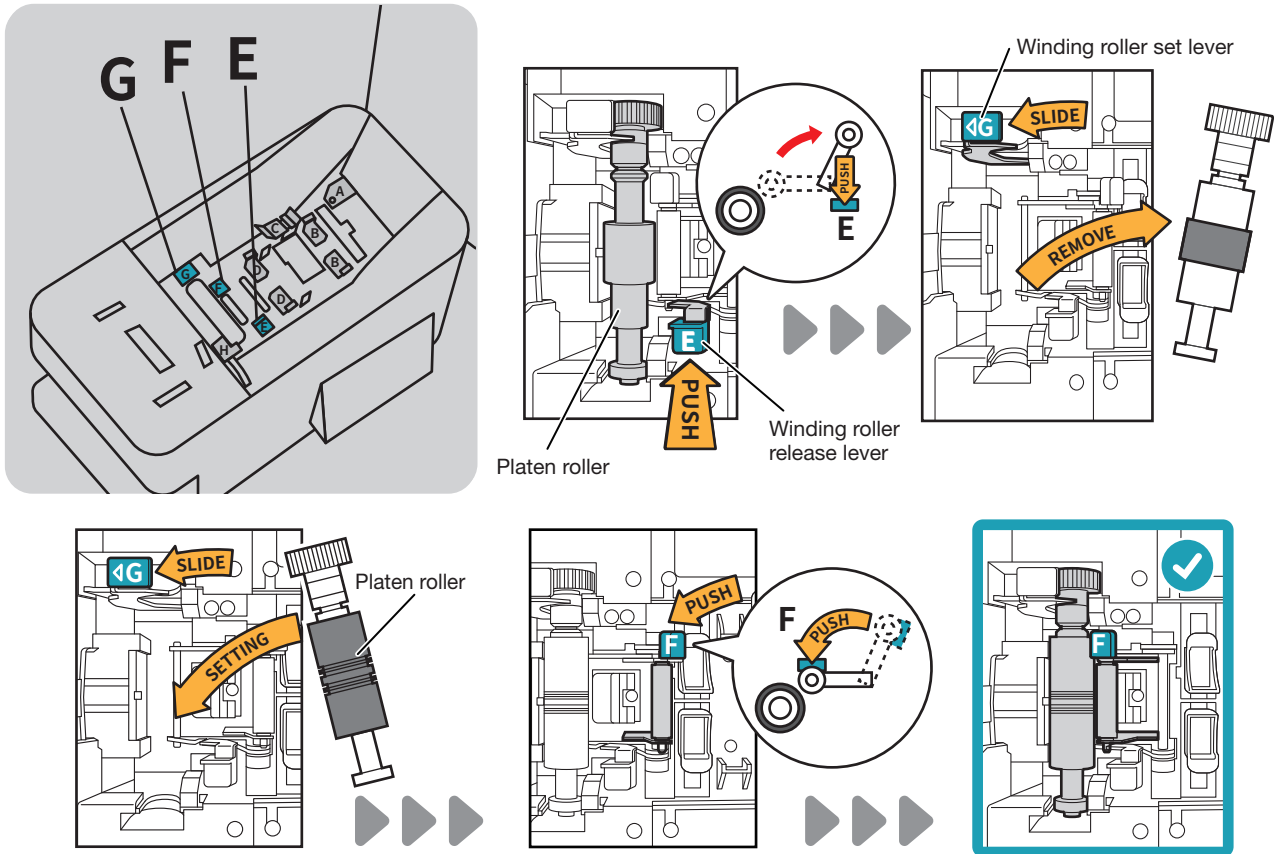

**3** Set the media guide and operation lever to the initial position.

Check that the length measurement sensor (encoder) has been lowered to the storage position.

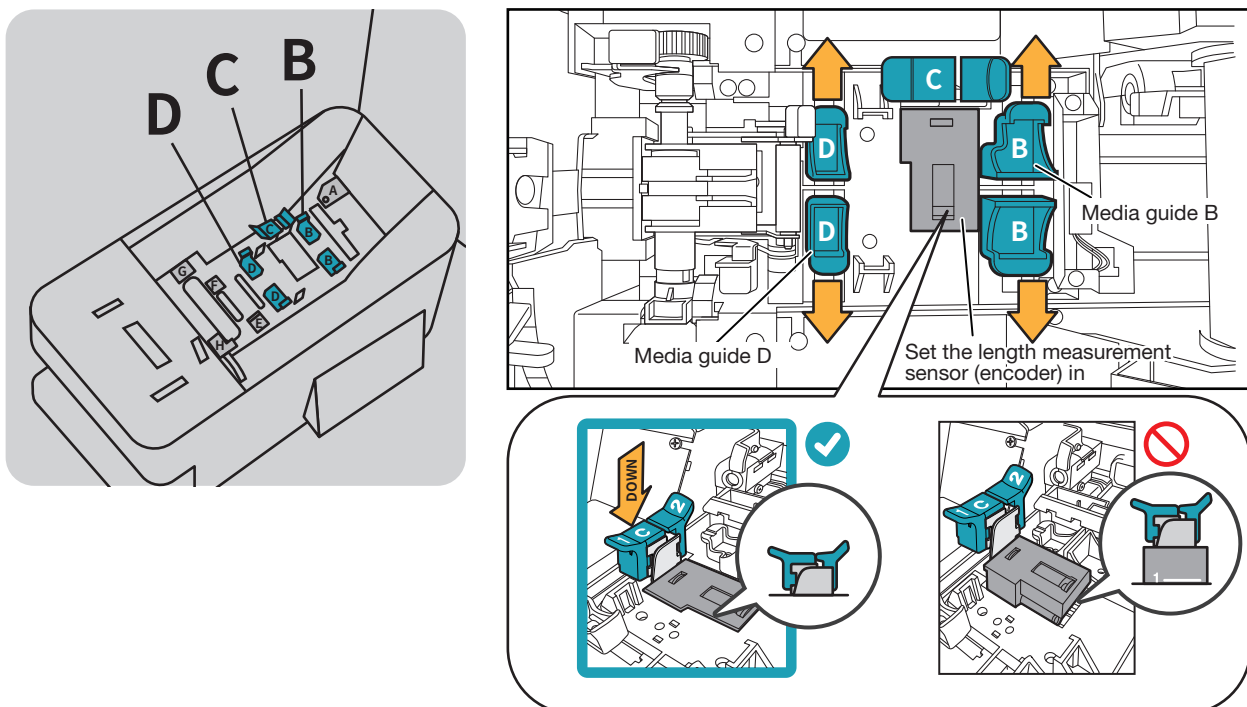

- 4** Insert the attachment while taking care to orientate it as shown in the diagram below, then adjust the width of the media guides B and D to precisely fit the width of the attachment.

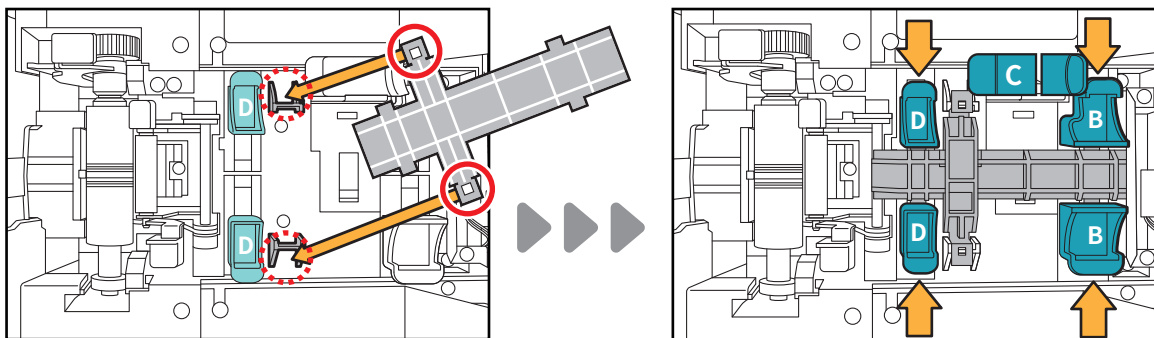

- 5** Load the block marker.

Feed the end of the block marker through to the position shown in the diagram below.

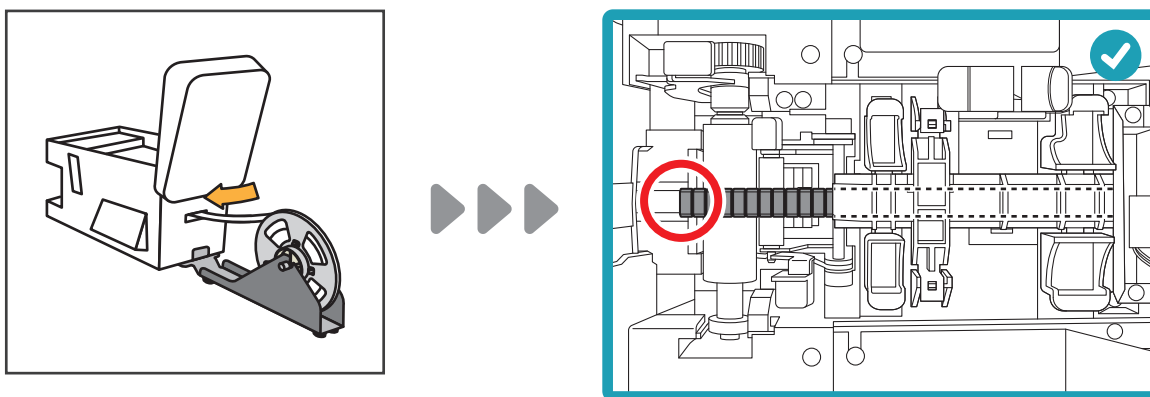

- 6** Close the door cover on the main unit. Loading of the block marker is now complete.

# 4-9 INSTALLING THE INK RIBBON

Required items:

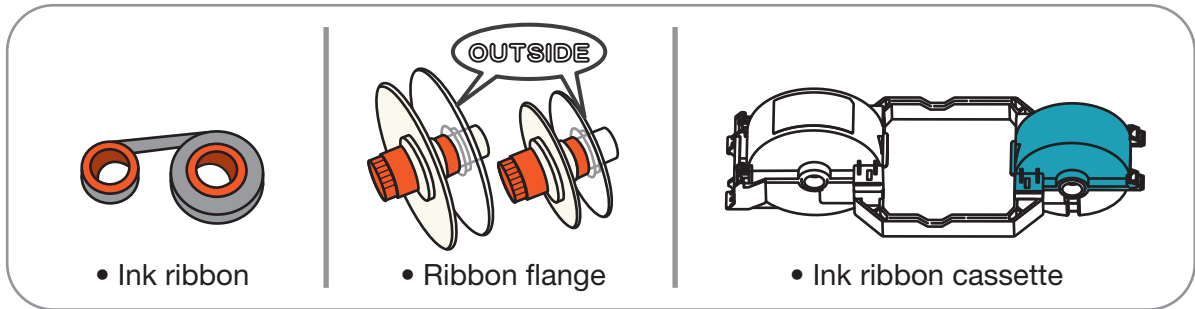

**1** Mount the ink ribbon onto the ribbon flanges. Turn the ribbon flange in the direction of **RELEASE** and remove it.

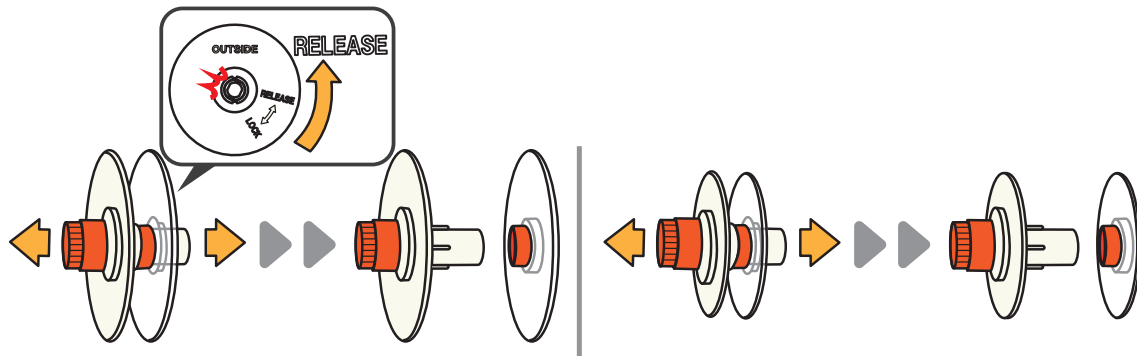

Align the concave section of the ink ribbon core with the convex section of the flanges when mounting. Turn the ribbon flange in the direction of **LOCK** and secure it.

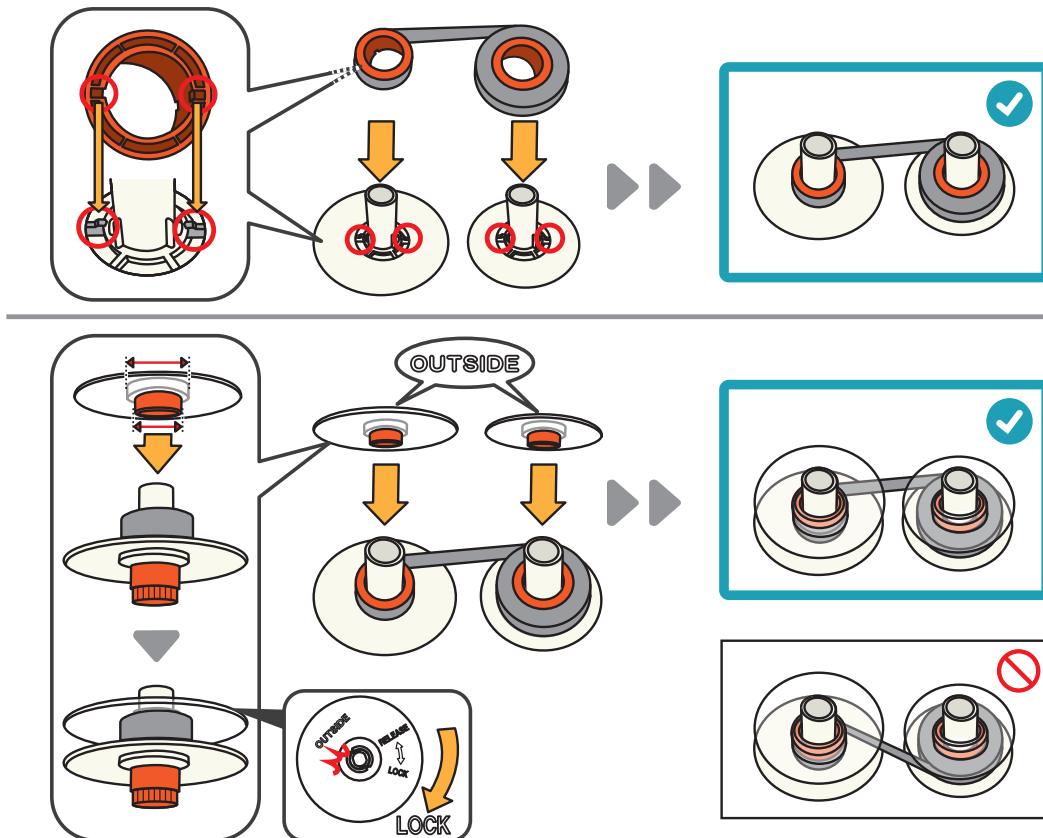

**CAUTION**

Pay attention to the size of the ribbon flanges and attach as above.

## 2 Insert the ink ribbon into the ink ribbon cassette.

Align the convex (orange) section of the ribbon flange core with the concave section of the cassette when inserting.

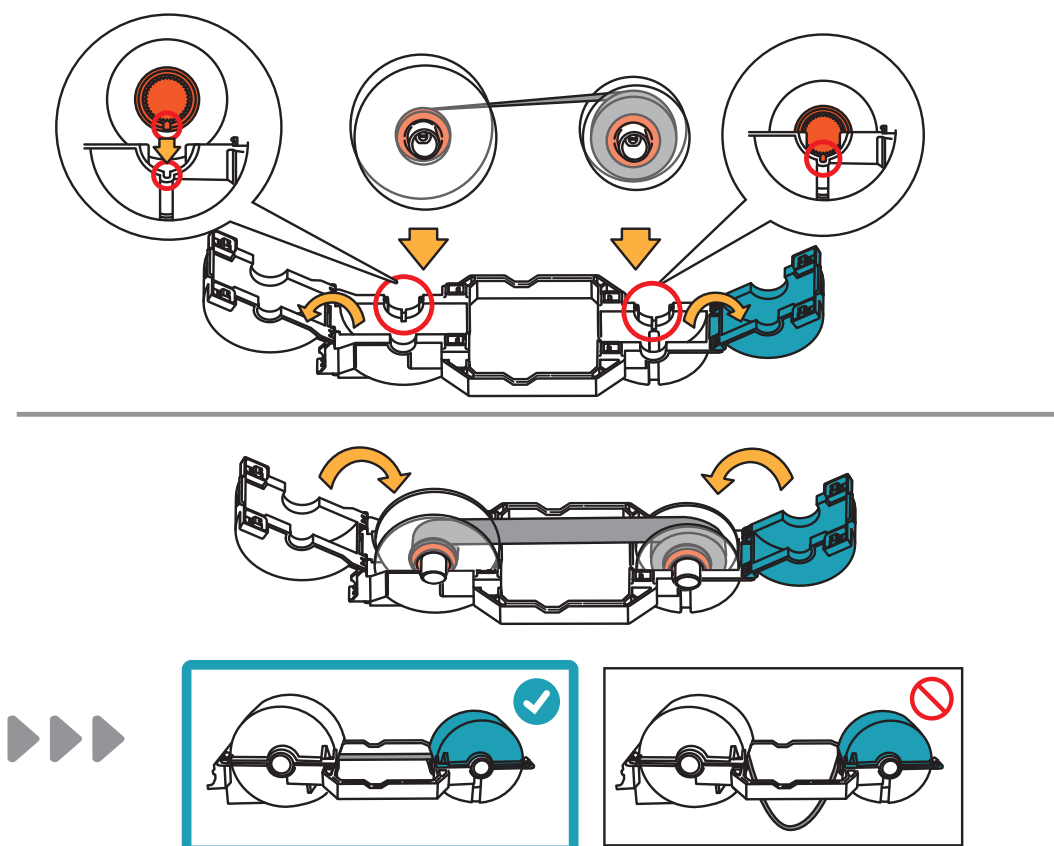

## 3 Insert the ink ribbon cassette into the main unit.

Insert so that the blue mounting position in the main unit is layered over the blue section of the ink ribbon cassette.

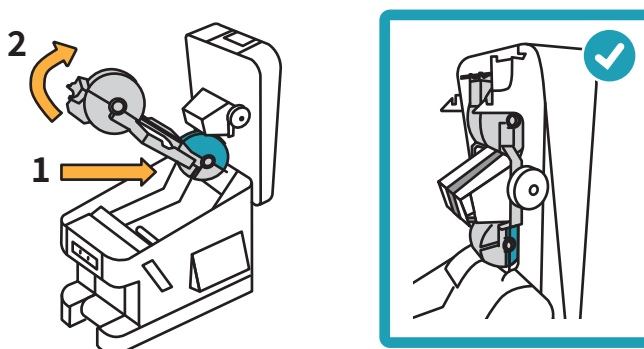

## 4 Close the door cover on the main unit. Ink ribbon installation is now complete.

# 4-10 INSTALLING THE REEL STAND

Use the reel stand with MAX tape, MAX marking plates, block markers and MAX ID plates.

## Required items:

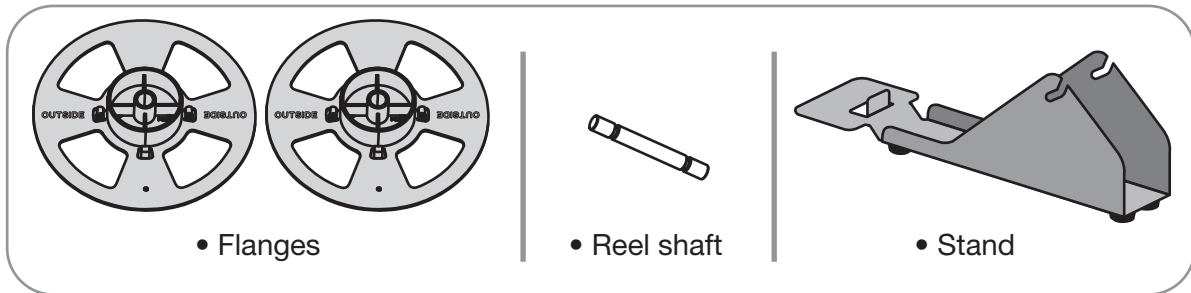

Flanges are used when the print material is MAX tape or MAX marking plates.

- 1 Load the print material. Orient the flanges so that the engravings that read **OUTSIDE** are on the outside, then set them in position.

When using MAX tape use without peeling off the unrolling prevention film on the tape side.

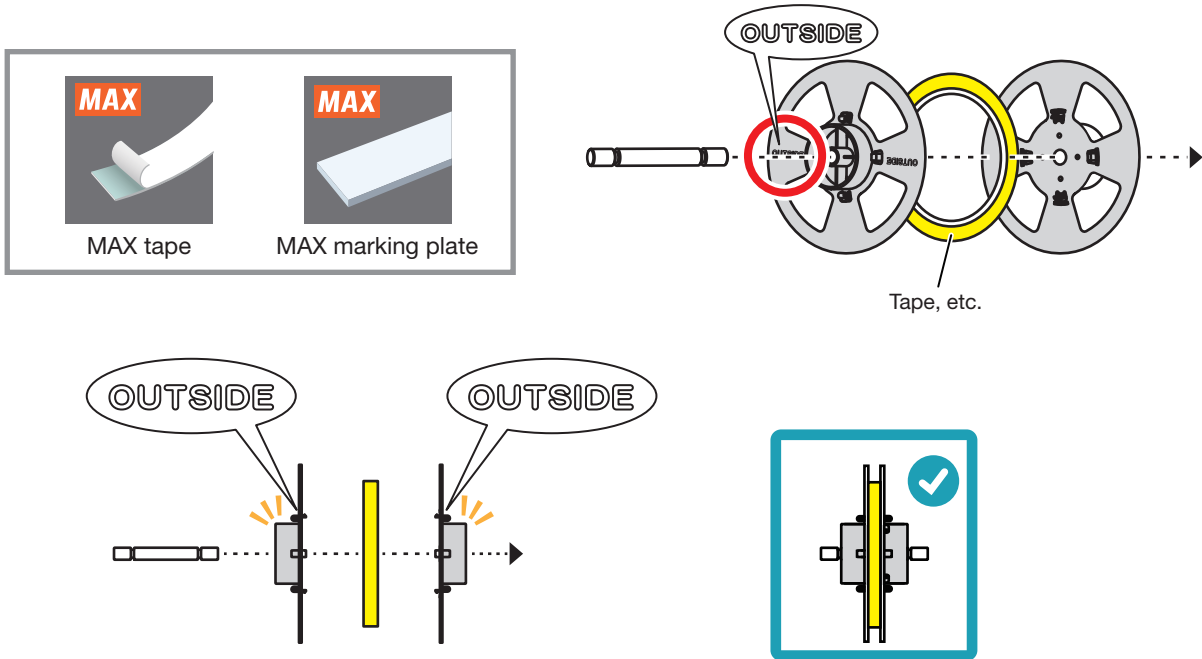

With MAX ID plates and block markers, feed directly through the reel shaft without using flanges, then set the stand in position.



### CAUTION

When loading tape with a width of 5mm onto the flanges, offset the flanges so that the flange claws do not interfere with each other.

## 2 Insert the reel into the stand.

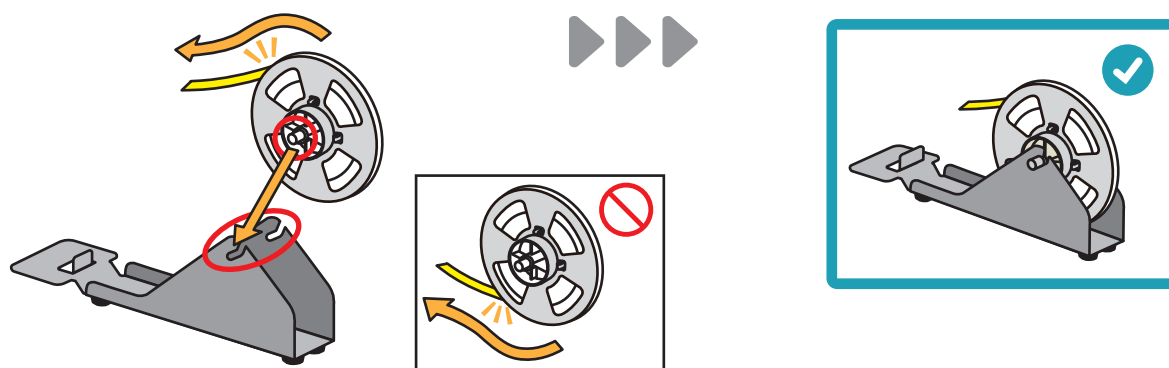

## 3 Insert the reel stand in the rear of the main unit.

Insert the end of the reel stand into the handle section of the main unit.

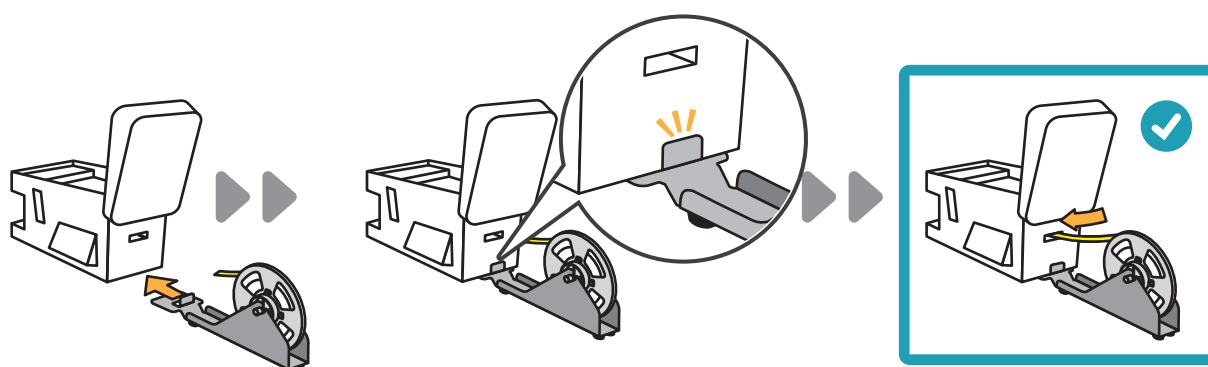

### MEMO

- If the tape comes off the paper tube, cut off one or two turns of the tape on the inside and fit it back into the paper tube.

# Chapter 5

## REPLACING CONSUMABLES

---

5-1 REPLACING THE HALF CUTTER UNIT.....	74
5-2 REPLACING THE THERMAL HEAD .....	75

# 5-1 REPLACING THE HALF CUTTER UNIT

The half cutter unit is placed in the main unit in advance. If half cutting sharpness has deteriorated, replace the half cutter as described below.

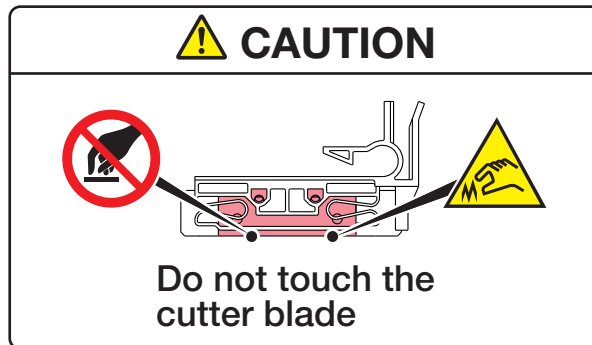

## Removal

Lift the half cutter unit by the tab and remove it by moving in the direction shown by the arrow.

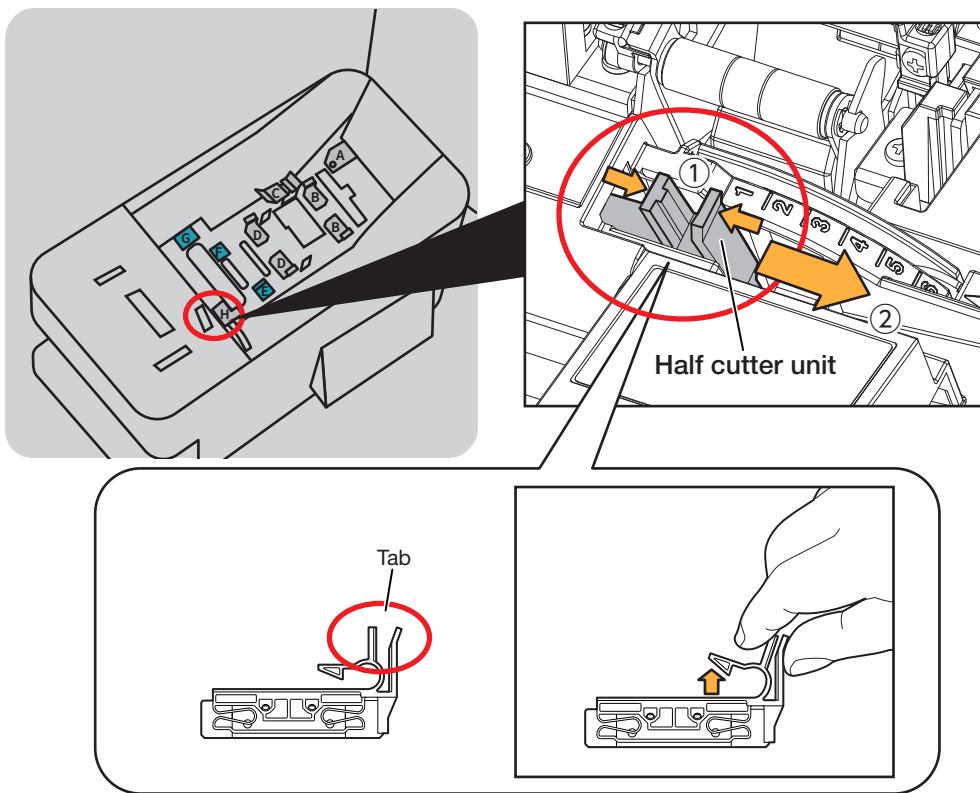

## Insertion

Align the guides on both sides of the half cutter unit with the grooves in the insertion section, then insert fully until it clicks.

Replacement is now complete.

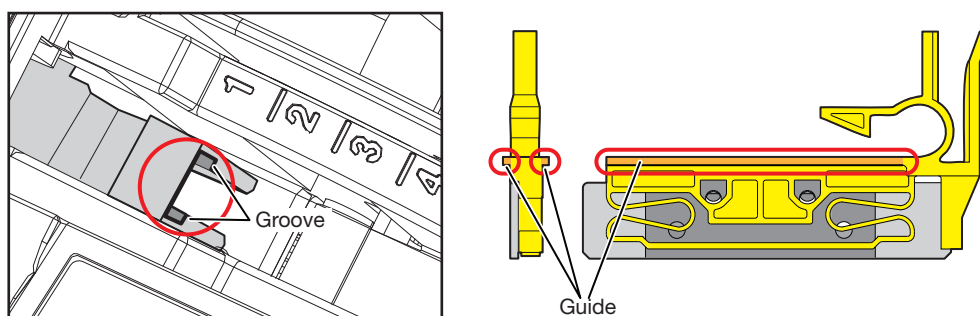

# 5-2 REPLACING THE THERMAL HEAD

## NOTE

- Do not touch the thermal head heating element with bare hands. Doing so can cause the static electricity to damage the heating element.

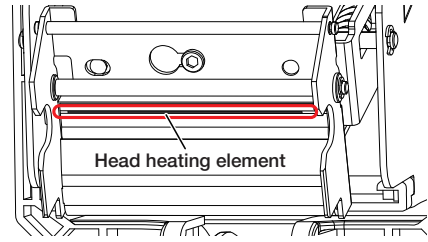

## Removing the thermal head

- 1 Set the printing pressure adjustment dial to "1."

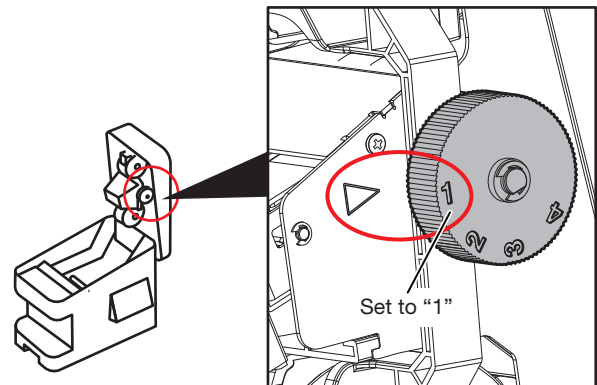

- 2 Turn the hexagon socket head bolt in the center of the thermal head counterclockwise approximately five times to loosen it.

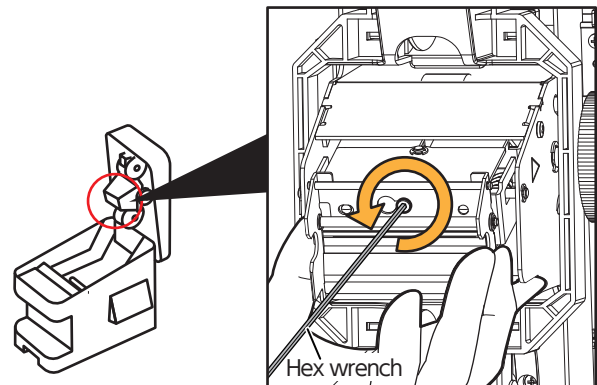

- 3 After loosening the hexagon socket head bolt, slide the thermal head to the right and remove it.

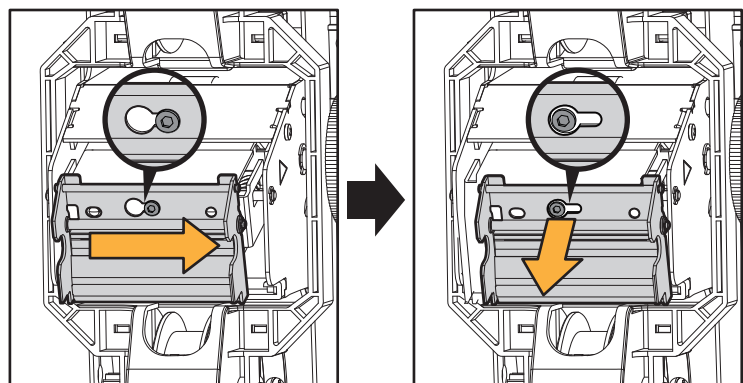

**4** Detach the connector.

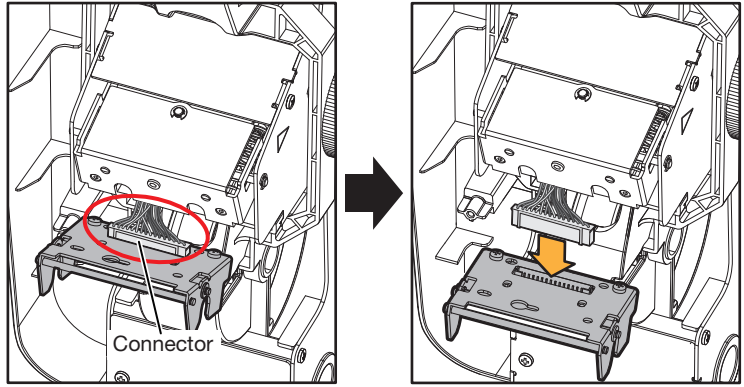

## Mounting the thermal head

- 1 Attach the connector.

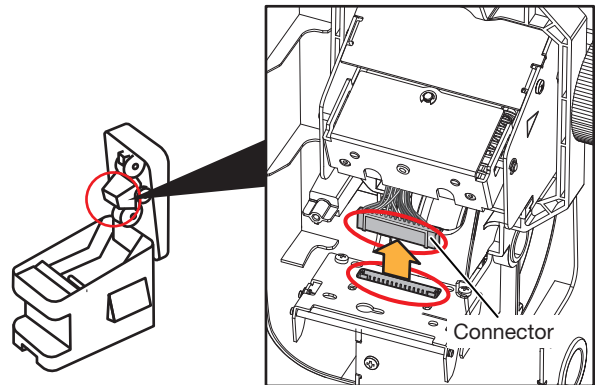

- 2 Mount the thermal head and slide it to the left.

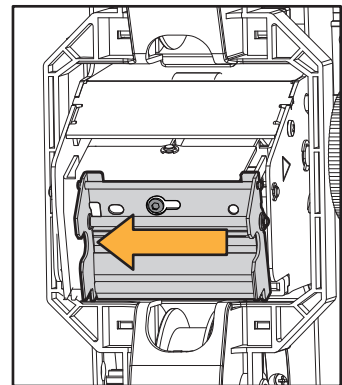

- 3 Check that the holes at either end of the thermal head are attached to the protrusions on the head mounting section.

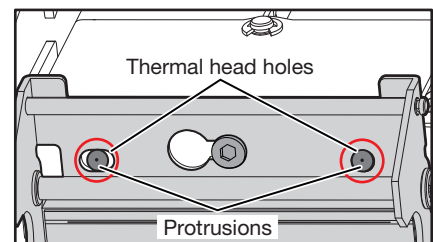

- 4 Press down on both ends of the thermal head to ensure that the holes and the protruding sections do not become misaligned, then turn the hexagon socket head bolt clockwise to tighten it. Thermal head mounting is now complete.

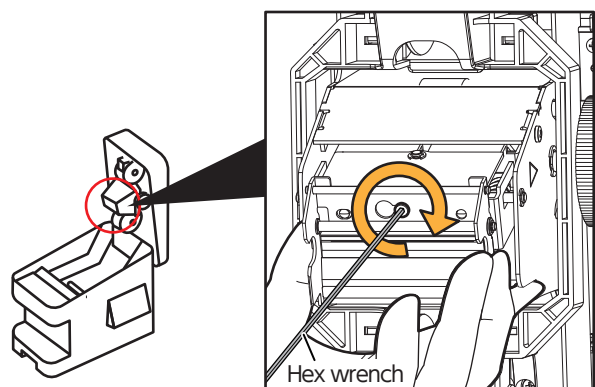

# Chapter 6

## MAIN UNIT LCD DISPLAY

### CONTENT

---

6-1 HOME SCREEN.....	79
6-2 PRINTING .....	80
6-3 FEEDING.....	83
6-4 REMOVING USB MEMORY DEVICES .....	83
6-5 SWITCHING THE HEATER ON AND OFF .....	84
6-6 HELP .....	84
6-7 SETTINGS.....	85
6-8 MAIN UNIT SETTINGS .....	86
6-8-1 SLEEP TIMER.....	86
6-8-2 TOUCH SOUND SETTINGS.....	87
6-8-3 ADJUSTING THE TOUCH PANEL.....	87
6-8-4 SETTING POWER INTERRUPTION PRINT RESTART MODE.....	88
6-8-5 ADJUSTING SCREEN SETTINGS.....	88
6-9 PRINT SETTINGS.....	89
6-9-1 SETTING THE PRINTING DENSITY .....	90
6-9-2 SETTING LOW TEMPERATURE MODE .....	90
6-9-3 SETTING PRE-PRINT FEEDING.....	91
6-9-4 SETTING THE PRINTING LINE POSITION.....	91
6-9-5 SETTING THE CUTTING POSITION .....	92
6-9-6 HORIZONTAL PRINTING LINE POSITION .....	92
6-9-7 POST-PRINT FEEDING .....	93
6-9-8 MARGINS BETWEEN PRINT FILES .....	93
6-9-9 ADJUSTING THE BLOCK MARKER SENSOR.....	94
6-9-10 SETTING THE HEATER TEMPERATURE .....	94
6-9-11 SETTING THE HEAT RETENTION .....	95
6-10 CONNECTION SETTINGS.....	96
6-10-1 INITIALIZING LAN SETTINGS .....	96

# 6-1 HOME SCREEN

The LCD display is a touch panel. Perform operation by touching the icons with your fingertips or a stylus. Connect the power cord to the main unit, turn on the main power switch, then press the secondary power button.

→ 3-2 PART NAMES



## MEMO

- When printing from LETATWIN PC EDITOR PRO, check that the main unit is on the home screen. Printing from LETATWIN PC EDITOR PRO cannot be performed while the main unit is on screens other than the home screen.

## 6-2 PRINTING

Printing can be performed using only the main unit if a document created using LETATWIN PC EDITOR PRO is saved onto a USB memory device in advance. [→ 8-10 SAVING AND SENDING FILES](#)

\* Documents cannot be input on the main unit.

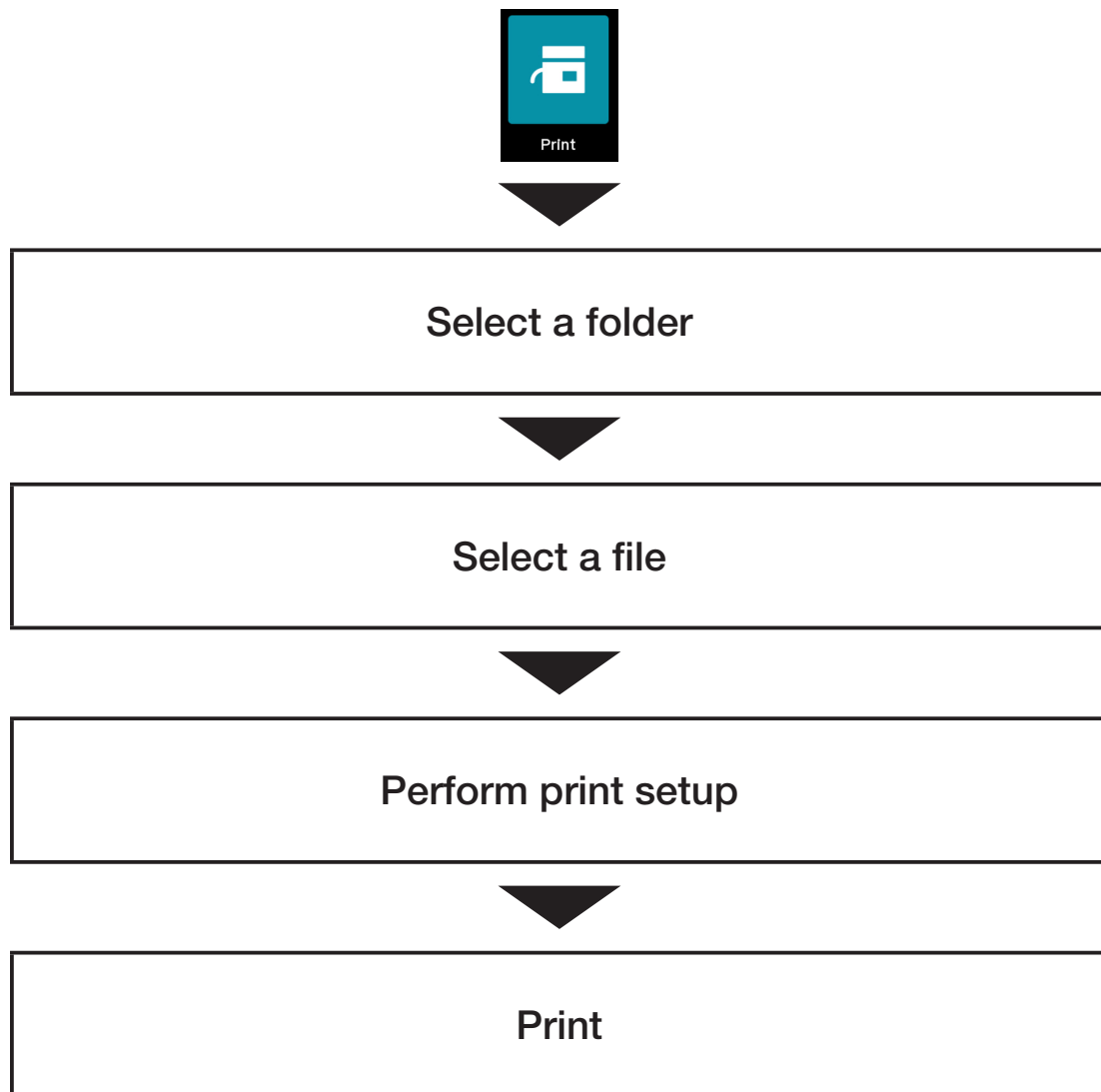

When a USB memory device is inserted into the main unit, the  symbol is displayed and documents can be selected and printed.

\* USB memory devices with security functions cannot be used.

Double-sided printing (grip sleeves): [→ 8-11 DOUBLE-SIDED PRINTING](#)

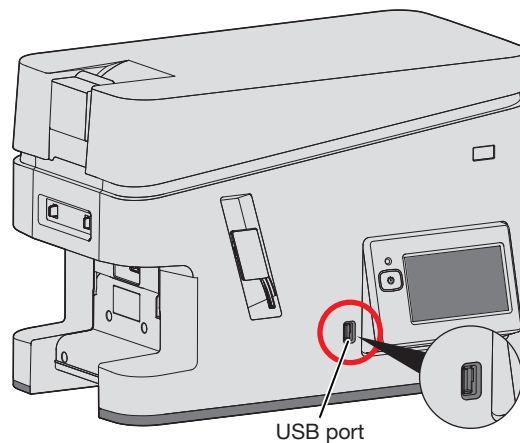

- 1 Press the “Print” button.

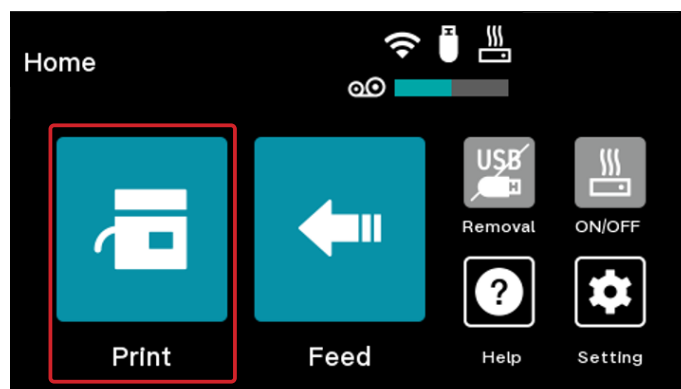

- 2 Select a folder.

The data saved on the USB memory device is displayed.

To scroll the folder list, use the  keys. Select a folder.

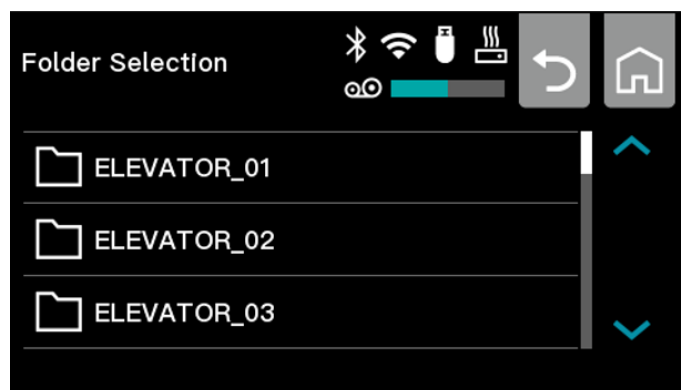

- 3 Select a file.

Select a file, then press the “OK” button.

The print material set when each document was created is displayed.

 Click on the icon to display each file's comments.

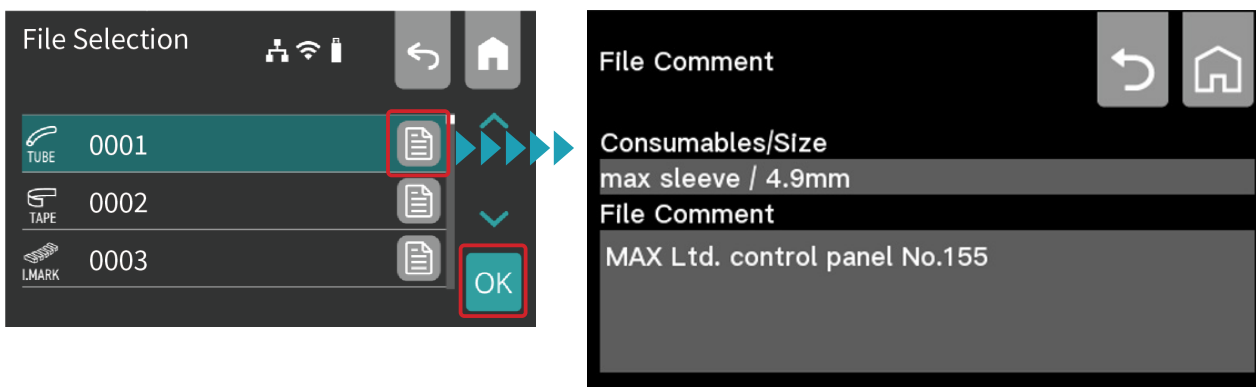

#### MEMO

- A maximum of 50 characters (single byte) can be displayed for folder names and file names.
- A maximum of 100 files/folders can be displayed.

**4** On the print settings screen, the number of print copies, alignment and print range can be set. The  keys can be used to switch the item being set.



After entering a setting value for each setting, check that the print material has been loaded, then press the **Print** button. Printing begins.

**5** Set the number of copies to be printed.

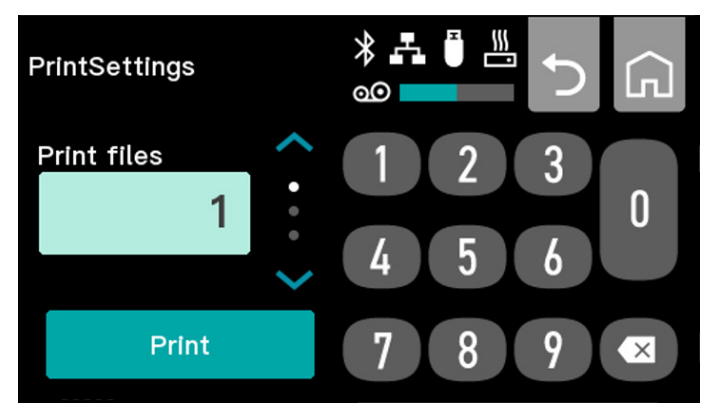

**6** Set the start block and the end block. Select the print range within documents.

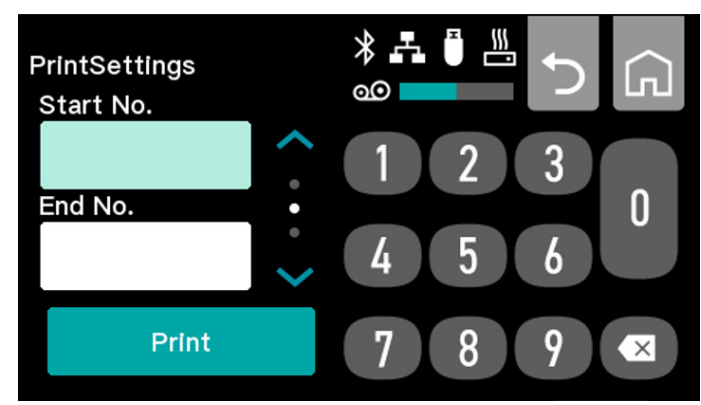

**7** Enter the alignment adjustment value. When the actual print length differs from the set length, the overall print material length can be adjusted before printing. For the alignment value, enter the difference between the actual print length and the set length. The allowable alignment setting range varies depending on the overall print material length and the number of copies being printed.

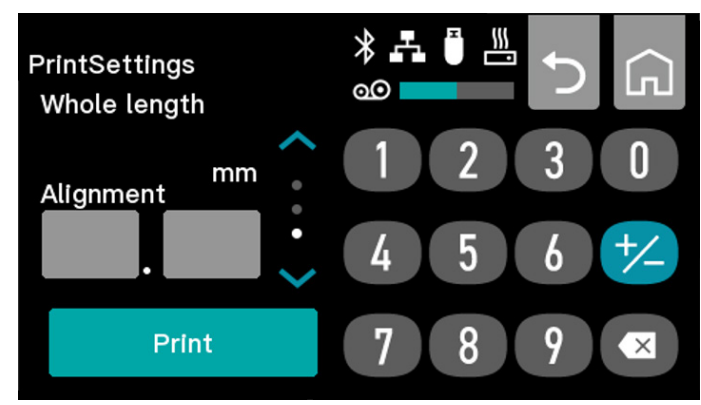

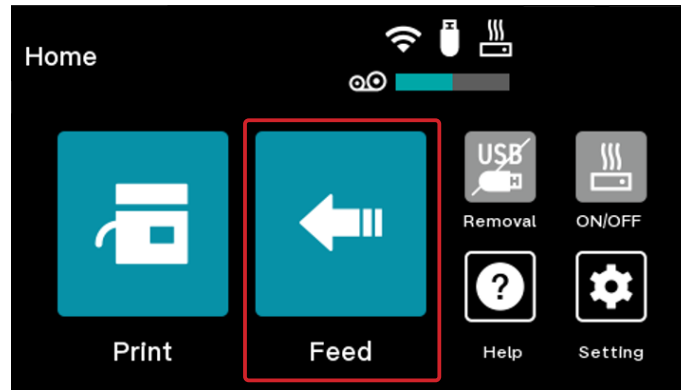

## 6-3 FEEDING

Feeds the material to a position where it can be cut by hand with scissors or similar tools.



## 6-4 REMOVING USB MEMORY DEVICES

When removing a USB memory device, to ensure safe removal and prevent data on the USB memory device from becoming corrupted, turn off the flow of electricity to the USB memory device. When removing a USB memory device, always press the  key and ensure that the  icon has turned off before removal.

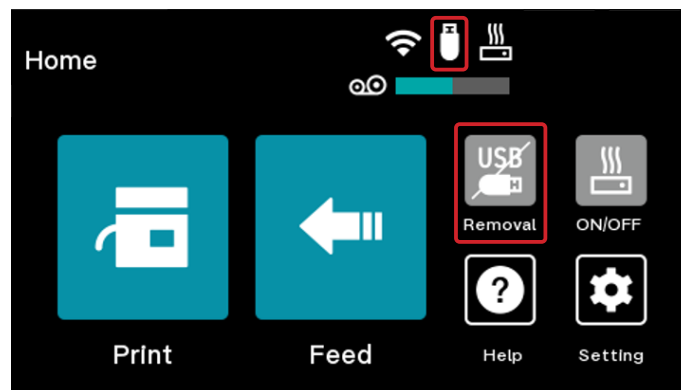

## 6-5 SWITCHING THE HEATER ON AND OFF

In low temperature environments of 5 to 15°C, tubes may harden and printed text may become blurred or faint. In such cases, the tube heater can be used to heat tubes to soften them and improve print quality.

The heater can only be used with tubes between  $\phi 1.5$  and  $\phi 4.6$ . It cannot be used with other print materials. When the heater is on, the section of the print material that is not heated while loaded is output before printing begins. As a result, the leading margin is made longer.

The heater cannot be turned on or off using LETATWIN PC EDITOR PRO.

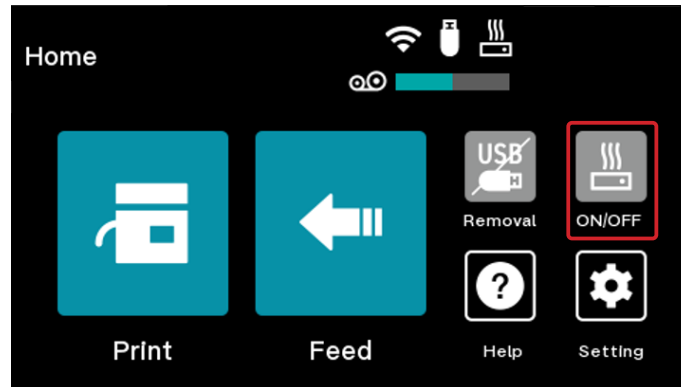

### SETTING THE TUBE HEATER IN POSITION

→ 4-5-1 SETTING THE TUBE HEATER IN POSITION

## 6-6 HELP





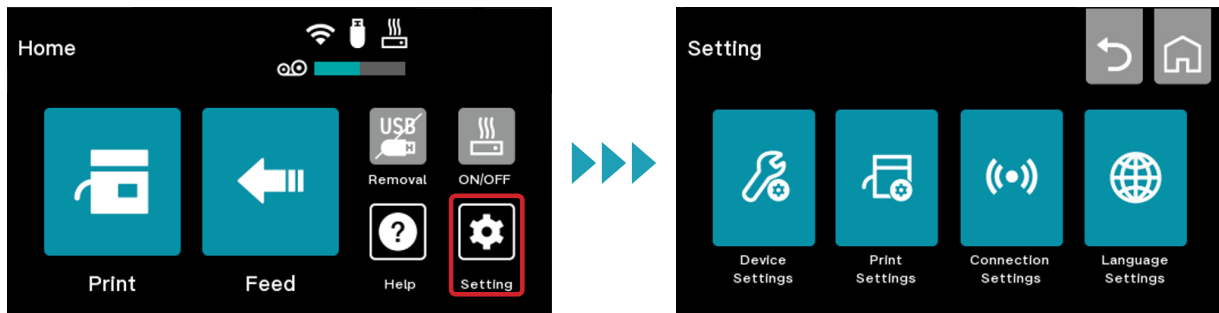

### Help menu functions

01 Maintenance	Displays a QR code linking to the MAX website. The website offers access to instruction manuals and instructional videos.
02 Main unit information	Used to check the machine's version information, model name, serial number, MAC address and IP address.
03 Version update	Used to perform version updates for the main unit. Follow the on-screen instructions to perform updates.
04 Platen roller drive	Rotates the platen roller in the regular direction or in reverse. If the platen roller cannot be removed for reasons such as print material that has become entangled, rotate the platen roller to remove the obstruction.

# 6-7 SETTINGS



## Setting items

 Main unit settings	01 Sleep timer	
	02 Touch sound	
	03 Touch panel adjustment	
	04 Power interruption print restart mode	
	05 Screen adjustment	01 Brightness 02 Luminance 03 Contrast
 Print settings	01 Printing density	
	02 Low temperature mode	
	03 Pre-print feed	
	04 Printing line position	
	05 Cutting position	
	06 Horizontal printing line position	
	07 Post-print feed	
	08 Margins between print files	
	09 Block marker sensor adjustment	
	10 Heater temperature settings	
	11 Heater heat retention settings	
 Connection settings	01 Communication interface	
	02 Wired LAN settings	01 IP address settings
		02 Default gateway
		03 Subnet mask
	03 Wireless LAN settings	01 IP address settings
		02 Default gateway
		03 Subnet mask
		04 WPS
05 SSID		
04 Initialize		
 Language settings	Language selection → 3-5 LANGUAGE SETTINGS	

# 6-8 MAIN UNIT SETTINGS

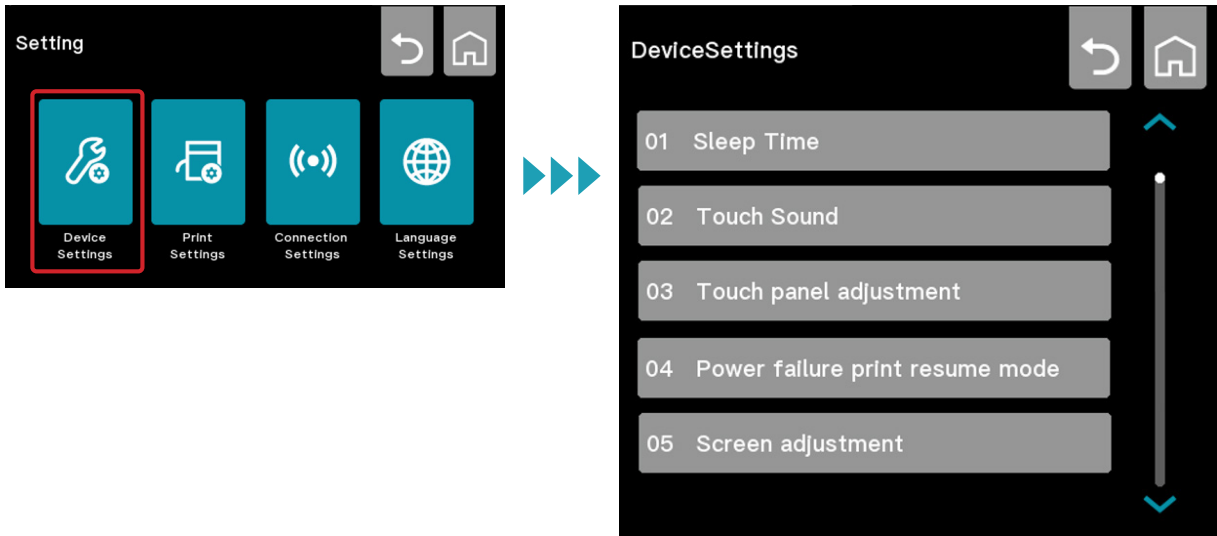

		Initial value	
 Main unit settings	01 Sleep timer	15 minutes	
	02 Touch sound	ON	
	03 Touch panel adjustment	—	
	04 Power interruption print restart mode	ON	
	05 Screen adjustment	01 Brightness	5
		02 Luminance	10
03 Contrast		10	

## 6-8-1 SLEEP TIMER

### Sleep timer (Initial value: 15 minutes)

Set the time before the LCD display enters sleep mode.

Select OFF, 15 minutes, 30 minutes or 60 minutes, then press the “OK” button.

Pressing the secondary power button on the home screen also puts the machine into sleep mode.

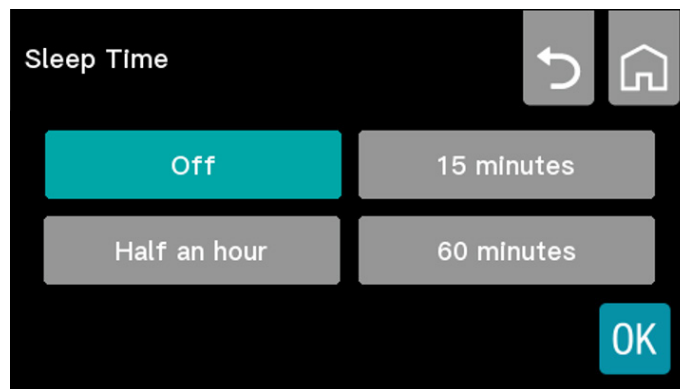

## 6-8-2 TOUCH SOUND SETTINGS

---

### Touch sound (Initial value: ON)

Turns LCD display touch sounds on and off.  
Select OFF or ON, then press the "OK" button.

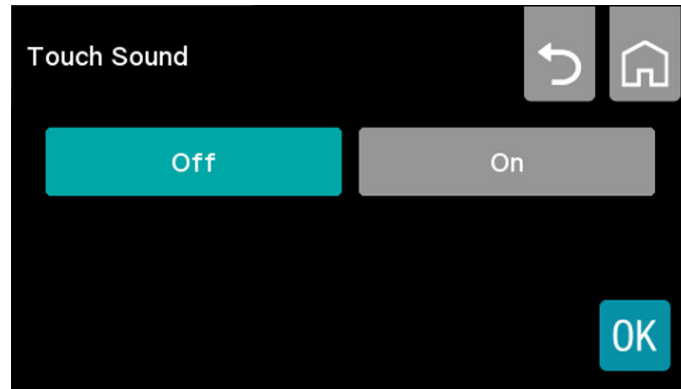

## 6-8-3 ADJUSTING THE TOUCH PANEL

---

### Touch panel adjustment (Initial value: -)

Adjust the screen display position. Use a stylus to perform operation.  
Touch the screen in accordance with the on-screen instructions.

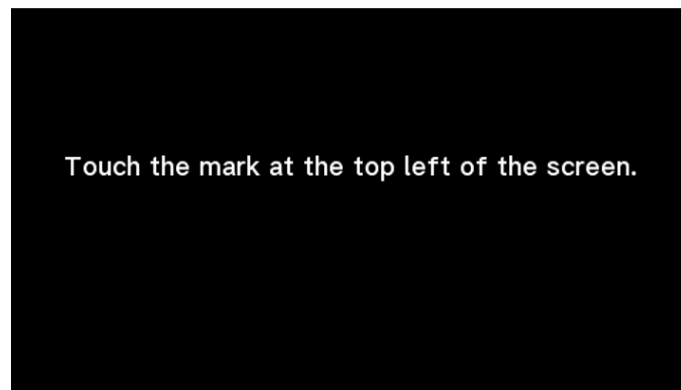

## 6-8-4 SETTING POWER INTERRUPTION PRINT RESTART MODE

### Power interruption print mode (Initial value: ON)

This mode restarts printing from the in-progress position in the event that the power is interrupted. Select OFF or ON, then press the “OK” button.

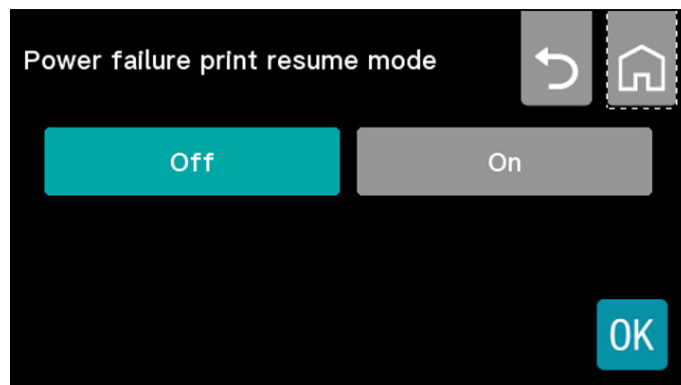

#### MEMO

- When set to ON, a delay of several seconds occurs before printing begins each times.

## 6-8-5 ADJUSTING SCREEN SETTINGS

### Screen adjustment (Initial values: Brightness: 5 / Luminance: 10 / Contrast: 10)

Set the brightness, luminance and contrast of the LCD display. Select the items to be set. After performing setting, press the “OK” button.

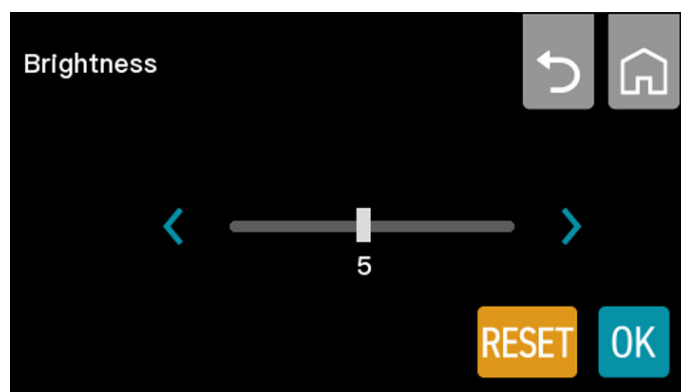

# 6-9 PRINT SETTINGS

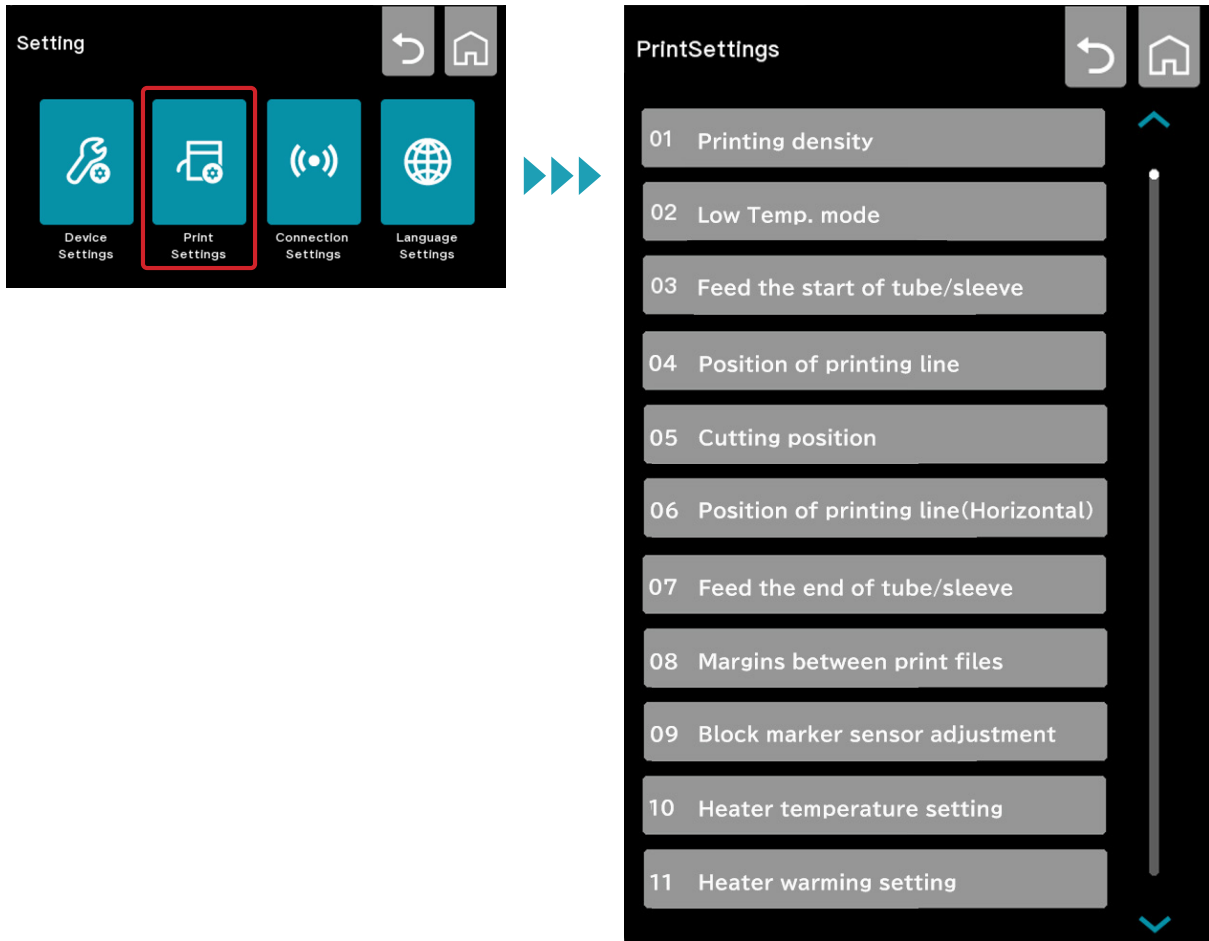

		Initial value
 Print settings	01 Printing density	5
	02 Low temperature mode	OFF
	03 Pre-print feed	OFF
	04 Printing line position	0.0mm
	05 Cutting position	0.0mm
	06 Horizontal printing line position	0.0mm
	07 Post-print feed	ON
	08 Margins between print files	ON
	09 Block marker sensor adjustment	—
	10 Heater temperature settings	Medium
	11 Heater heat retention settings	OFF

When printing with LETATWIN PC EDITOR PRO, for setting items 01 to 08 above, the user can select whether to apply settings from the main printer unit or the settings from LETATWIN PC EDITOR PRO when printing.

## 6-9-1 SETTING THE PRINTING DENSITY

### Printing density (Initial value: 5)

Set the printing density, then press the "OK" button.



#### MEMO

- If the ink ribbon and consumables stick together, try reducing the printing density.

## 6-9-2 SETTING LOW TEMPERATURE MODE

### Low Temperature mode (Initial value: OFF)

In environments with a temperature of 5 to 15°C, text printed on tubes may become faint. In such cases, try setting the machine to low speed mode.

Select OFF or ON, then press the "OK" button.

[→ 8-3-1 USING THE TUBE HEATER](#)

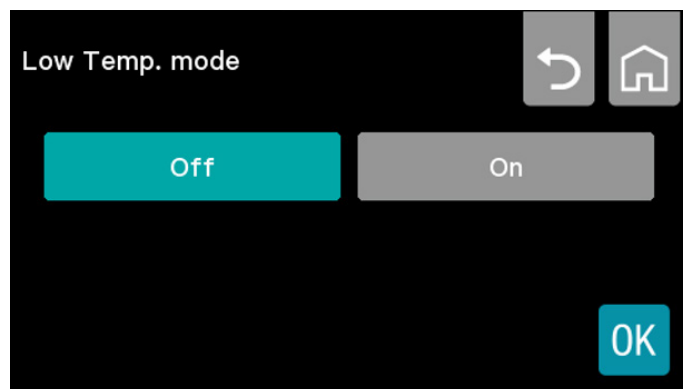

## 6-9-3 SETTING PRE-PRINT FEEDING

### Pre-print feed (Initial value: OFF)

Feeds the start of the print material before printing.

Select OFF, ON or AUTO, then press the "OK" button.

→ 8-8-9 PRE-PRINT FEEDING

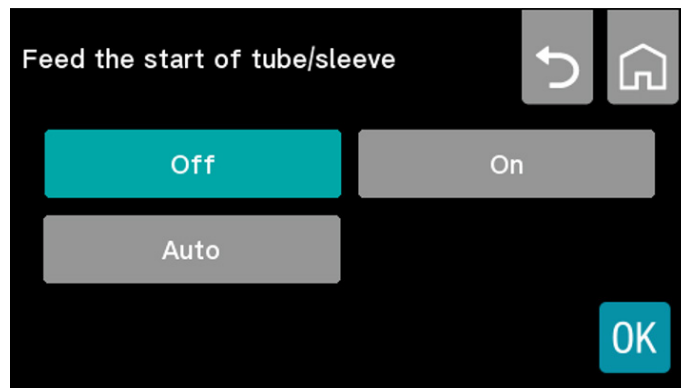

## 6-9-4 SETTING THE PRINTING LINE POSITION

### Printing line position (Initial value: 0.0mm)

Adjusts the vertical position of the printing line.

Enter the adjustment value, then press the "OK" button.

→ 8-8-7 SETTING THE PRINTING LINE POSITION

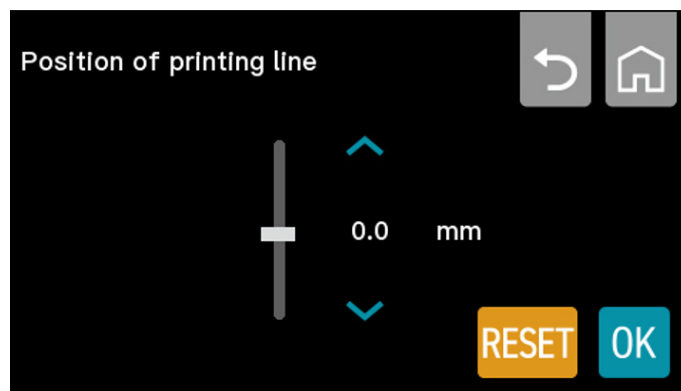

## 6-9-5 SETTING THE CUTTING POSITION

### Cutting position (Initial value: 0.0mm)

When the print position is off center, adjust the half cutting position so that the print position is in the center. Enter the adjustment value, then press the "OK" button.

→ 8-8-6 SETTING THE CUTTING POSITION

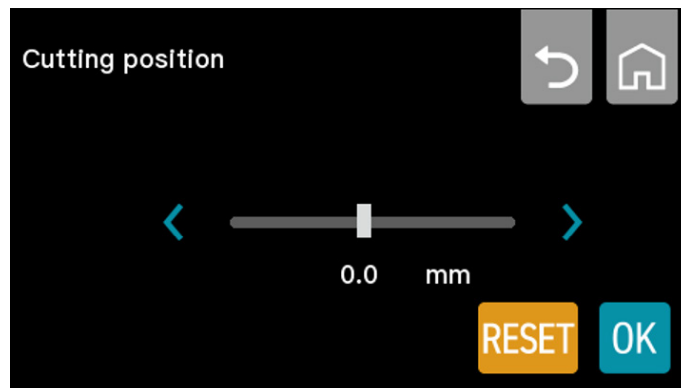

## 6-9-6 HORIZONTAL PRINTING LINE POSITION

### Horizontal printing line position (Initial value: 0.0mm)

Adjusts the horizontal position of the printing line for block markers. Enter the adjustment value, then press the "OK" button.

→ 8-8-11 ADJUSTING THE HORIZONTAL PRINTING LINE POSITION (BLOCK MARKERS ONLY)

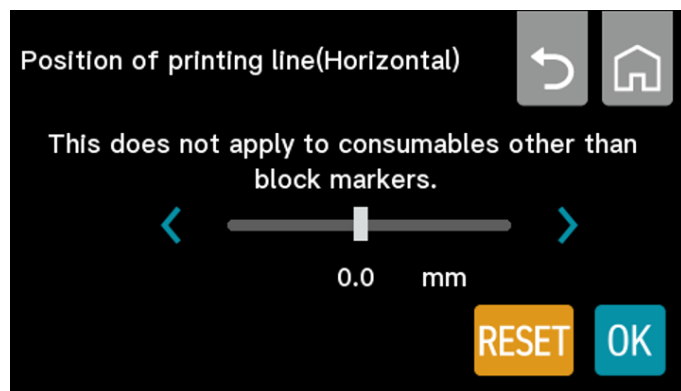

## 6-9-7 POST-PRINT FEEDING

---

### Post-print feeding (Initial value: ON)

Select OFF or ON, then press the “OK” button.

→ 8-8-8 SETTING POST-PRINT FEEDING

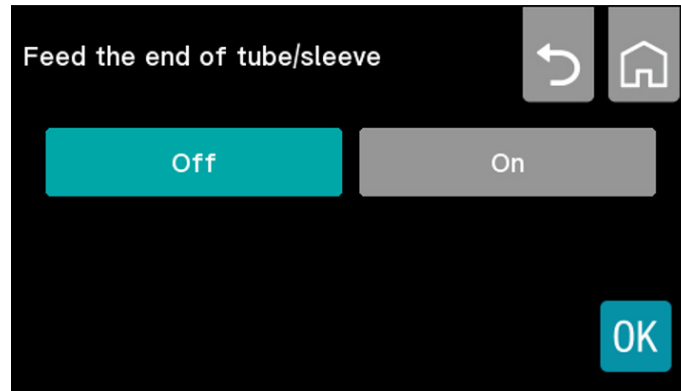

## 6-9-8 MARGINS BETWEEN PRINT FILES

---

### Margins between print files (Initial value: ON)

Select OFF or ON, then press the “OK” button.

→ 8-8-10 SETTING MARGINS BETWEEN PRINT FILES

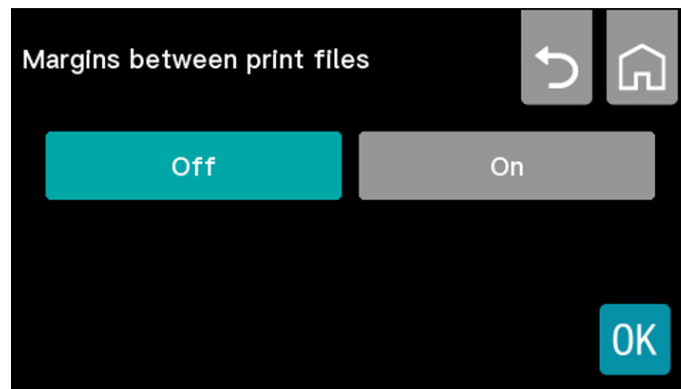

## 6-9-9 ADJUSTING THE BLOCK MARKER SENSOR

### Block marker sensor adjustment

If the block marker horizontal printing line position is misaligned, or when printing on block markers for the first time, the tip sensor must be adjusted.

Select the block marker type, check that the block markers are loaded into the main unit, then press the "OK" button.

Do not pull on the block markers when loading them. Doing so may prevent accurate detection.

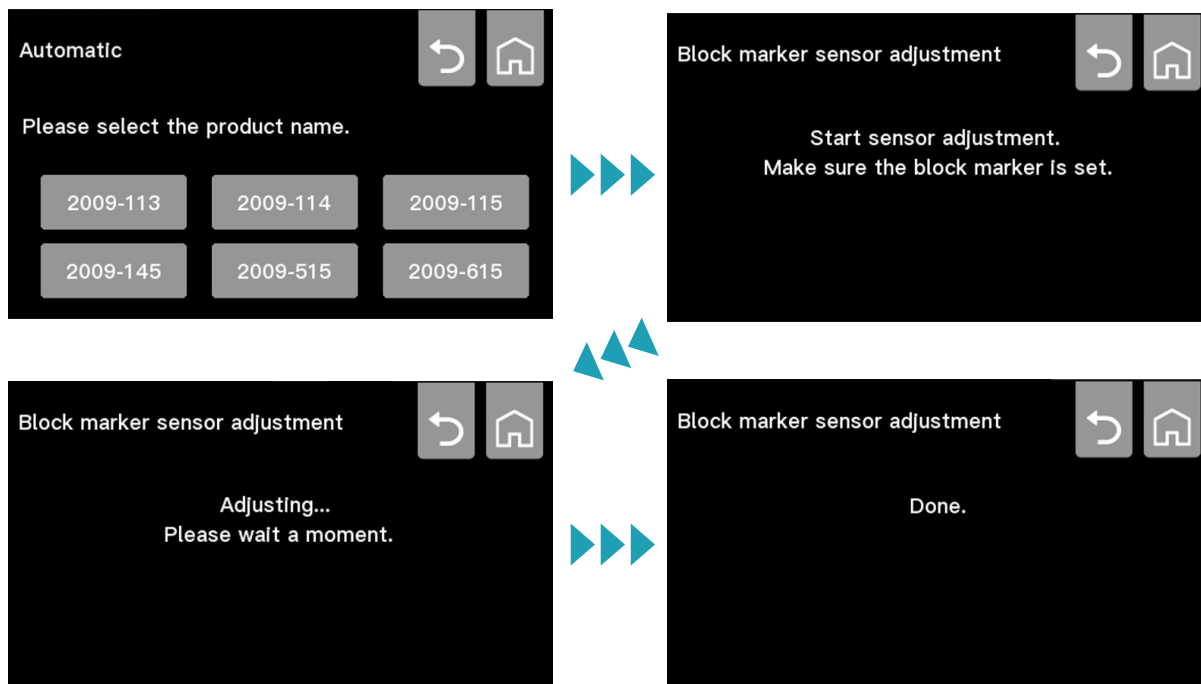

## 6-9-10 SETTING THE HEATER TEMPERATURE

### Heater temperature setting (Initial value: Medium)

Select "High," "Medium" or "Low," then press the "OK" button.

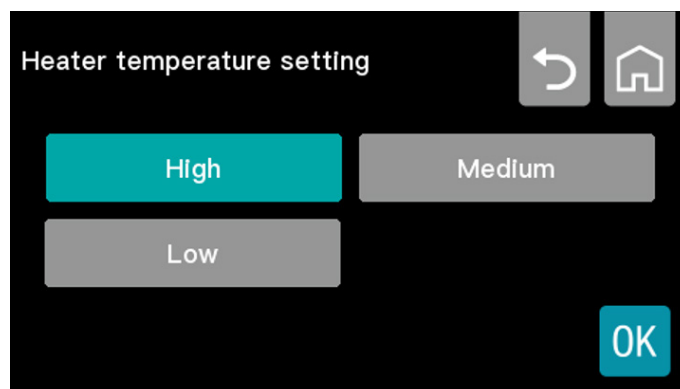

## 6-9-11 SETTING THE HEAT RETENTION

### Heater heat retention setting (Initial value: OFF)

In this mode, the tube heater remains at a consistent temperature. This reduces the time taken for print material to be heated up.

Select OFF or ON, then press the “OK” button.

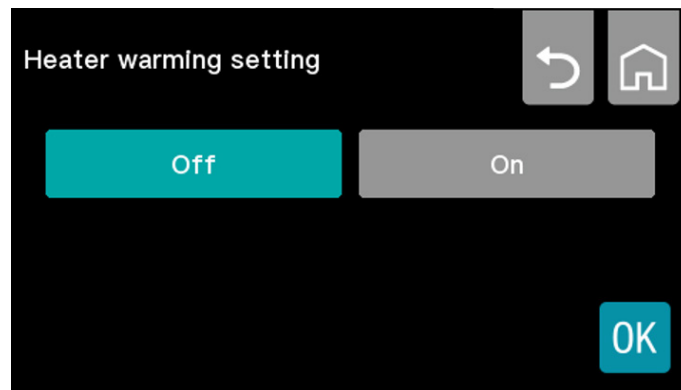

# 6-10 CONNECTION SETTINGS

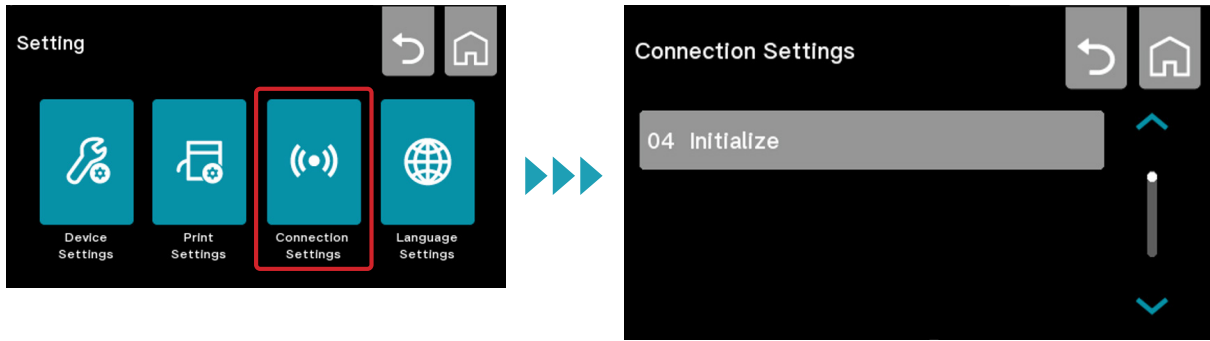

 Connection settings	01 Communication interface → <b>3-7 CONNECTING THE MAIN UNIT TO A COMPUTER</b>	
	02 Wired LAN settings	01 IP address settings
		02 Default gateway
		03 Subnet mask
03 Wireless LAN settings	01 IP address settings	
	02 Default gateway	
	03 Subnet mask	
	04 WPS	
	05 SSID	
04 Initialize		

## 6-10-1 INITIALIZING LAN SETTINGS

### Initialize

Initializes items that have been set in the wired LAN and wireless LAN settings.

The following items are initialized: IP address, default gateway, subnet mask, SSID, password.

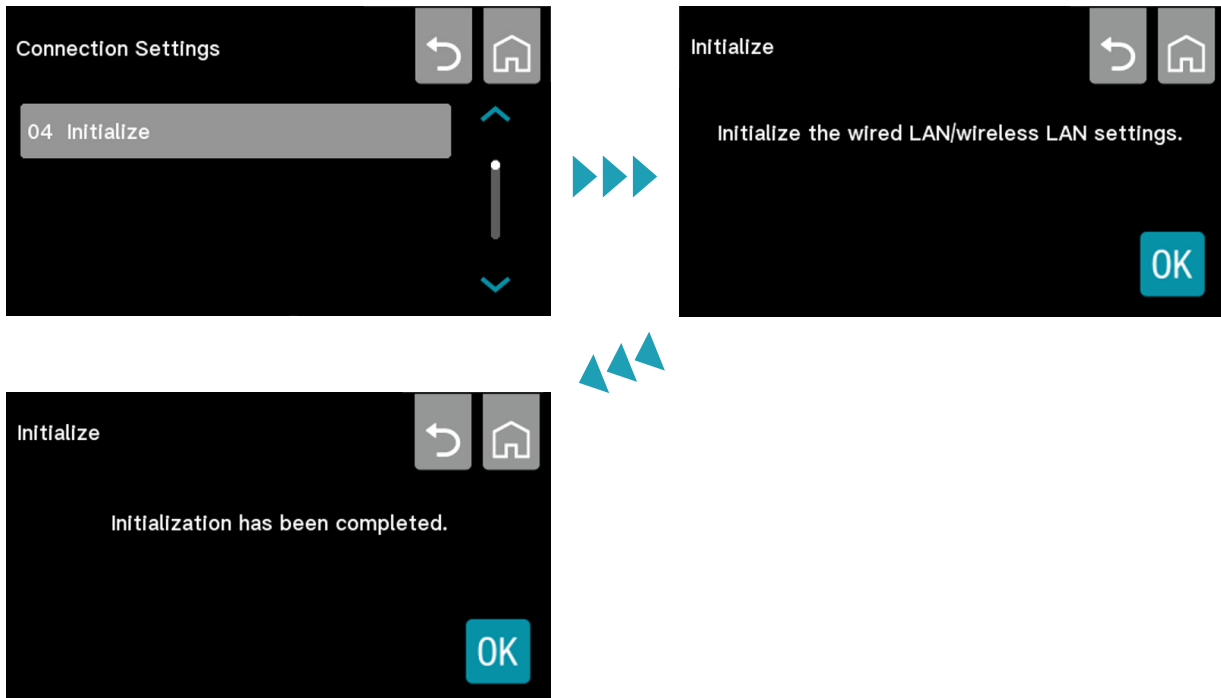

- When disposing of the product, initialize the wireless settings. If you dispose of the product without initializing it, there is a risk that your wireless settings may be revealed.

# Chapter 7

## BASIC PROCEDURE FROM TEXT INPUT TO PRINTING

---

<b>7-1 BASIC LETATWIN PC EDITOR PRO OPERATIONS .....</b>	<b>98</b>
7-1-1 LAUNCHING LETATWIN PC EDITOR PRO .....	99
7-1-2 SELECTING THE MODEL .....	99
7-1-3 SELECTING PRINT MATERIAL .....	100
7-1-4 PRINT FORMAT.....	101
7-1-5 LETATWIN PC EDITOR PRO MAIN EDITOR SCREEN LAYOUT .....	102
7-1-6 ENTER DOCUMENTS .....	103
7-1-7 CHECKING PRINT DATA USING PREVIEWS.....	104
7-1-8 PRINTING.....	105

# 7-1 BASIC LETATWIN PC EDITOR PRO OPERATIONS

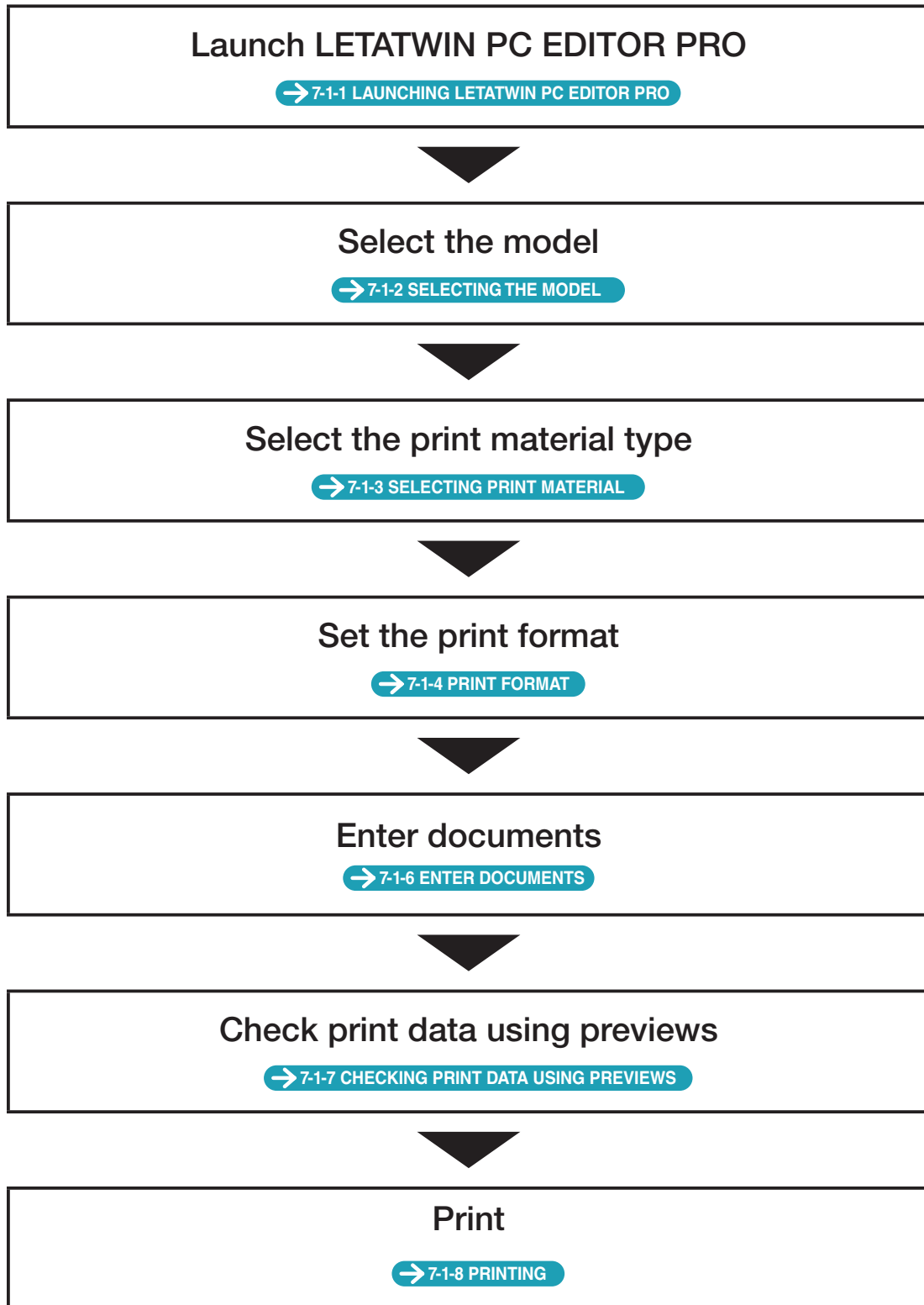

## 7-1-1 LAUNCHING LETATWIN PC EDITOR PRO

Double click on the **LT** icon.

LETATWIN PC EDITOR PRO launches.

## 7-1-2 SELECTING THE MODEL

All creation and editing of print data is performed using LETATWIN PC EDITOR PRO. Documents cannot be created using the LM-3000PRO main unit only.

- 1 Launch LETATWIN PC EDITOR PRO. The “1. Model settings” screen opens.  
Select LM-3000PRO, then click “Next.”

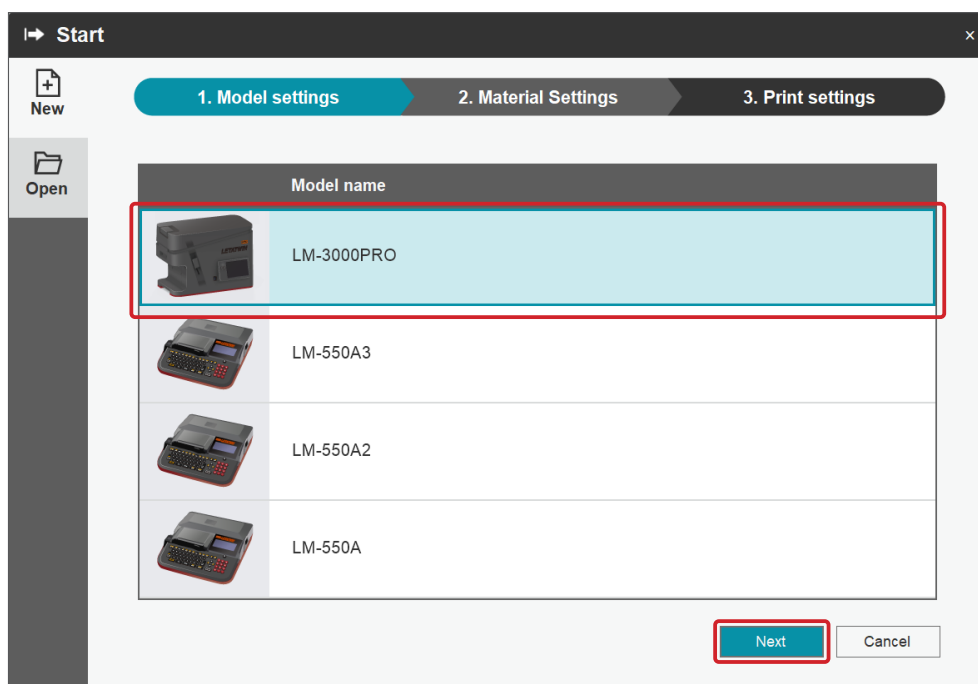

### MEMO

- All models displayed on the “1. Model settings” screen can be used with LETATWIN PC EDITOR PRO.

## 7-1-3 SELECTING PRINT MATERIAL

1 On the “2. Material settings” screen, select the print material to be used, then click “Next.”

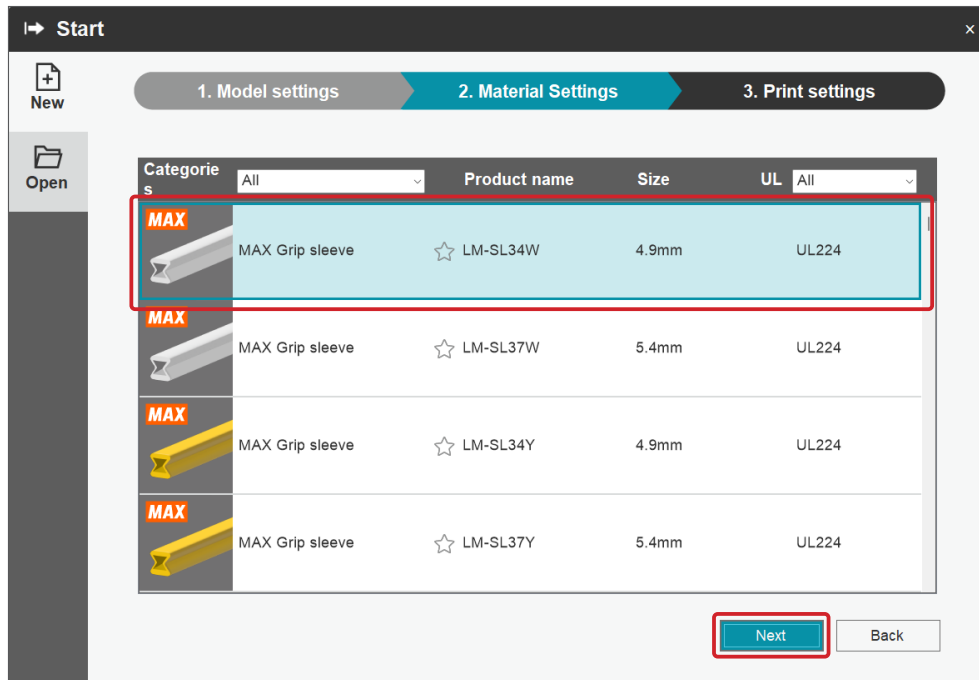

### MEMO

- Clicking on the ☆ icon adds an item to Favorites. Items in Favorites can be selected from a pull-down menu.
- UL224-certified print materials can be selected from the UL pull-down menu.
- Print materials not shown on the material settings screen cannot be used with this product.
- Print materials that are grayed out and cannot be selected are not compatible with the model selected on the “1. Model settings” screen.

## 7-1-4 PRINT FORMAT

1 On the “3. Print settings” screen, select the format settings, then click “OK.”

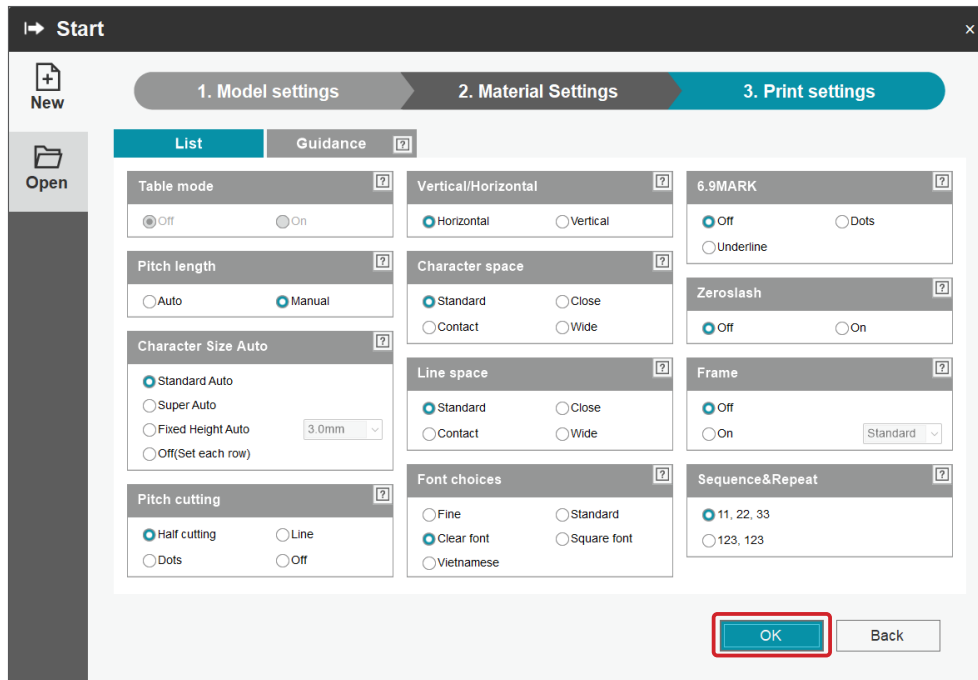

### MEMO

- The “Print settings” screen is also displayed and editable on the main screen shown on the next page.
- For each setting item, clicking on the **?** button shows the guidance display, through which setting can be performed.
- The print settings can be registered as the default settings (initial values).

→ 8-9 REGISTERING DEFAULT SETTINGS (INITIAL VALUES)

### Guidance display screen

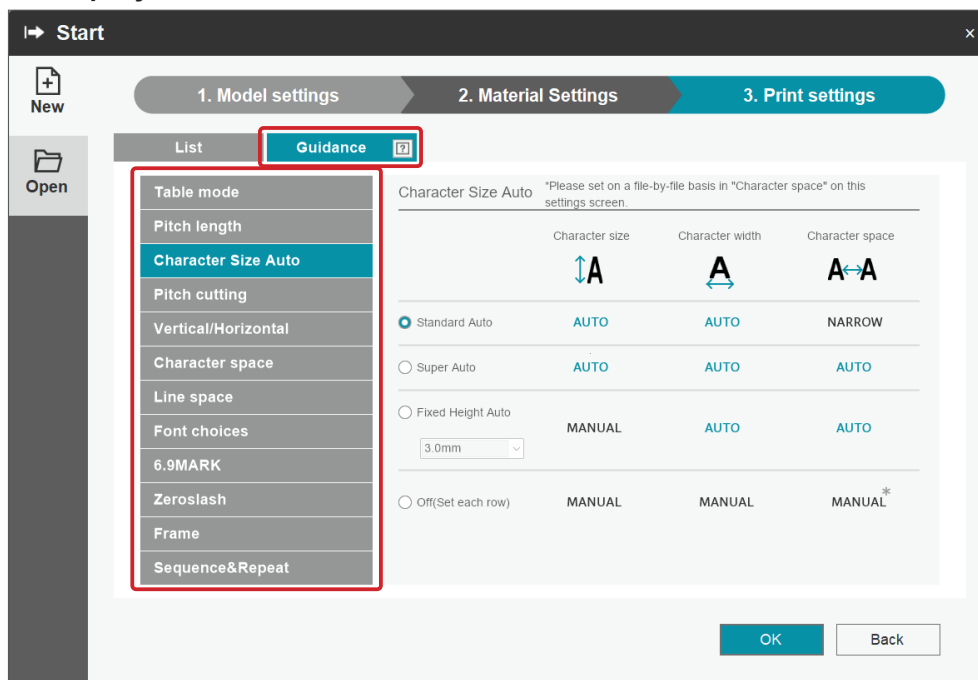

# 7-1-5 LETATWIN PC EDITOR PRO MAIN EDITOR SCREEN LAYOUT

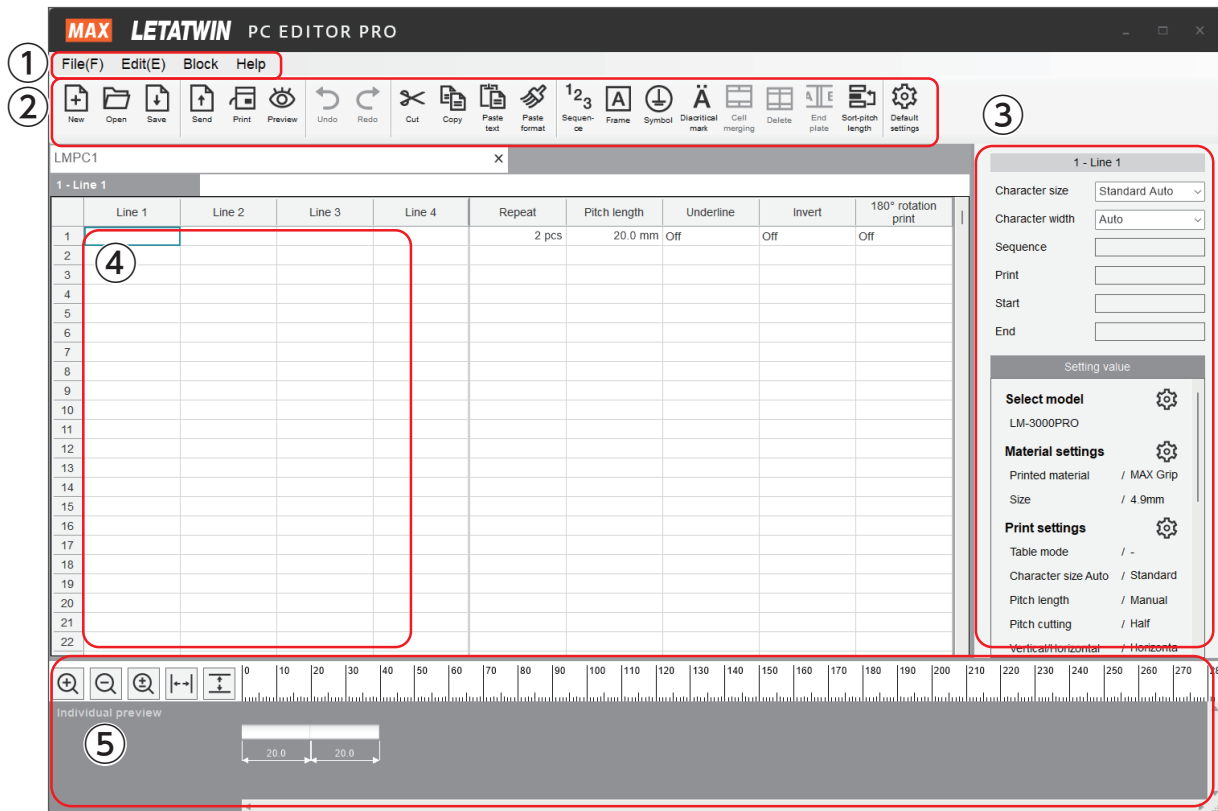

①	Menu bar
②	Tool bar
③	Settings window
④	Editing window
⑤	Separate preview window

## 7-1-6 ENTER DOCUMENTS

**1** Open the main editing screen and enter documents.

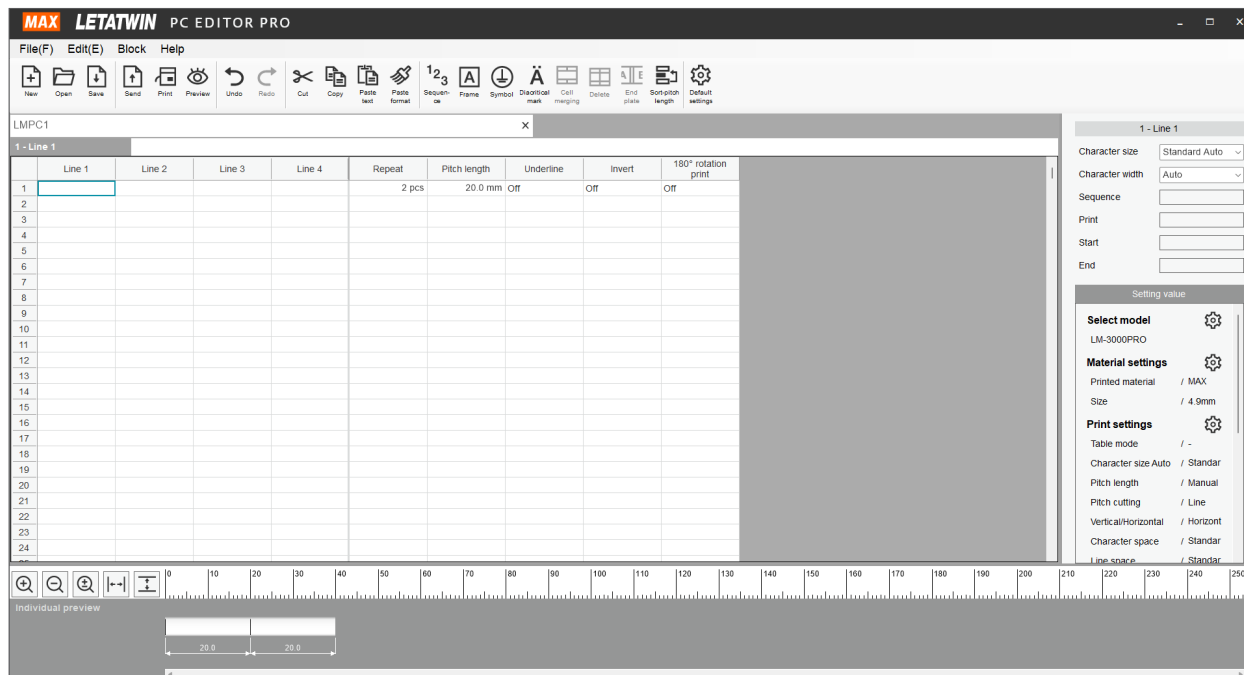

### Example input

Perform input, using the print material below as an example.



First block →  
Second block →  
Third block →

	Line 1	Line 2	Line 3	Line 4	Repeat	Pitch length	Underline	Invert	180° rotation print
1	A				2 pcs	20.0 mm	Off	Off	Off
2	B				2 pcs	20.0 mm	Off	Off	Off
3	C				2 pcs	20.0 mm	Off	Off	Off

### MEMO

- Input cannot be performed if the pitch length for the previous block has not been set.
- Previously saved files can be loaded and edited.
- CSV files created in spreadsheet software can be loaded and edited.  
→ 9-3 IMPORTING CSV FILES
- The maximum number of blocks that can be entered is 2,000 for the LM-3000 PRO, 999 for the LM-550A3/550A2, and 300 for the LM-550A.

# 7-1-7 CHECKING PRINT DATA USING PREVIEWS

The content to be printed can be checked on the individual preview screen.

**1** To see a preview of all entered documents, click  icon.

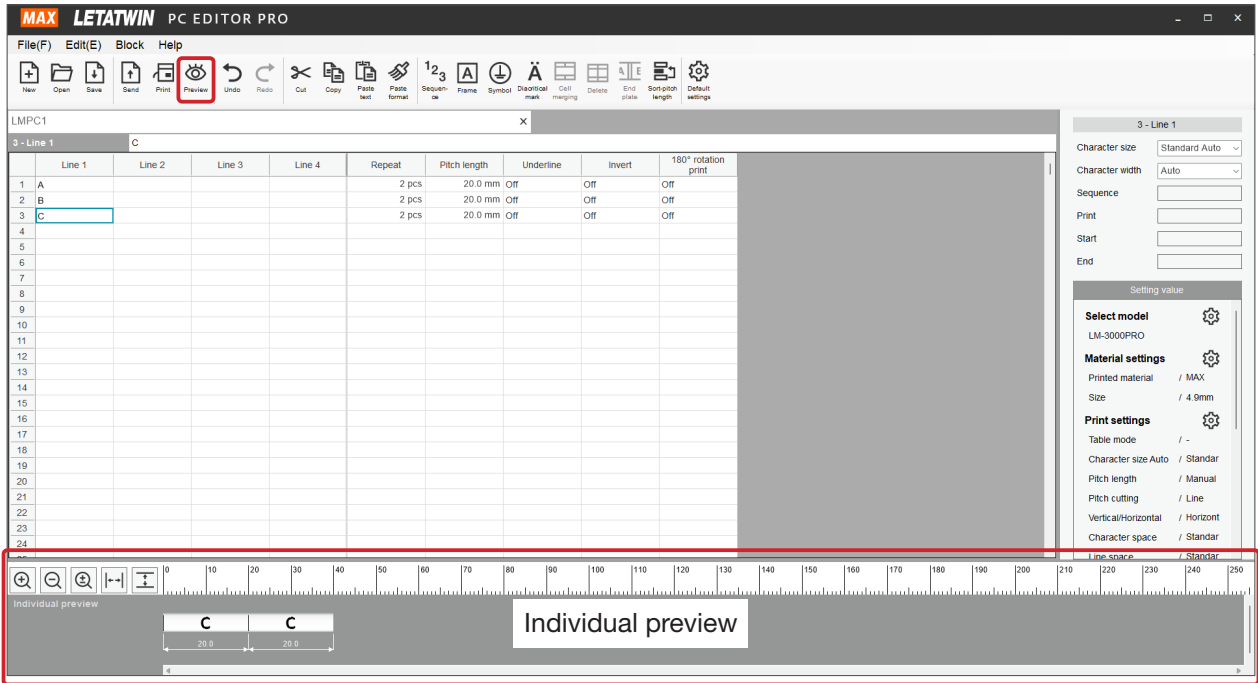

Full preview screen

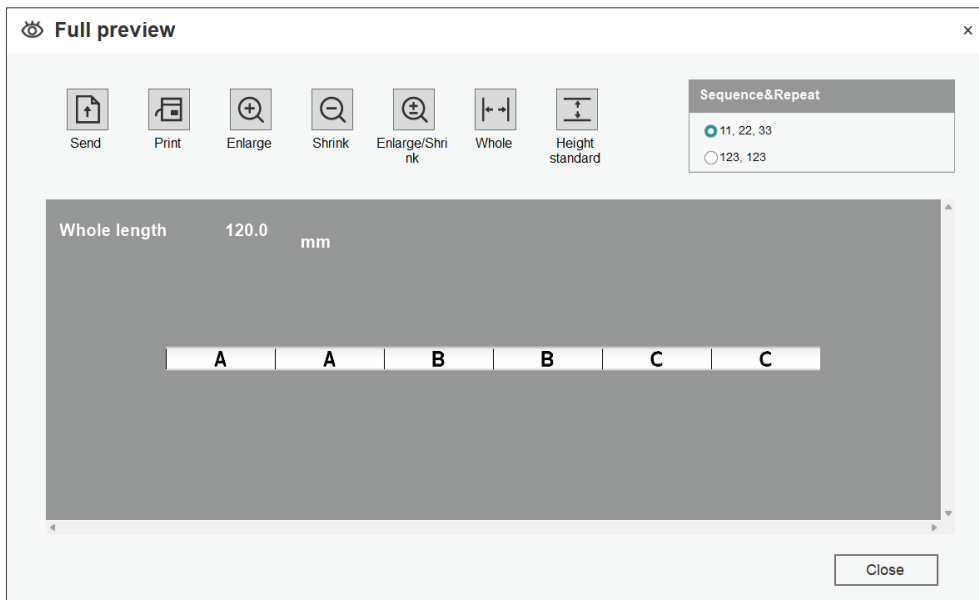

## 7-1-8 PRINTING

Printing can be performed from the main editing screen or the full preview screen.

1 Click  icon.

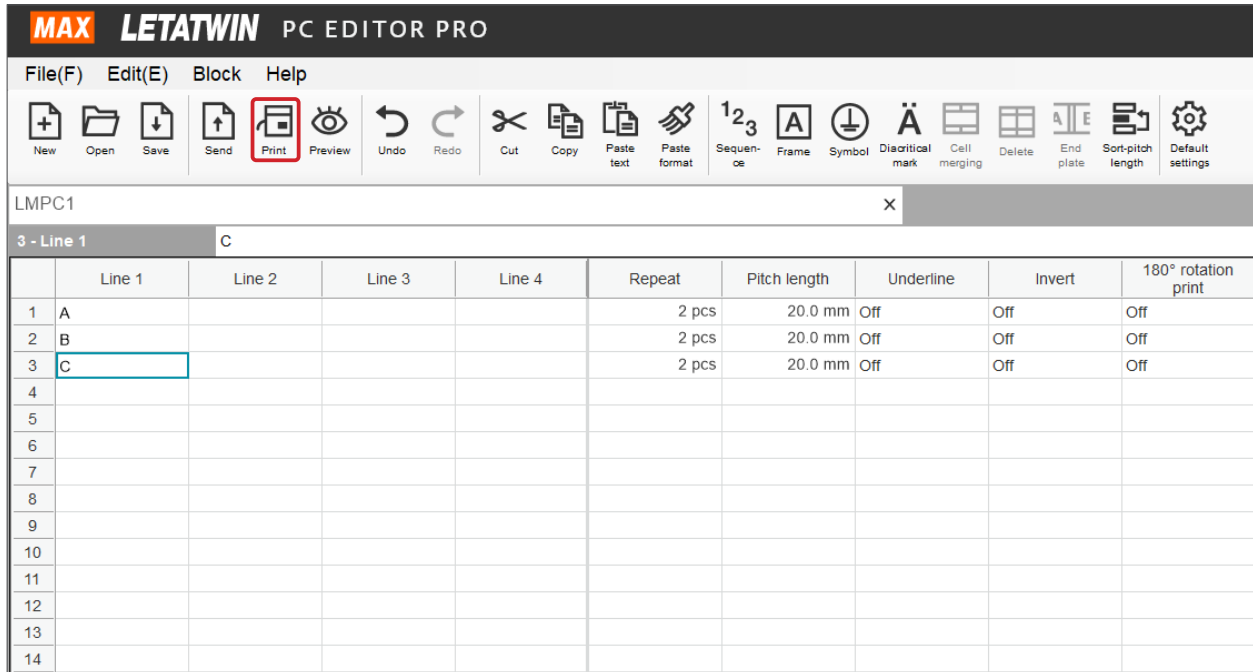

	Line 1	Line 2	Line 3	Line 4	Repeat	Pitch length	Underline	Invert	180° rotation print
1	A				2 pcs	20.0 mm	Off	Off	Off
2	B				2 pcs	20.0 mm	Off	Off	Off
3	C				2 pcs	20.0 mm	Off	Off	Off
4									
5									
6									
7									
8									
9									
10									
11									
12									
13									
14									

2 Click the “Print” button to print.

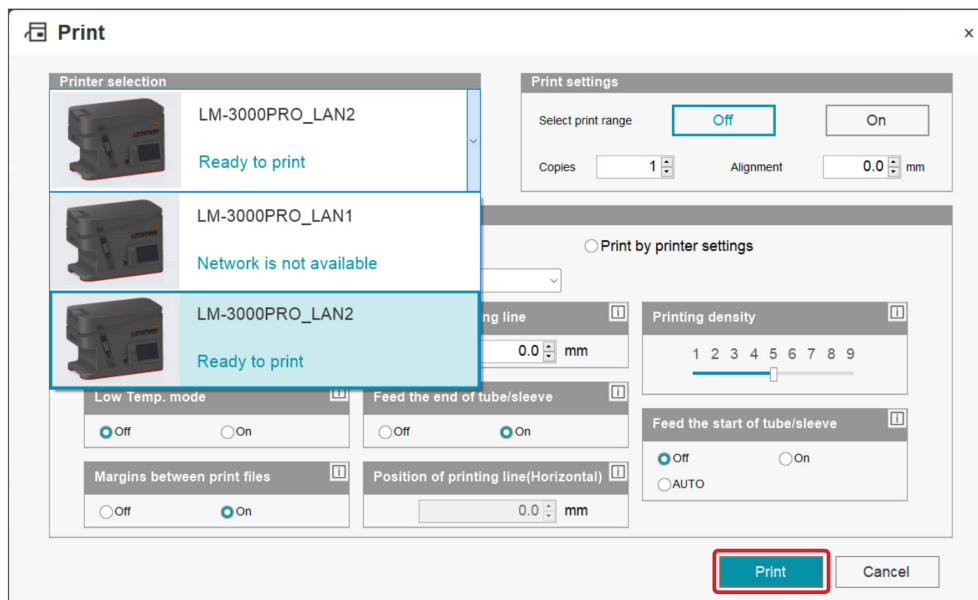

\* To print from the main unit, refer to 6-2 [→ 6-2 PRINTING](#)

# Chapter 8

## FUNCTIONS

---

<b>8-1 CHANGING THE PRINT FORMAT .....</b>	<b>108</b>
8-1-1 CHANGING THE NUMBER OF REPETITIONS .....	108
8-1-2 180° ROTATION PRINTING SETTINGS (GRIP SLEEVES AND TUBES ONLY) ....	109
8-1-3 INVERTED PRINTING.....	110
8-1-4 UNDERLINING .....	111
8-1-5 FRAMES .....	112
8-1-6 MAKING TABLES .....	113
8-1-7 CHANGING THE PITCH LENGTH.....	118
8-1-8 SORTING BY PITCH LENGTH .....	120
8-1-9 AUTOMATICALLY CHANGING THE PITCH LENGTH BASED ON CHARACTER COUNT .....	121
8-1-10 AUTOMATIC CHARACTER SIZE ADJUSTMENT .....	123
8-1-11 FIXING CHARACTER SIZE.....	125
8-1-12 HALF CUTTING/LINE AND DOT PRINTING BETWEEN PITCHES .....	127
8-1-13 VERTICAL AND HORIZONTAL TEXT SETTINGS .....	129
8-1-14 SETTING CHARACTER SPACING .....	131
8-1-15 SETTING LINE SPACING .....	133
8-1-16 CHANGING THE FONT .....	135
<b>8-2 ENHANCING CHARACTER RECOGNIZABILITY.....</b>	<b>137</b>
8-2-1 CHANGING PRINTING OF “6” AND “9” .....	137
8-2-2 ADDING SLASHES TO ZEROS (“0”).....	139
8-2-3 BATCH ADDITION OF PERIODS AFTER TEXT .....	141
8-2-4 USING CLEAR FONT .....	142
<b>8-3 SETTING THE PRINT MODE AT LOW TEMPERATURES .....</b>	<b>143</b>
8-3-1 USING THE TUBE HEATER.....	143
8-3-2 LOWERING THE PRINT SPEED.....	144
8-3-3 ADJUSTING THE PRINTING DENSITY .....	145
<b>8-4 SETTING SEQUENCES.....</b>	<b>146</b>
8-4-1 SETTING SEQUENCES.....	146
8-4-2 SETTING THE ORDER FOR PRINTING SEQUENCES.....	149
<b>8-5 ENTERING SYMBOLS AND TEXT WITH DIACRITICS.....</b>	<b>150</b>
8-5-1 ENTERING ELECTRICAL INSTALLATION SYMBOLS.....	150
8-5-2 ENTERING SYMBOLS AND TEXT WITH DIACRITICS.....	153

**8-6 CHECKING PREVIEWS..... 155**  
 8-6-1 VIEWING INDIVIDUAL PREVIEWS.....155  
 8-6-2 FULL PREVIEW .....156

**8-7 BATCH EDITING OF SETTING VALUES (CHARACTER SIZE, CHARACTER WIDTH, REPEAT, PITCH LENGTH, UNDERLINE, INVERT, 180° ROTATION PRINT) ..... 157**  
 8-7-1 BATCH CHANGES FROM THE EDIT MENU.....157  
 8-7-2 DOUBLE CLICKING TO BATCH CHANGE ITEMS IN LETATWIN PC EDITOR PRO.....159

**8-8 ADVANCED PRINT SETTINGS ..... 160**  
 8-8-1 SELECTING THE MODEL TO PRINT .....160  
 8-8-2 SELECTING THE PRINT RANGE .....161  
 8-8-3 SELECTING THE NUMBER OF PRINT COPIES .....163  
 8-8-4 PRINT ALIGNMENT.....164  
 8-8-5 SEPRATING MAIN PRINTER UNIT AND LETATWIN PC EDITOR PRO SETTINGS AND PRINTING FROM LETATWIN PC EDITOR PRO .....165  
 8-8-6 SETTING THE CUTTING POSITION .....167  
 8-8-7 SETTING THE PRINTING LINE POSITION.....168  
 8-8-8 SETTING POST-PRINT FEEDING.....169  
 8-8-9 PRE-PRINT FEEDING .....171  
 8-8-10 SETTING MARGINS BETWEEN PRINT FILES .....172  
 8-8-11 ADJUSTING THE HORIZONTAL PRINTING LINE POSITION (BLOCK MARKERS ONLY).....173  
 8-8-12 SWITCHING DISPLAYED UNITS BETWEEN MILIMETERS AND INCHES .....174

**8-9 REGISTERING DEFAULT SETTINGS (INITIAL VALUES)..... 175**  
 8-9-1 REGISTERING BASIC SETTINGS.....176  
 8-9-2 REGISTERING PRINT SETTINGS .....176  
 8-9-3 REGISTERING PRINT PARAMETER SETTINGS.....177

**8-10 SAVING AND SENDING FILES..... 179**  
 8-10-1 SAVING FILES WITH A NEW NAME .....179  
 8-10-2 SAVING FILES BY OVERWRITING.....181  
 8-10-3 SENDING FILES.....182  
 8-10-4 RECORDING COMMENTS IN FILES .....183

**8-11 DOUBLE-SIDED PRINTING ..... 185**

# 8-1 CHANGING THE PRINT FORMAT

## 8-1-1 CHANGING THE NUMBER OF REPETITIONS

The number of units to be printed repeatedly can be set for each block, within a range of 1 to 300.

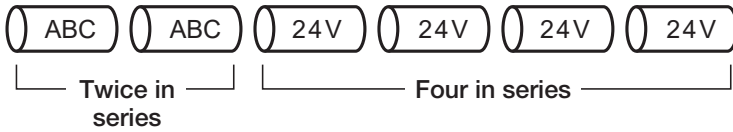

**1** Double click on the “Repeat” input field and enter a value.

**MAX LETATWIN PC EDITOR PRO**

File(F) Edit(E) Block Help

New Open Save Send Print Preview Undo Redo Cut Copy Paste text Paste format Sequence Frame Symbol Diacritical mark Cell merging Delete End plate Sort-pitch length Default settings

LMPC1 X

2 - Line 1 24V

	Line 1	Line 2	Line 3	Line 4	Repeat	Pitch length	Underline	Invert	180° rotation print
1	ABC				2 pcs	20.0 mm	Off	Off	Off
2	24V				4 pcs	20.0 mm	Off	Off	Off
3									
4									
5									
6									
7									
8									
9									

### MEMO

- The default value for repeats can be set for each type of print material by accessing “Default settings”-“Basic settings”- “Repeat.”  
→ 8-9 REGISTERING DEFAULT SETTINGS (INITIAL VALUES)
- The number of repeats can be changed for all blocks at once.  
→ 8-7 BATCH EDITING OF SETTING VALUES (CHARACTER SIZE, CHARACTER WIDTH, REPEAT, PITCH LENGTH, UNDERLINE, INVERT, 180° ROTATION PRINT)
- When printing multiple copies of entire input documents, set the number of copies from “Print” - “Print settings” before printing.

## 8-1-2 180° ROTATION PRINTING SETTINGS (GRIP SLEEVES AND TUBES ONLY)

Blocks are printed in pairs, with one or both being rotated 180°.

Four patterns can be selected “OFF,” “Rotate front only,” “Rotate rear only” and “Rotate all.”



**1** Select the rotation pattern from “180° rotation print.”

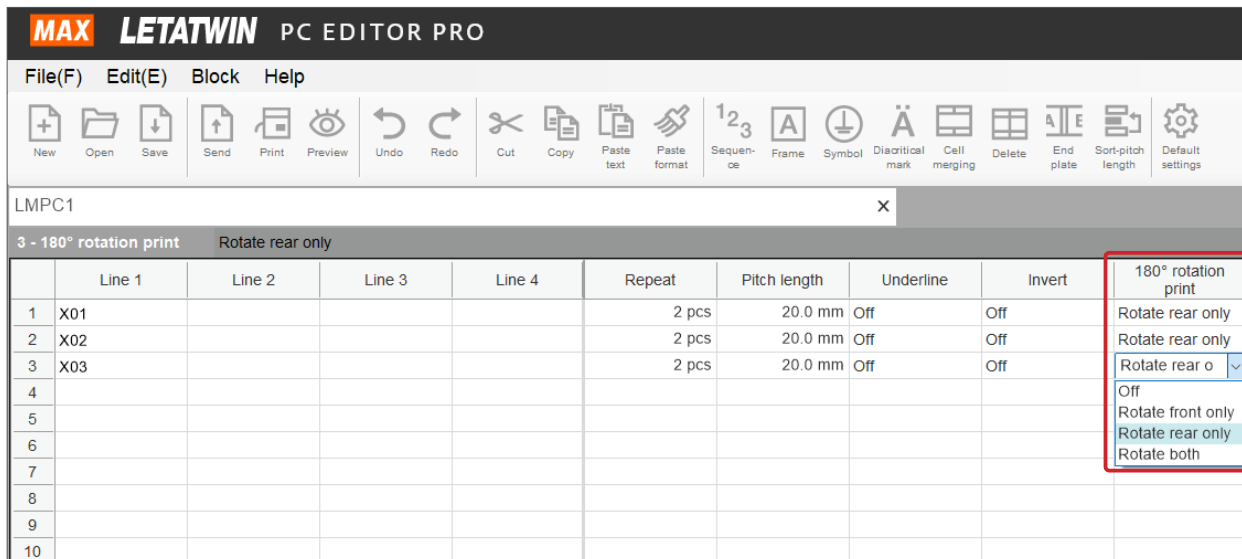

**MEMO**

- 180° rotation print can only be set for grip sleeves and tubes. It cannot be set for other print materials.
- This can only be set for blocks for which the repeat count is one or an even number.
- The method for setting 180° rotation print varies depending on the model.

	180° rotation print	Setting range	Rotation method	Settings screen	Input restrictions for repeats
LM-3000	○	Per block	Front only/Rear only/Both	Main editing screen	Even numbers only
*LM-550A3/550A2	○	Whole document	Rear only	Print screen	None
LM-550A	×				

**CAUTION**

On the LM-550A3/550A2, items for which 180° rotation print has been set are duplicated automatically, meaning the quantity printed is doubled. Set the number of repetitions to half of the desired amount before printing.

## 8-1-3 INVERTED PRINTING

During inverted printing, the print area is filled in and the entered characters are printed as cutout text.



### 1 Set "Invert" to "ON."

**MAX LETATWIN PC EDITOR PRO**

File(F) Edit(E) Block Help

New Open Save Send Print Preview Undo Redo Cut Copy Paste text Paste format Sequence Frame Symbol Diacritical mark Cell merging Delete End plate Sort-pitch length Default settings

LMPC1 X

1 - Invert On

	Line 1	Line 2	Line 3	Line 4	Repeat	Pitch length	Underline	Invert	180° rotation print
1	CG				2 pcs	20.0 mm	Off	On	Off
2								Off	
3								On	
4								Off	
5								On	
6								Off	
7								On	
8								Off	
9								On	
10								Off	

#### MEMO

- Inverted printing can be set for each block.
- Inverted printing can be applied to entire documents as a batch.  
 → 8-7 BATCH EDITING OF SETTING VALUES (CHARACTER SIZE, CHARACTER WIDTH, REPEAT, PITCH LENGTH, UNDERLINE, INVERT, 180° ROTATION PRINT)
- Inverted printing can lead to text defects due to factors such as ink ribbons sticking to printed material.  
 In such cases, reducing the printing density setting is recommended.

→ 6-9-1 SETTING THE PRINTING DENSITY

## 8-1-4 UNDERLINING

Underline settings can be set for each block.

COM COM X01 X01

**1** Set “Underline” to “ON.”

	Line 1	Line 2	Line 3	Line 4	Repeat	Pitch length	Underline	Invert	180° rotation print
1	COM				2 pcs	20.0 mm	Off	Off	Off
2	X01				2 pcs	20.0 mm	On	Off	Off
3							Off		
4							Off		
5							Off		
6							Off		
7							Off		
8							Off		
9							Off		
10							Off		
11							Off		
12							Off		

### MEMO

- Underline settings can be set for entire documents as a batch.
- 8-7 BATCH EDITING OF SETTING VALUES (CHARACTER SIZE, CHARACTER WIDTH, REPEAT, PITCH LENGTH, UNDERLINE, INVERT, 180° ROTATION PRINT)
- While underline settings can be set for each block, it is not possible to underline only specific characters within a block.
- Underlining cannot be printed when a frame or inversion has been set.

## 8-1-5 FRAMES

Set a frame for all documents.

Click on the frame icon or apply settings using the “Frame” field in the “Print settings” screen.

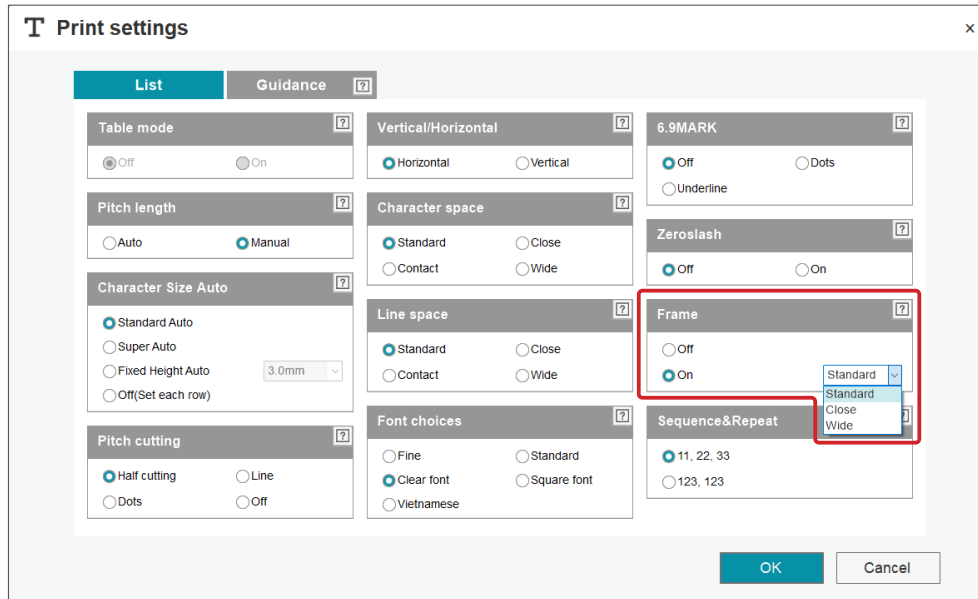

### MEMO

- Three frame sizes can be chosen through “Print settings.” (Close, Standard or Wide.)

None  Close  Standard  Wide

- Settings cannot be applied to individual blocks.
- Settings cannot be applied to only specific characters within a block.

## 8-1-6 MAKING TABLES

Tables can be made for marker strips and tape only. They cannot be made for other print material.

1	2	3	4	5
A	B	C	D	E

**1** In LETATWIN PC EDITOR PRO select “File” - “Print settings.”

To display the print settings screen, access “File” ⇒ “Print settings” from the main editing screen or click on  button next to “Print settings” on the right hand side of the screen.

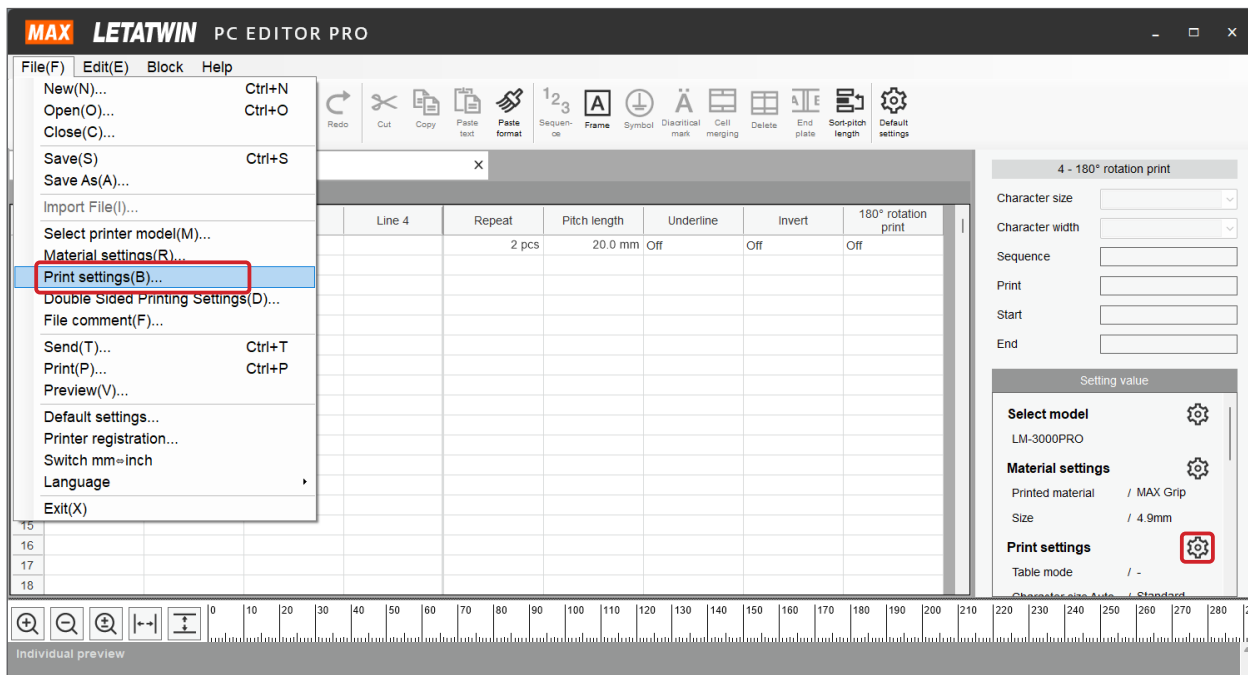

**2** Set “Table mode” to “ON,” then click the “OK” button.

When “Table mode” is set to “ON,” lines appear between blocks and lines.

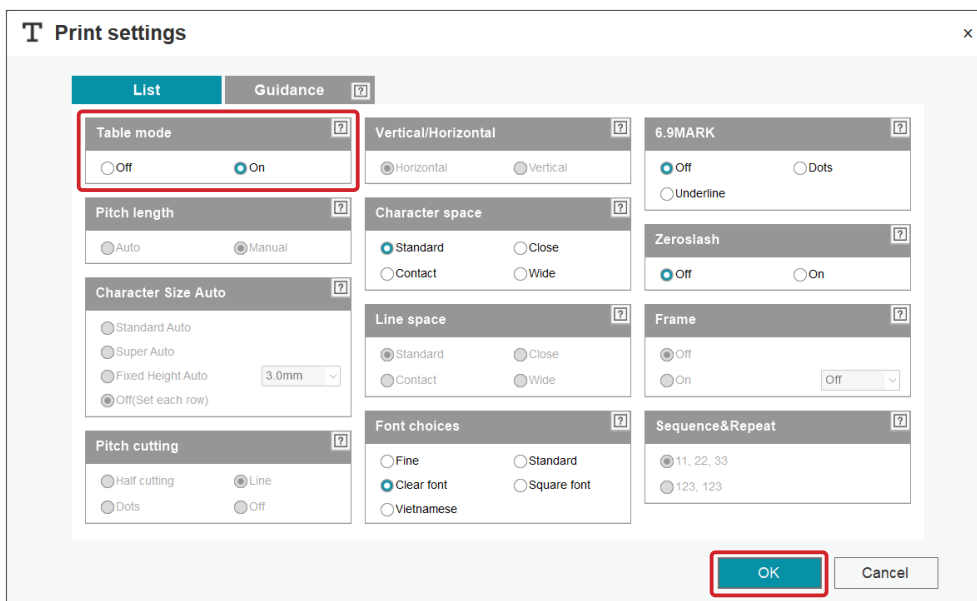

**3** Setting can also be performed from the guidance screen.

**T Print settings** x

List
Guidance ?

**Table mode**

Pitch length

Character Size Auto

Pitch cutting

Vertical/Horizontal

Character space

Line space

Font choices

6.9MARK

Zeroslash

Frame

Sequence&Repeat

**Table mode** You can only select when "Tape" or "Marker strip" is selected.

On : 1. Insert line 2. Cell merging 3. Insert end plate

Off

	Line 1	Line 2	Line 3
1	A1	1	
2	A2	2	
3	A3	3	

On

1.

	Line 1	Line 2	Line 3
1	A1	1	
2	A2	2	
3	A3	3	

2.

	Line 1	Line 2	Line 3
1	24V DC	M1	1
2		M2	2
3			3

3.

	Line 1	Line 2	Line 3
1	A1	1	
2			
3	A2	2	

OK
Cancel

## Merging cells

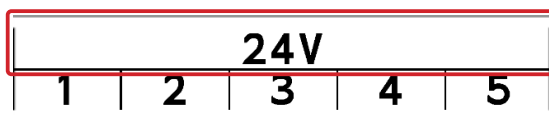

- 1 Select the cells to be merged, then click the  icon.

**MAX LETATWIN PC EDITOR PRO**

File(F) Edit(E) Block Help

New Open Save Send Print Preview Undo Redo Cut Copy Paste text Paste format Sequence Frame Symbol Discritical mark **Cell merging** Delete End plate Sort-pitch length Default settings

LMPC1 X

1 - Line 1 24V

	Line 1	Line 2	Line 3	Line 4	Repeat	Pitch length	Underline	Invert	180° rotation print
1	24V	1			1 pcs	10.0 mm	Off	Off	Off
2		2			1 pcs	10.0 mm	Off	Off	Off
3		3			1 pcs	10.0 mm	Off	Off	Off
4		4			1 pcs	10.0 mm	Off	Off	Off
5		5			1 pcs	10.0 mm	Off	Off	Off
6									
7									
8									
9									
10									

- 2 The cells are merged.

**MAX LETATWIN PC EDITOR PRO**

File(F) Edit(E) Block Help

New Open Save Send Print Preview Undo Redo Cut Copy Paste text Paste format Sequence Frame Symbol Discritical mark Cell merging Delete End plate Sort-pitch length Default settings

LMPC1 X

1 - Line 1 24V

	Line 1	Line 2	Line 3	Line 4	Repeat	Pitch length	Underline	Invert	180° rotation print
1	24V	1			1 pcs	10.0 mm	Off	Off	Off
2		2			1 pcs	10.0 mm	Off	Off	Off
3		3			1 pcs	10.0 mm	Off	Off	Off
4		4			1 pcs	10.0 mm	Off	Off	Off
5		5			1 pcs	10.0 mm	Off	Off	Off
6									
7									
8									
9									
10									
11									
12									
13									
14									

## End plate (space) settings

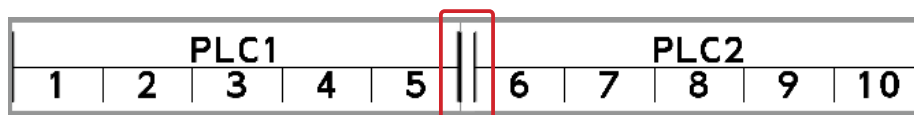

- 1 Select the blocks to set an end plate for, then click the  icon.

**MAX LETATWIN PC EDITOR PRO**

File(F) Edit(E) Block Help

New Open Save Send Print Preview Undo Redo Cut Copy Paste text Paste format Sequence Frame Symbol Diacritical mark Cell merging Delete **End plate** Sort-pitch length Default settings

LMPC1 X

6 - Line 1

	Line 1	Line 2	Line 3	Line 4	Repeat	Pitch length	Underline	Invert	180° rotation print
1	PLC1	1			1 pcs	10.0 mm	Off	Off	Off
2		2			1 pcs	10.0 mm	Off	Off	Off
3		3			1 pcs	10.0 mm	Off	Off	Off
4		4			1 pcs	10.0 mm	Off	Off	Off
5		5			1 pcs	10.0 mm	Off	Off	Off
6					1 pcs	10.0 mm	Off	Off	Off
7	PLC2	6			1 pcs	10.0 mm	Off	Off	Off
8		7			1 pcs	10.0 mm	Off	Off	Off
9		8			1 pcs	10.0 mm	Off	Off	Off
10		9			1 pcs	10.0 mm	Off	Off	Off
11		10			1 pcs	10.0 mm	Off	Off	Off
12									

- 2 An end plate is set.

**MAX LETATWIN PC EDITOR PRO**

File(F) Edit(E) Block Help

New Open Save Send Print Preview Undo Redo Cut Copy Paste text Paste format Sequence Frame Symbol Diacritical mark Cell merging Delete **End plate** Sort-pitch length Default settings

LMPC1 X

6 - Line 1

	Line 1	Line 2	Line 3	Line 4	Repeat	Pitch length	Underline	Invert	180° rotation print
1	PLC1	1			1 pcs	10.0 mm	Off	Off	Off
2		2			1 pcs	10.0 mm	Off	Off	Off
3		3			1 pcs	10.0 mm	Off	Off	Off
4		4			1 pcs	10.0 mm	Off	Off	Off
5		5			1 pcs	10.0 mm	Off	Off	Off
6					1 pcs	1.5 mm	Off	Off	Off
7	PLC2	6			1 pcs	10.0 mm	Off	Off	Off
8		7			1 pcs	10.0 mm	Off	Off	Off
9		8			1 pcs	10.0 mm	Off	Off	Off
10		9			1 pcs	10.0 mm	Off	Off	Off
11		10			1 pcs	10.0 mm	Off	Off	Off
12									
13									
14									

## MEMO

- Up to three lines can be created in table mode.
- The full tables can be viewed using "Full preview."
- Text cannot be entered for blocks for which an end plate has been set.
- The end plate pitch length can be set between 1.0 and 5.0mm. End plates cannot be set for blocks that have been merged.
- Creation may not be possible for some combinations of merged cells.
- Printing cannot be performed while errors displayed in orange are present.
- Cells cannot be merged if the pitch length of the preceding block has not been set. Enter the pitch length before merging cells.
- If a "Print height over" error message appears, please reduce the font height of the target cell.
- Examples of merging

→ 12-1 LETATWIN PC EDITOR PRO DISPLAY CREATION DETAILS

## 8-1-7 CHANGING THE PITCH LENGTH

The pitch length can be changed for each block or as a batch.

→ 8-7 BATCH EDITING OF SETTING VALUES (CHARACTER SIZE, CHARACTER WIDTH, REPEAT, PITCH LENGTH, UNDERLINE, INVERT, 180° ROTATION PRINT)

Setting different pitch lengths for each block:

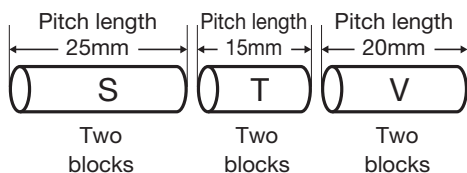

**1** Double click on the “Pitch length” field for the block to be changed, then enter “15.0.”

**MAX LETATWIN PC EDITOR PRO**

File(F) Edit(E) Block Help

New Open Save Send Print Preview Undo Redo Cut Copy Paste text Paste format Sequence Frame Symbol Diacritical mark Cell merging Delete End plate Sort-pitch length Default settings

LMPC1

15 - Repeat

	Line 1	Line 2	Line 3	Line 4	Repeat	Pitch length	Underline	Invert	180° rotation print
1	S				2 pcs	25.0 mm	Off	Off	Off
2	T				2 pcs	15.0 mm	Off	Off	Off
3	V				2 pcs	25.0 mm	Off	Off	Off
4									

**2** Only the pitch length for the desired block is changed.

**MAX LETATWIN PC EDITOR PRO**

File(F) Edit(E) Block Help

New Open Save Send Print Preview Undo Redo Cut Copy Paste text Paste format Sequence Frame Symbol Diacritical mark Cell merging Delete End plate Sort-pitch length Default settings

LMPC1

2 - Pitch length 15.0

	Line 1	Line 2	Line 3	Line 4	Repeat	Pitch length	Underline	Invert	180° rotation print
1	S				2 pcs	25.0 mm	Off	Off	Off
2	T				2 pcs	15.0 mm	Off	Off	Off
3	V				2 pcs	25.0 mm	Off	Off	Off
4									

•Allowable pitch length settings (mm) by model and material

	LM-3000PRO	LM-550A3	LM-550A2	LM-550A
MAX grip sleeve	10.0 to 150.0			
MAX grip tube	10.0 to 150.0	10.0 to 150.0	10.0 to 150.0	
MAX tube	10.0 to 150.0	10.0 to 150.0	10.0 to 150.0	10.0 to 60.0
Shrinkable tubes	5.0 to 500.0	10.0 to 150.0	10.0 to 150.0	10.0 to 60.0
Generic tubes	10.0 to 150.0	10.0 to 150.0	10.0 to 150.0	10.0 to 60.0
MAX ID plates	4.0 to 60.0	4.0 to 60.0	4.0 to 60.0	4.0 to 60.0
MAX tape	3.5 to 60.0	3.5 to 60.0	3.5 to 60.0	4.0 to 60.0
MAX marking plate	2.5 to 60.0			
Generic marker strips	2.5 to 60.0			
Block markers	Setting cannot be changed			



- The initial pitch length value for each material can be set under “Default settings” - “Pitch length.”

The number of times that the pitch length can be changed for each model is as follows.

Model name	Allowable number of pitch length changes
LM-3000PRO	2000
LM-550A3/550A2	999
LM-550A	5

## 8-1-8 SORTING BY PITCH LENGTH

- 1 Click on the  icon.

The same operation can be performed using “Edit”- “Sort by pitch length.”

**MAX LETATWIN PC EDITOR PRO**

File(F) Edit(E) Block Help

New Open Save Send Print Preview Undo Redo Cut Copy Paste text Paste format Sequence Frame Symbol Diacritical mark Cell merging Delete End plate **Sort-pitch length** Default settings

LMPC1 X

11 - Line 1

	Line 1	Line 2	Line 3	Line 4	Repeat	Pitch length	Underline	Invert	180° rotation print
1	X01				2 pcs	20.0 mm	Off	Off	Off
2	X02				2 pcs	20.0 mm	Off	Off	Off
3	X03				2 pcs	20.0 mm	Off	Off	Off
4	COM				2 pcs	15.0 mm	Off	Off	Off
5	COM				2 pcs	15.0 mm	Off	Off	Off
6	X04				2 pcs	20.0 mm	Off	Off	Off
7	X05				2 pcs	20.0 mm	Off	Off	Off
8	X06				2 pcs	20.0 mm	Off	Off	Off
9	COM				2 pcs	15.0 mm	Off	Off	Off
10	COM				2 pcs	15.0 mm	Off	Off	Off

- 2 The pitch lengths are sorted.

**MAX LETATWIN PC EDITOR PRO**

File(F) Edit(E) Block Help

New Open Save Send Print Preview Undo Redo Cut Copy Paste text Paste format Sequence Frame Symbol Diacritical mark Cell merging Delete End plate Sort-pitch length Default settings

LMPC1 X

11 - Line 1

	Line 1	Line 2	Line 3	Line 4	Repeat	Pitch length	Underline	Invert	180° rotation print
1	X01				2 pcs	20.0 mm	Off	Off	Off
2	X02				2 pcs	20.0 mm	Off	Off	Off
3	X03				2 pcs	20.0 mm	Off	Off	Off
4	X04				2 pcs	20.0 mm	Off	Off	Off
5	X05				2 pcs	20.0 mm	Off	Off	Off
6	X06				2 pcs	20.0 mm	Off	Off	Off
7	COM				2 pcs	15.0 mm	Off	Off	Off
8	COM				2 pcs	15.0 mm	Off	Off	Off
9	COM				2 pcs	15.0 mm	Off	Off	Off
10	COM				2 pcs	15.0 mm	Off	Off	Off

## 8-1-9 AUTOMATICALLY CHANGING THE PITCH LENGTH BASED ON CHARACTER COUNT

Pitch Length Auto is a function that automatically adjusts the pitch length based on the number of characters entered.

It is applied to entire documents and cannot be set separately for each block.

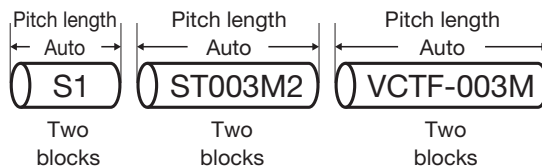

- 1 To display the print settings screen, access “File” ⇒ “Print settings” from the main editing screen or click on  button next to “Print settings” on the right hand side of the screen.

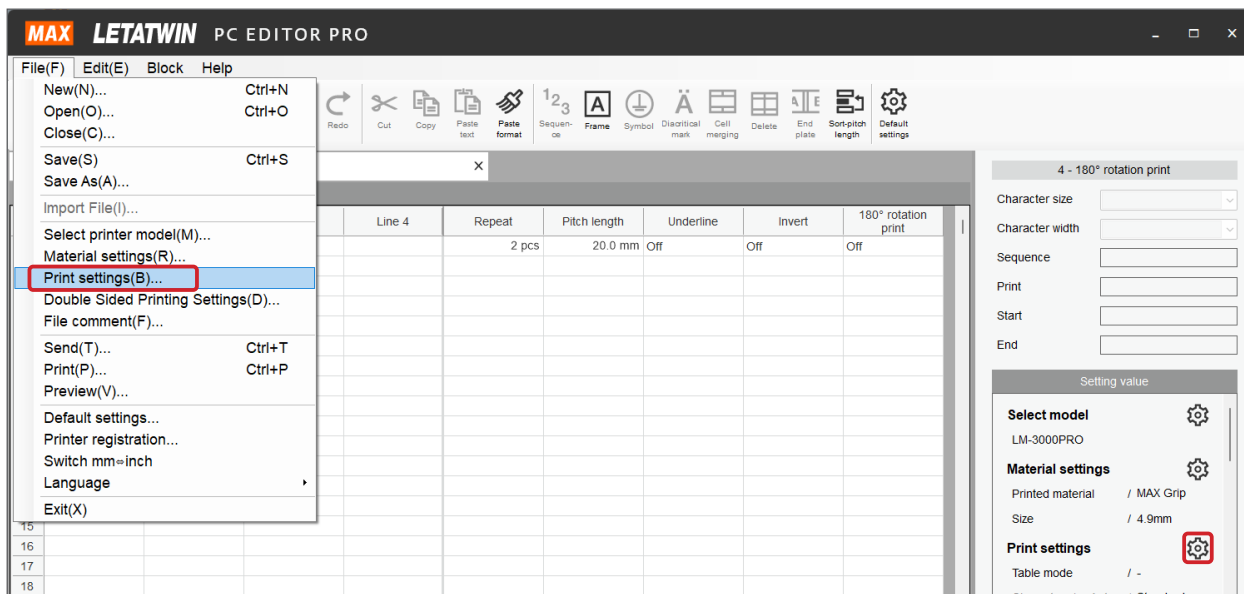

- 2** Set “Pitch length” to “Auto” and set “Character Size Auto” to “OFF,” then click OK.  
Clicking on the  button displays on-screen guidance.

**MEMO**

- The Pitch Length Auto function and the Character Size Auto function cannot be used simultaneously.  
Set “Character Size Auto” to “OFF” when using the Pitch Length Auto function.

**T Print settings** x







List Guidance 

Table mode   Off  On

Pitch length   Auto  Manual

Character Size Auto   Standard Auto  
 Super Auto  
 Fixed Height Auto 3.0mm   
 Off(Set each row)

Pitch cutting   Half cutting  Line  
 Dots  Off

Vertical/Horizontal   Horizontal  Vertical

Character space   Standard  Close  
 Contact  Wide

Line space   Standard  Close  
 Contact  Wide

Font choices   Fine  Standard  
 Clear font  Square font  
 Vietnamese

6.9MARK   Off  Dots  
 Underline

Zeroslash   Off  On

Frame   Off  On Standard

Sequence&Repeat   11, 22, 33  
 123, 123

**OK** Cancel

**T Print settings** x

List Guidance 

Table mode

**Pitch length**

Character Size Auto

Pitch cutting

Vertical/Horizontal

Character space

Line space

Font choices

6.9MARK

Zeroslash

Frame

Sequence&Repeat

Pitch length When set to auto, the pitch length changes according to the number of characters.  
\*Please enter the pitch length in the "Pitch Length" cell on the main editing screen.

Auto **AAA** **BBBBBB**

Manual **AAA** **BBBBBB**

**OK** Cancel

**MEMO**

- When Pitch Length Auto is set, the minimum pitch length for each print material type is applied as the minimum pitch length.

→ 8-1-7 CHANGING THE PITCH LENGTH

## 8-1-10 AUTOMATIC CHARACTER SIZE ADJUSTMENT

The Character Size Auto function changes the character height, character width, character spacing and line spacing based on the number of characters entered. Character Size Auto can be set to four options.

	Character height	Character width	Character spacing/ Line spacing
Standard Auto	Automatic adjustment	Automatic adjustment	Close
Super Auto	Automatic adjustment	Automatic adjustment	Automatic adjustment
Wide Auto	Fixed (manual)	Automatic adjustment	Automatic adjustment
OFF	Fixed (manual)	Fixed (manual)	Fixed (manual)

The initial setting is “Standard Auto,” meaning the character height is automatically optimized based on the size of the print material and the pitch length. The character heights that can be set are as follows.

6.0mm	24V	3.0mm	24V	2.0mm	24V
4.0mm	24V	2.4mm (Alphanumeric characters and some symbols only)	24V	1.3mm	24V

1

“Character Size Auto” settings can be adjusted from the “Print settings” screen.

To display the “Print settings” screen, access “File” ⇒ “Print settings” from the main editing screen or click on  button next to “Print settings” on the right hand side of the screen.

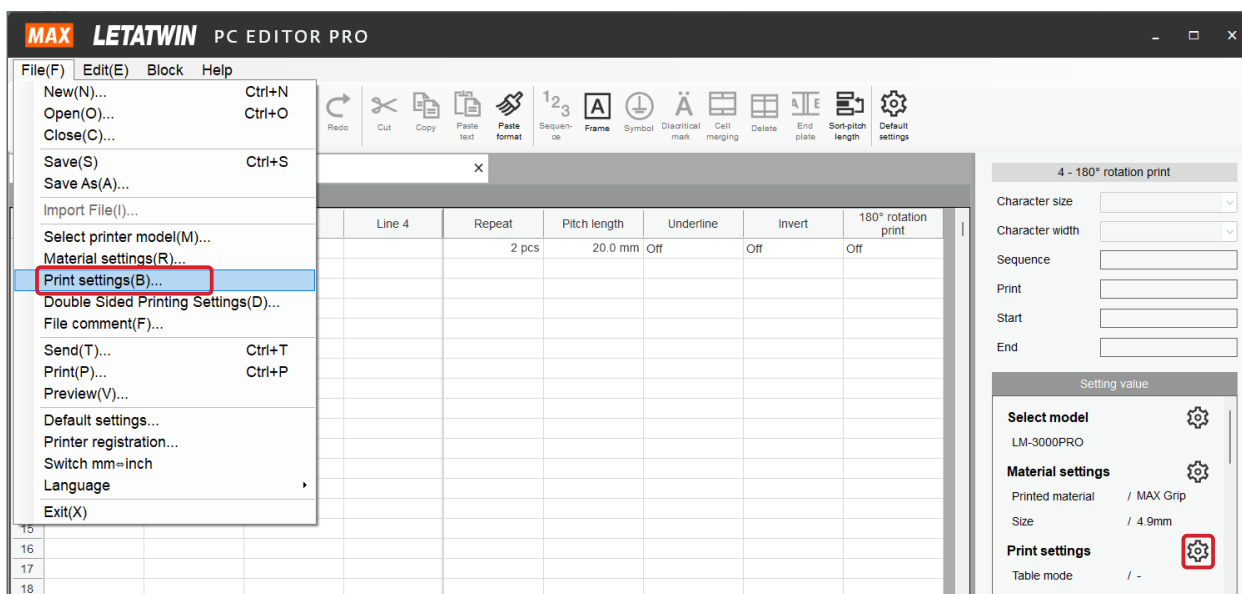

- 2** Select a Character Size Auto type from the “Print settings” - “Character Size Auto” field, then click “OK.”

The screenshot shows the 'Print settings' dialog box with the 'List' tab selected. The 'Character Size Auto' section is highlighted with a red box. It contains the following options:

- Standard Auto
- Super Auto
- Fixed Height Auto (3.0mm)
- Off (Set each row)

The 'OK' button at the bottom right is also highlighted with a red box.

### MEMO

- For blocks with the “Character height” set to 2.4mm, if a line includes characters other than alphanumeric characters and some symbols (hiragana, katakana or kanji), all text in that line is printed at 2.0mm.
- Pitch length: When pitch length is set to “Auto,” character size cannot be set to “Auto.”
- List of symbols that can be used at 2.4mm

!	Exclamation mark	/	Slash
?	Question mark	*	Asterisk
#	Hash	+	Plus sign
(	Left bracket	-	Minus sign
)	Right bracket		Space
~	Tilde	,	Comma
=	Equals sign	.	Dot

- Auto function (Standard Auto, Super Auto, Wide Auto and OFF) can be applied as default settings. → [8-9 REGISTERING DEFAULT SETTINGS \(INITIAL VALUES\)](#)

\*The LM-550A cannot use the Super Auto and Fixed Height Auto functions.

## 8-1-11 FIXING CHARACTER SIZE

During use with a fixed character size (height), set “Character Size Auto” to “OFF.”

**1** “Character Size Auto” - “OFF” can be set from the “Print settings” screen.

To display the “Print settings” screen, access “File” ⇒ “Print settings” from the main editing screen or click on  button next to “Print settings” on the right hand side of the screen.

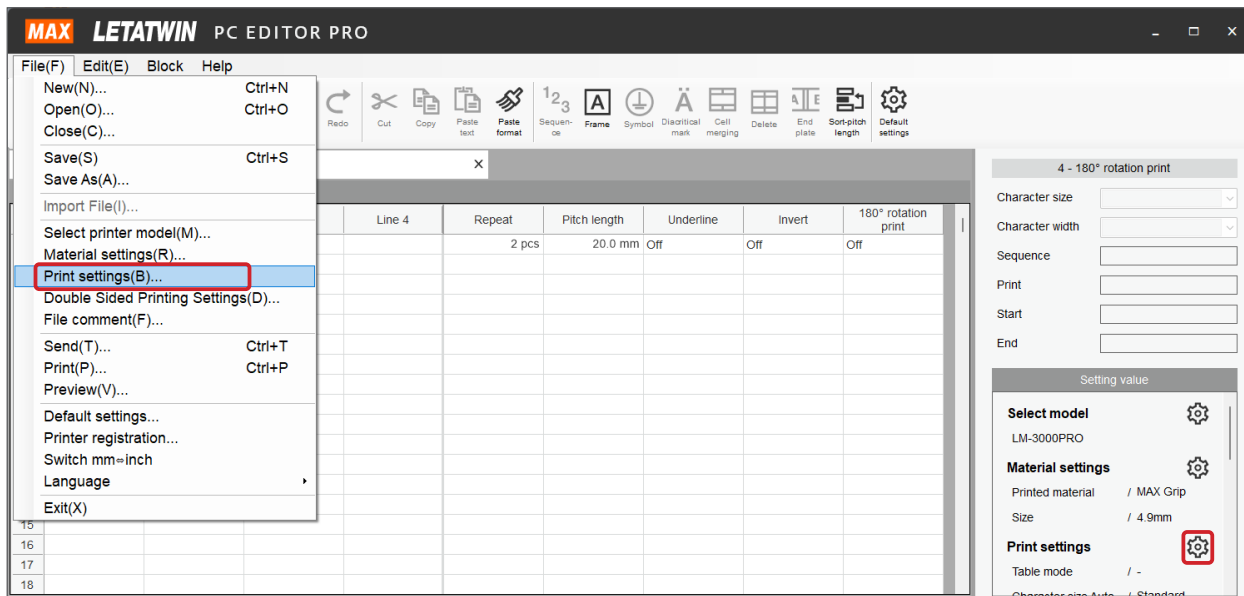

**2** In the “Print settings” - “Character Size Auto” field, select “OFF,” then click “OK.”

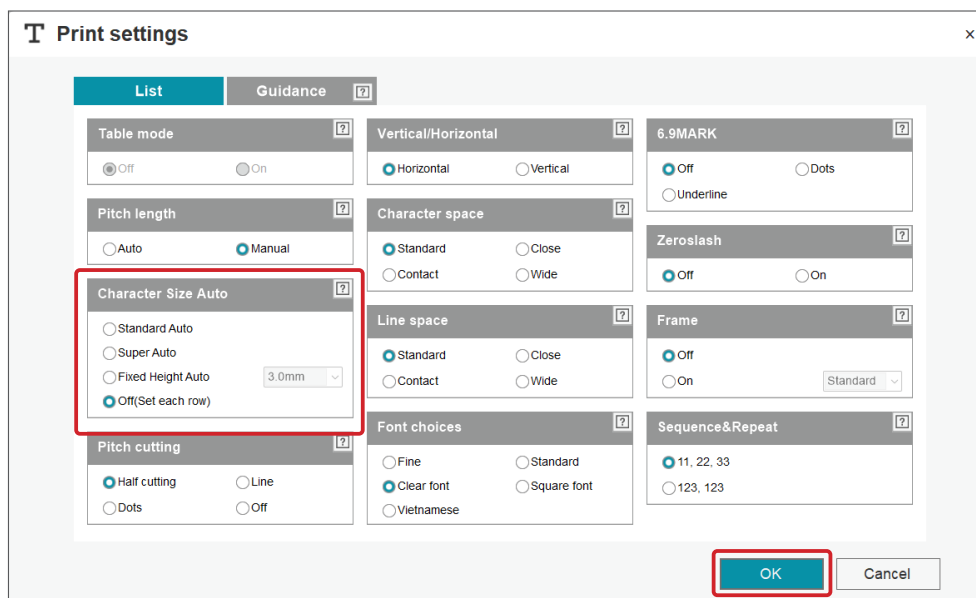

### 3 Character size can be set for each block.

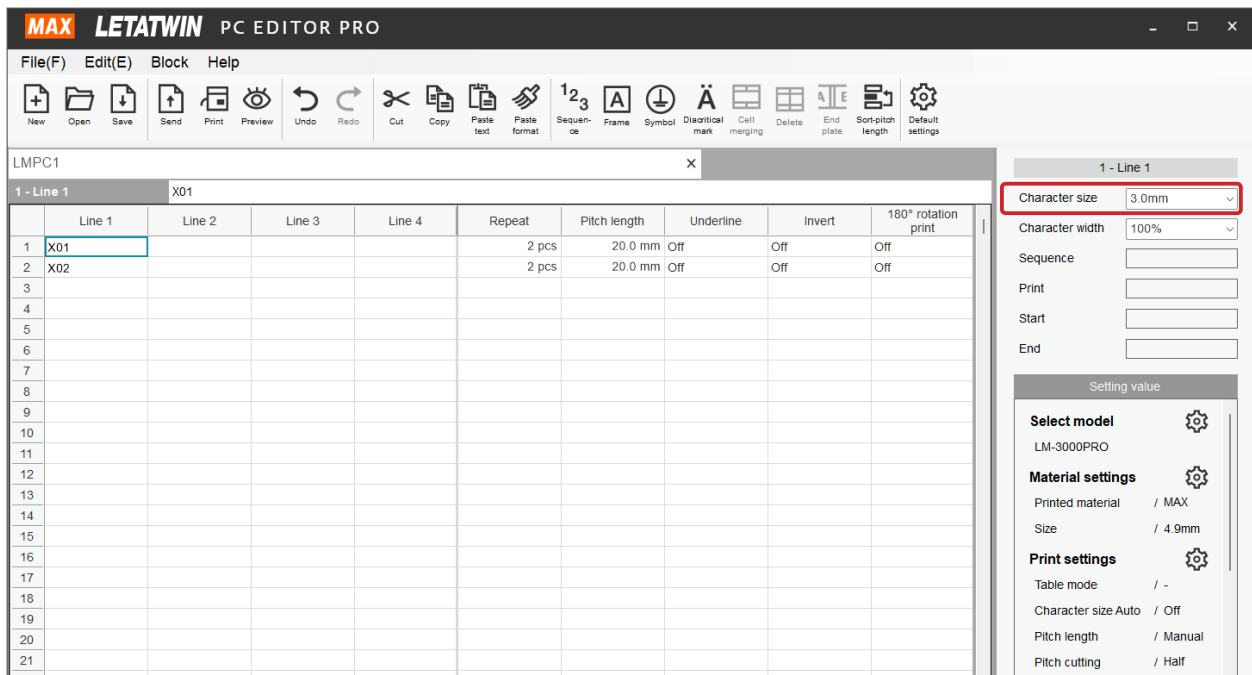

#### MEMO

- When Character Size Auto is “OFF,” an error message may be displayed if the print height exceeds the print material size or pitch length. If this occurs, reduce the character height.
- Character size can be set for all blocks at once. z  
 → 8-7 BATCH EDITING OF SETTING VALUES (CHARACTER SIZE, CHARACTER WIDTH, REPEAT, PITCH LENGTH, UNDERLINE, INVERT, 180° ROTATION PRINT)
- Character Size Auto settings can be registered as initial values.  
 → 8-9 REGISTERING DEFAULT SETTINGS (INITIAL VALUES)
- Fixed Height Auto uses a fixed character height and automatically adjusts the character width based on the number of characters.

## 8-1-12 HALF CUTTING/LINE AND DOT PRINTING BETWEEN PITCHES

The following four options can be selected for cutting and print formatting between pitches.

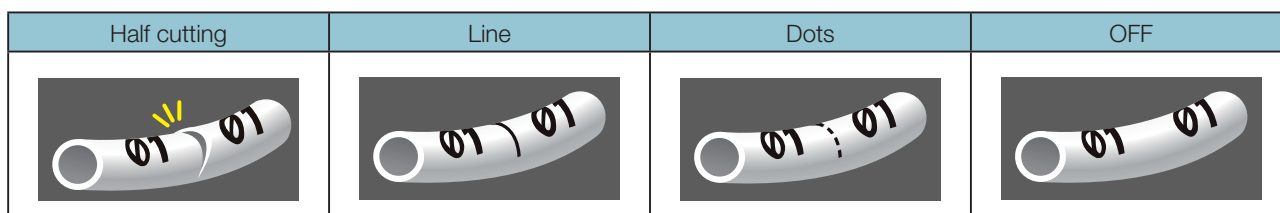

The available settings for each model are as follows.

Print material	LM-3000PRO	LM-550A3/550A2/550A
MAX grip sleeve	Half cutting / Line / Dots / None	
MAX tubes (up to ø6.4)	Half cutting / Line / Dots / None	Half cutting / Line / Dots / None
MAX tubes (ø8.0)	Half cutting / Line / Dots / None	Half cutting / Line / Dots / None
Other tubes (up to ø6.4)	Half cutting / Line / Dots / None	Half cutting / Line / Dots / None
Other tubes (ø8.0)	Half cutting / Line / Dots / None	Line / Dots / None
Other tubes (ø10)	Half cutting / Line / Dots / None	
Tape	Half cutting / Line / Dots / None	Half cutting / Line / Dots / None
Marker strips	Half cutting / Line / Dots / None	Half cutting / Line / Dots / None
Block markers	Setting cannot be changed	
ID Plate	Half cutting / Line / Dots / None	Half cutting / Line / Dots / None

**1** Settings for cutting and print formatting between pitches can be adjusted on the “Print settings” screen.

To display the “Print settings” screen, access “File” ⇒ “Print settings” from the main editing screen or click on  next to “Print settings” on the right hand side of the screen.

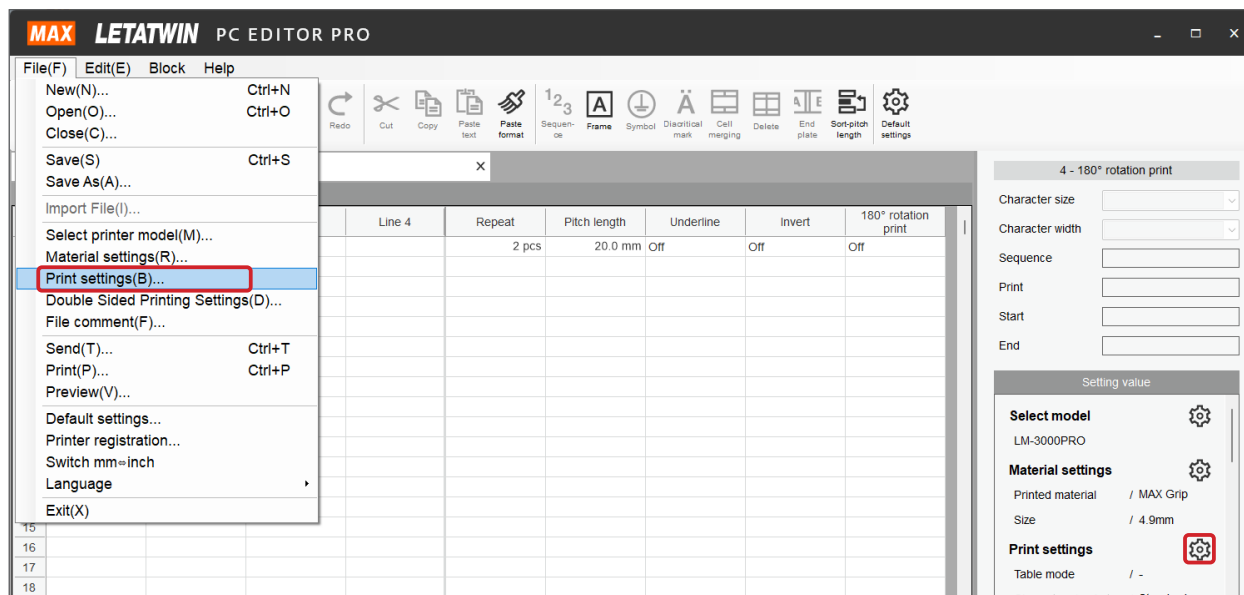

- 2 Select the desired type from the “Print settings” - “Pitch cutting” field, then click “OK.”

The screenshot shows the 'Print settings' dialog box with the following sections:

- Table mode:**  Off,  On
- Pitch length:**  Auto,  Manual
- Character Size Auto:**  Standard Auto,  Super Auto,  Fixed Height Auto (3.0mm),  Off(Set each row)
- Pitch cutting:**  Half cutting,  Line,  Dots,  Off
- Vertical/Horizontal:**  Horizontal,  Vertical
- Character space:**  Standard,  Close,  Contact,  Wide
- Line space:**  Standard,  Close,  Contact,  Wide
- Font choices:**  Fine,  Standard,  Clear font,  Square font,  Vietnamese
- 6.9MARK:**  Off,  Dots,  Underline
- Zeroslash:**  Off,  On
- Frame:**  Off,  On, Standard (dropdown)
- Sequence&Repeat:**  11, 22, 33,  123, 123

Buttons: **OK** (highlighted), **Cancel**

**MEMO**

- Settings for cutting and print formatting between pitches can be registered as initial values.  
→ 8-9 REGISTERING DEFAULT SETTINGS (INITIAL VALUES)
- The LM-550A3/550A2/550A cannot perform half cutting on non-MAX tubes thicker than  $\phi 6.5$ .
- Harf cutting cannot be set for block markers, marker strips or MAX marking plates.

## 8-1-13 VERTICAL AND HORIZONTAL TEXT SETTINGS

With vertical text, the layout for grip sleeves and tubes differs from that of other materials.

	Horizontal		Vertical	
Grip sleeves / Tubes				
Other				

**1** In LETATWIN PC EDITOR PRO select “File” - “Print settings.”

To display the print settings screen, access “File” ⇒ “Print settings” from the main editing screen or click on next to “Print settings” on the right hand side of the screen.

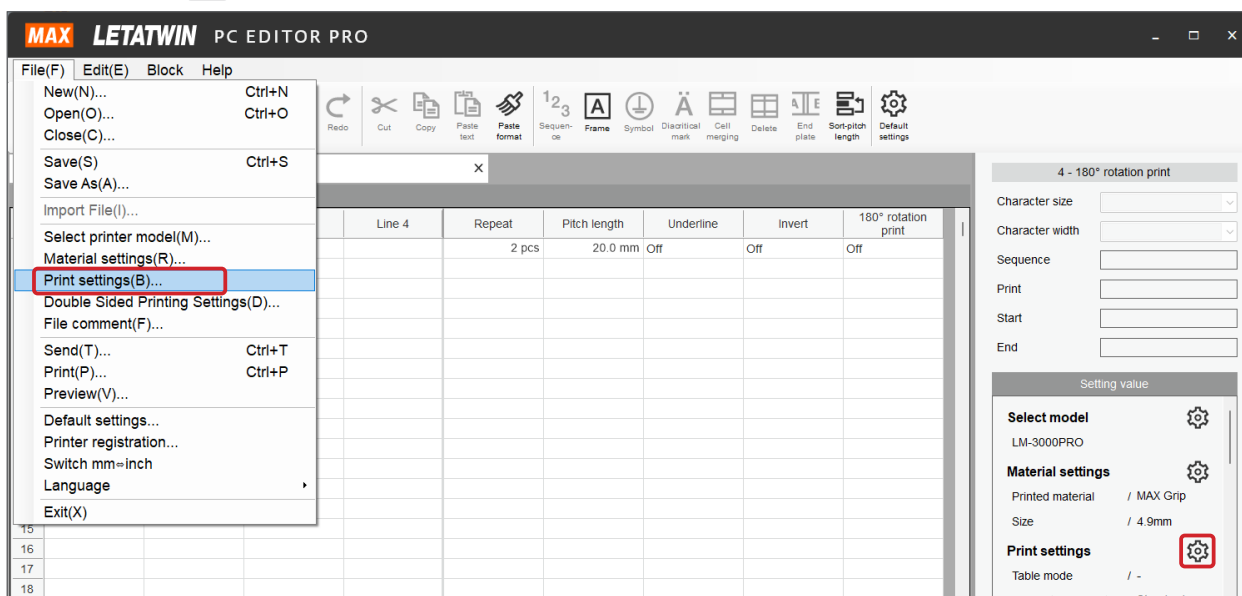

**2** From “Print settings” - “Vertical/Horizontal,” select “Vertical” or “Horizontal,” then click the “OK” button.

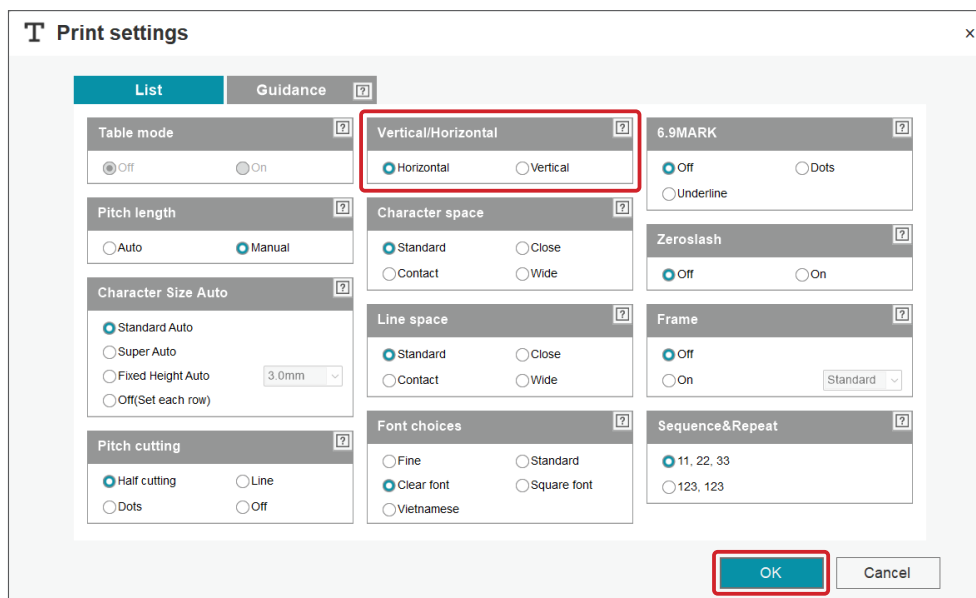

Setting can also be performed on the guidance screen.

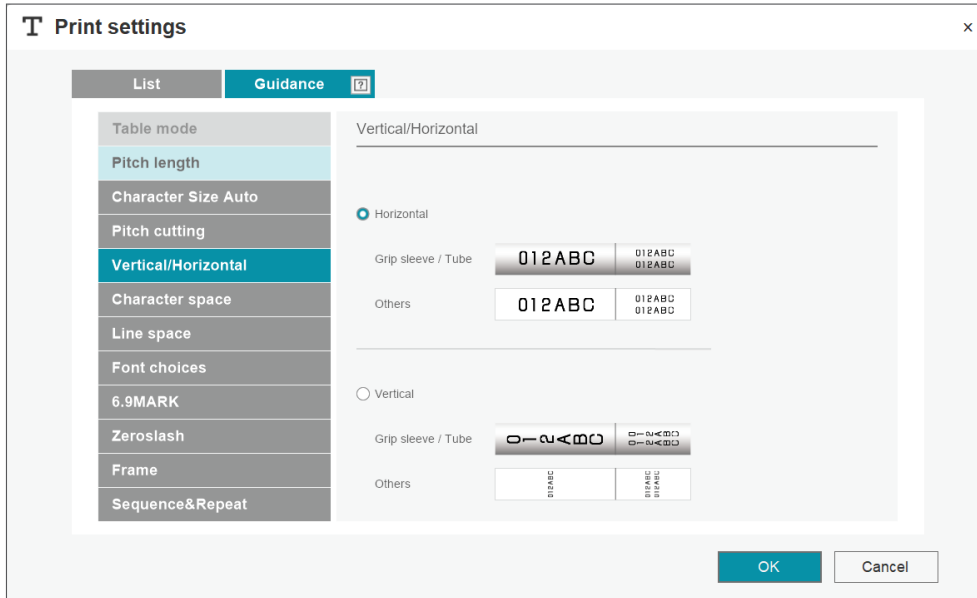

## 8-1-14 SETTING CHARACTER SPACING

Standard	AAA
Close	AAA
Contact	AAA
Wide	AAA

**1** In LETATWIN PC EDITOR PRO select “File” - “Print settings.”

To display the “Print settings” screen, access “File” ⇒ “Print settings” from the main editing screen or click on  next to “Print settings” on the right hand side of the screen.

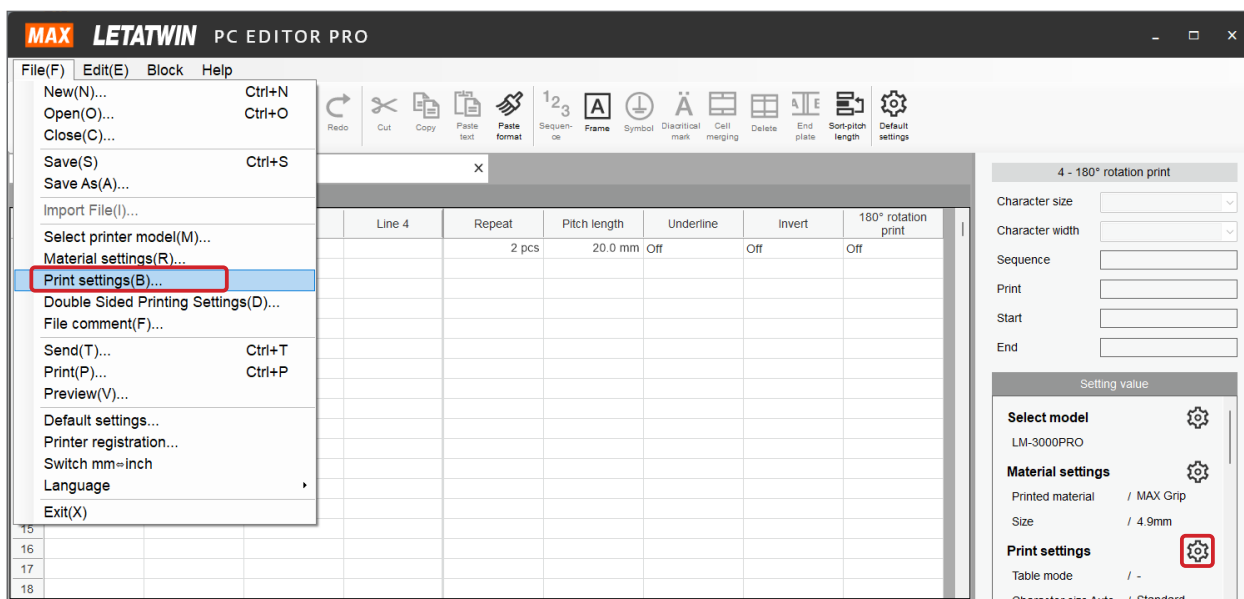

**2** From “Print settings” - “Character space”, select “Standard” or “Close” or “Contact” or “Wide,” then click the “OK” button.

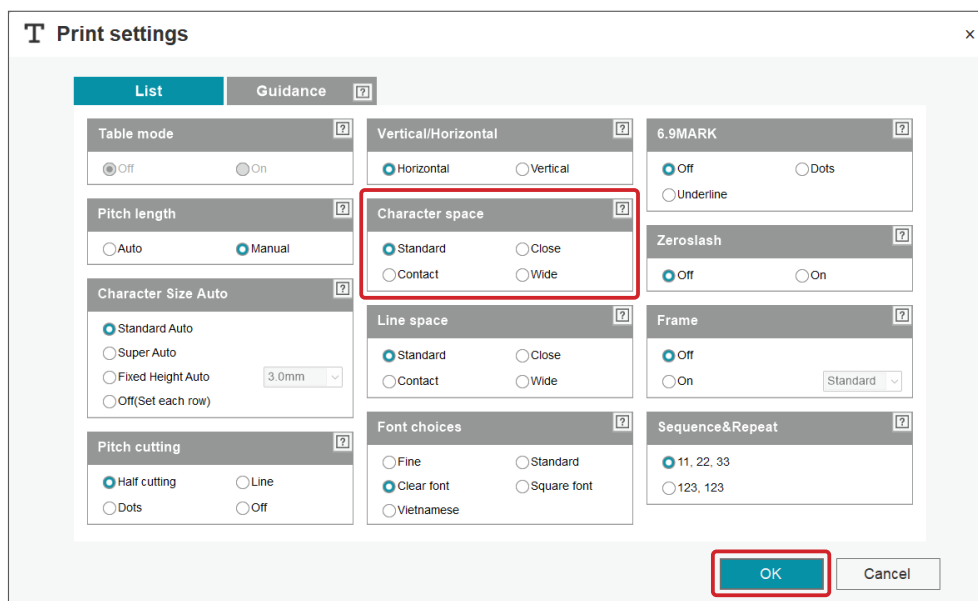

## MEMO

- “Character space” cannot be set with separate spacing for individual blocks. A single setting is applied to the entire document (all blocks).
- “Character space” is only enabled when “Character Size Auto” is set to “OFF.”
- If a “Print height exceeded” or “Pitch length exceeded” error message is displayed, reduce the character size for blocks marked with a cursor or reduce the “Character size” or “Line space.”
- “Character space” settings can be registered as default settings (initial values).

→ 8-9 REGISTERING DEFAULT SETTINGS (INITIAL VALUES)

Setting can also be performed on the guidance screen.

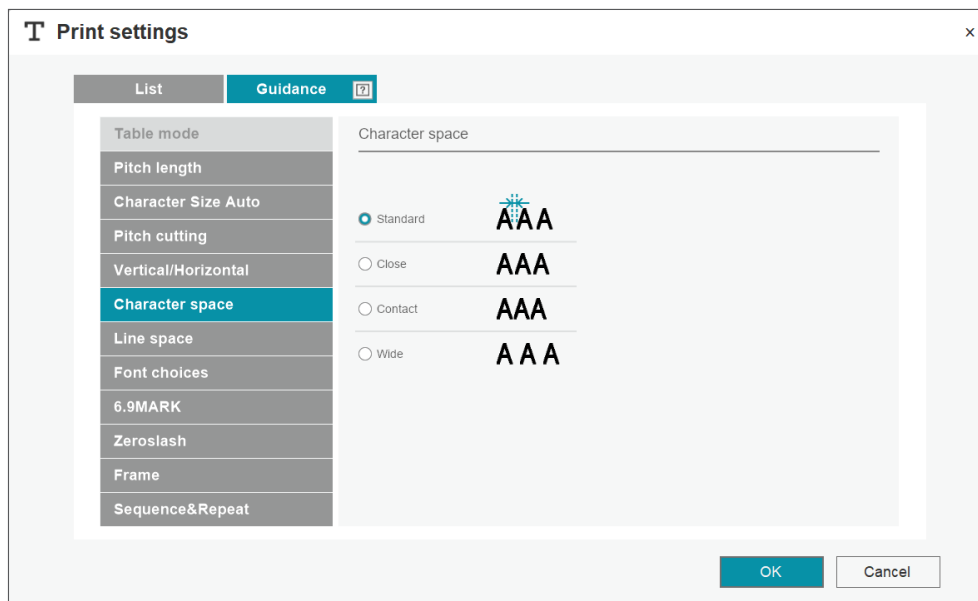

## 8-1-15 SETTING LINE SPACING

Standard	Close	Contact	Wide
AAA BBB	AAA BBB	AAA BBB	AAA BBB

**1** In LETATWIN PC EDITOR PRO select “File” - “Print settings.”

To display the “Print settings” screen, access “File” ⇒ “Print settings” from the main editing screen or click on  next to “Print settings” on the right hand side of the screen.

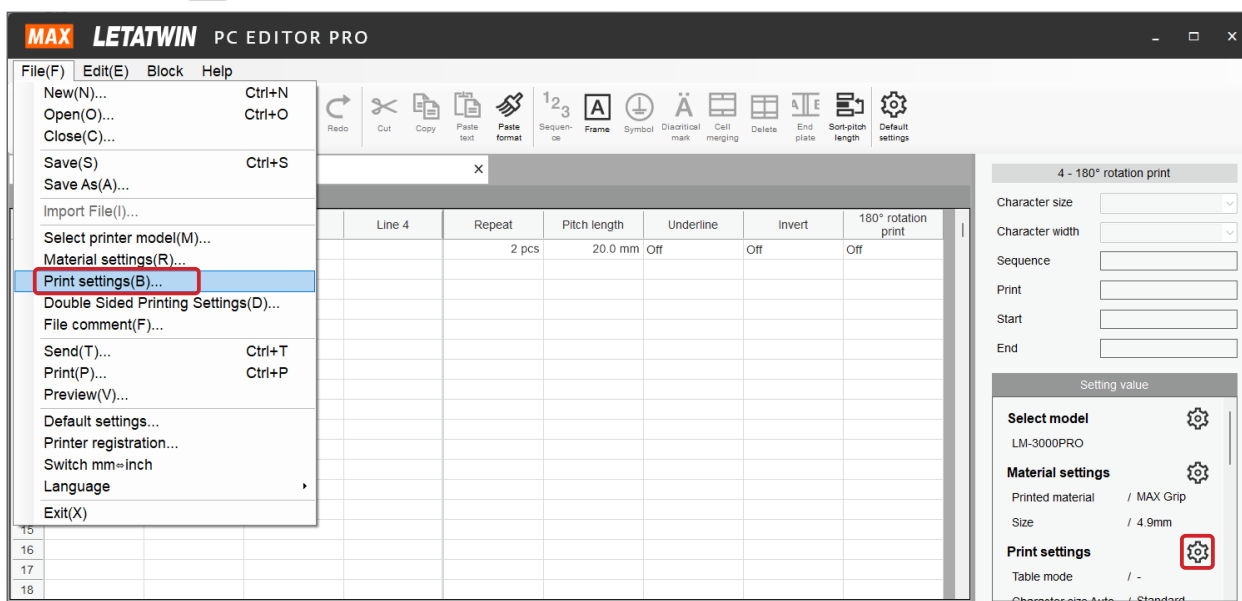

**2** From “Print settings” - “Line space,” select “Standard,” “Close,” “Contact” or “Wide,” then click the “OK” button.

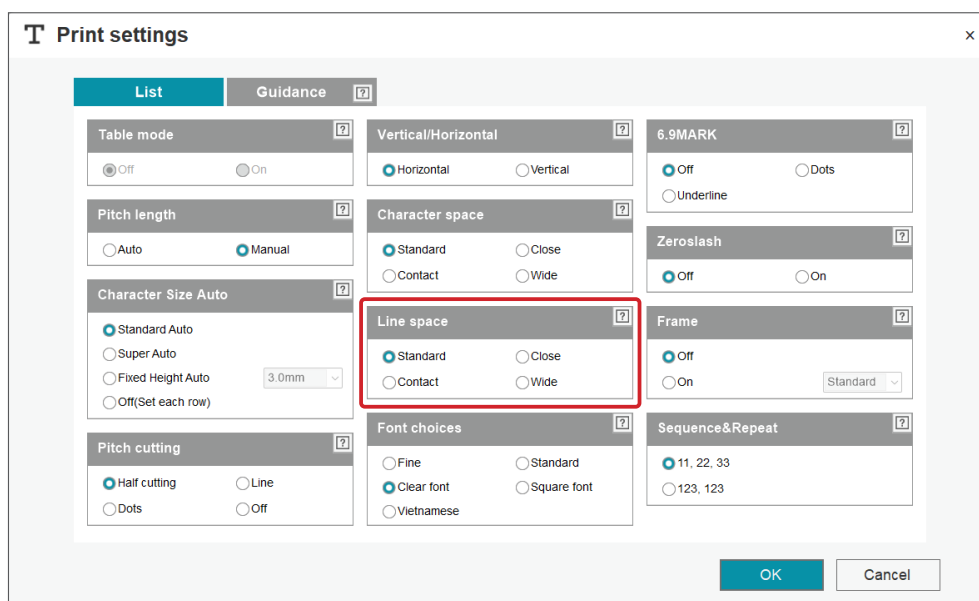

## MEMO

- “Line space” cannot be set with separate spacing for individual blocks. A single setting is applied to the entire document (all blocks).
- “Line space” is only enabled when “Character Size Auto” is set to “OFF.”
- If a “Print height exceeded” or “Pitch length exceeded” error message is displayed, reduce the character size for blocks marked with a cursor or reduce the “Character size” or “Line space.”
- “Line space” settings can be registered as default settings (initial values).

→ 8-9 REGISTERING DEFAULT SETTINGS (INITIAL VALUES)

Setting can also be performed on the guidance screen.

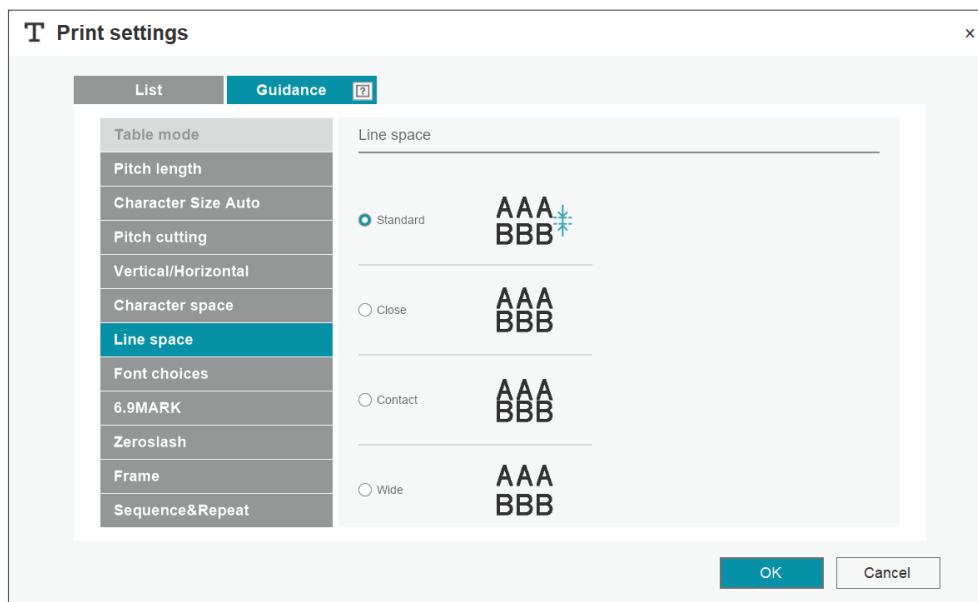

## 8-1-16 CHANGING THE FONT

Standard	0 1 2 3 4 5 A B C a b c
Bold	<b>0 1 2 3 4 5 A B C a b c</b>
Clear font	<b>0 1 2 3 4 5 A B C a b c</b>
Square font	<b>0 1 2 3 4 5 A B C a b c</b>
Vietnamese	0 1 2 3 4 5 A B C a b c ã Ç Ö â ç ø

- In LETATWIN PC EDITOR PRO select “File” - “Print settings.”  
To display the “Print settings” screen, access “File” ⇒ “Print settings” from the main editing screen or click on  next to “Print settings” on the right hand side of the screen.

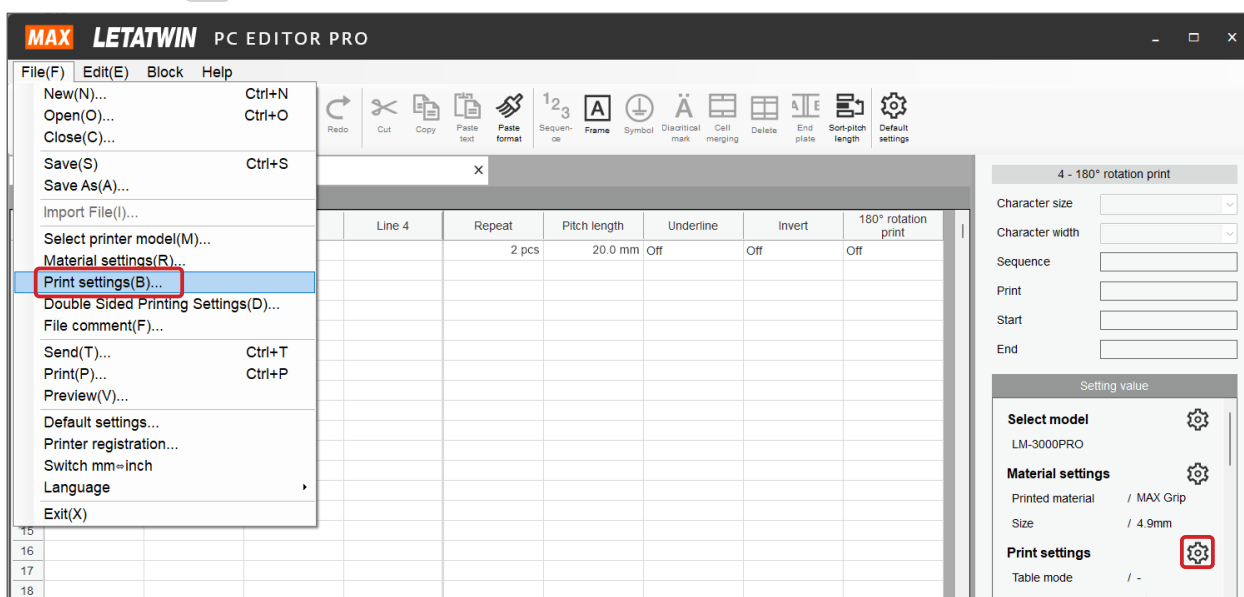

- Select from “Print settings” - “Font choices,” then click “OK.”

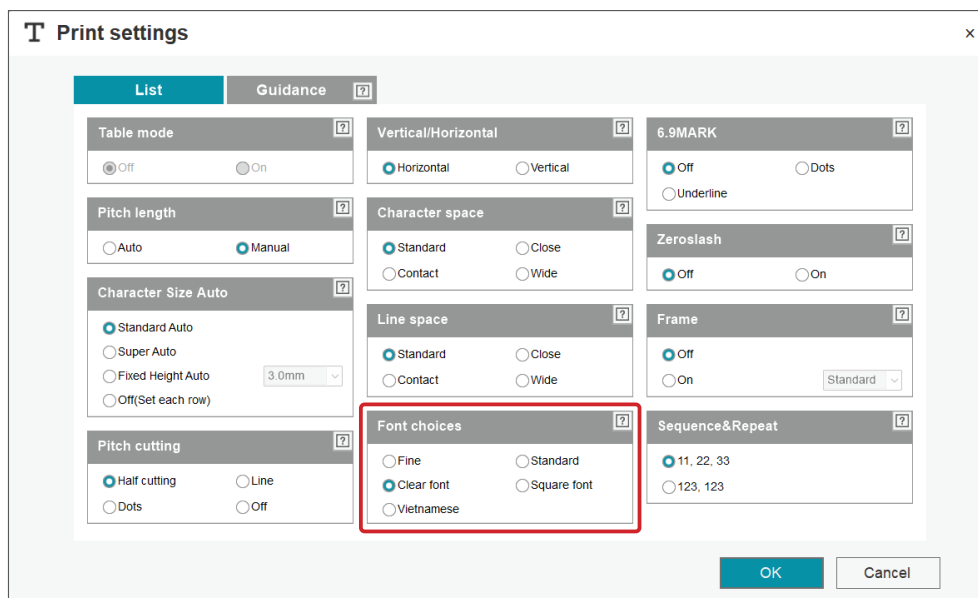

## MEMO

- For alphanumeric characters only, the following fonts can be selected: Standard, Bold, Clear, Square, and Vietnamese.
- When the font is set to Bold, Clear font, Square font or Vietnamese, combining alphanumeric characters with non-alphanumeric characters (kanji, hiragana, katakana and symbols) can cause the text to become unbalanced.
- Character height during actual printing varies depending on the font.
- Fonts can be registered as default settings (initial values).

→ 8-9 REGISTERING DEFAULT SETTINGS (INITIAL VALUES)

- “Clear font” is a font with character shapes designed to enhance recognizability.

→ 8-2-4 USING CLEAR FONT

When the Vietnamese font is selected, the font of characters with diacritics (Â, â, etc.) changes.

- With the LM-550A, fonts cannot be selected through LETATWIN PC EDITOR PRO. The font set on the main unit is applied.

# 8-2 ENHANCING CHARACTER RECOGNIZABILITY

## 8-2-1 CHANGING PRINTING OF “6” AND “9”

The way that “6” and “9” in documents are printed can be set in order to make it easier to tell them apart.

OFF	6 9
Dot	6. 9.
Underline	<u>6</u> <u>9</u>

**1** In LETATWIN PC EDITOR PRO select “File” - “Print settings.”

To display the “Print settings” screen, access “File” ⇒ “Print settings” from the main editing screen or click on  next to “Print settings” on the right hand side of the screen.

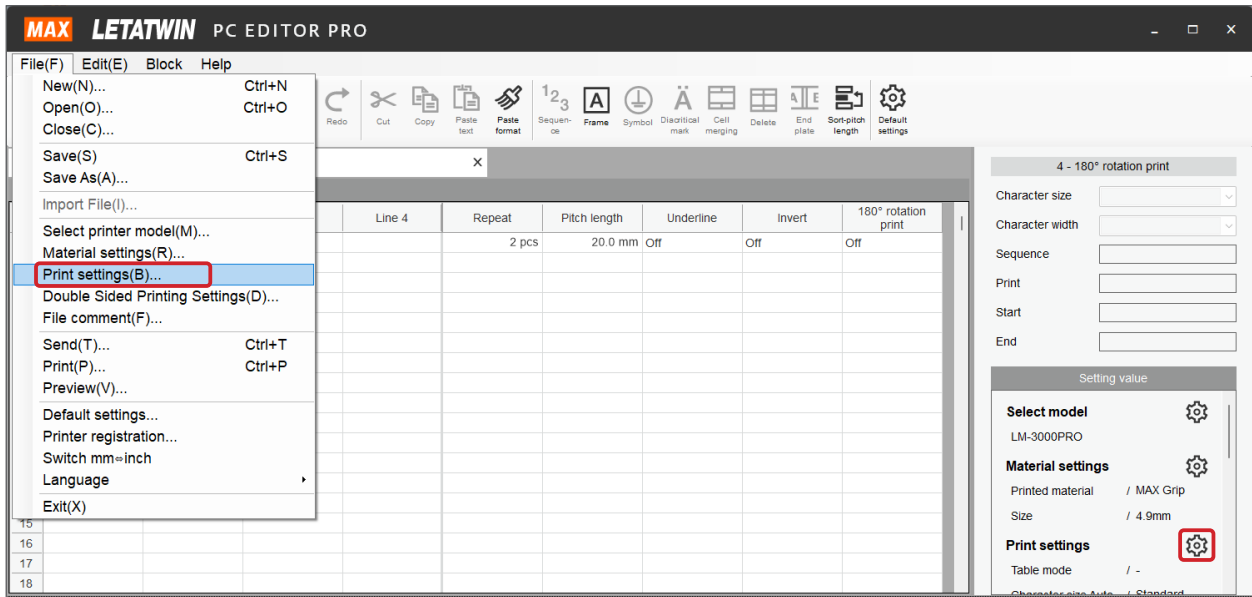

**2** Select a marking style in the “6.9MARK” field on the “Print settings” screen, then click the “OK” button.

 Setting can also be performed on the guidance screen.

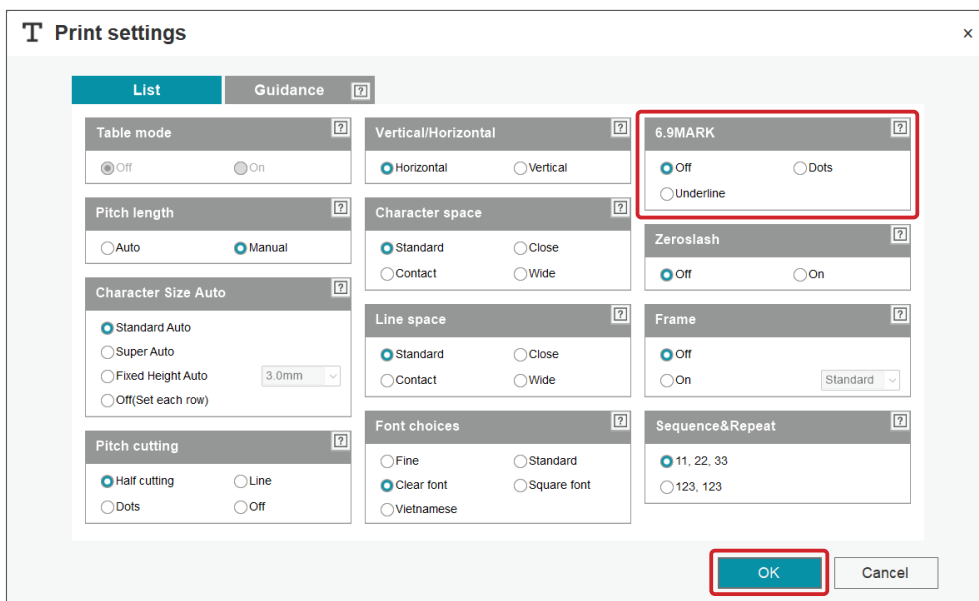

### 3 Guidance

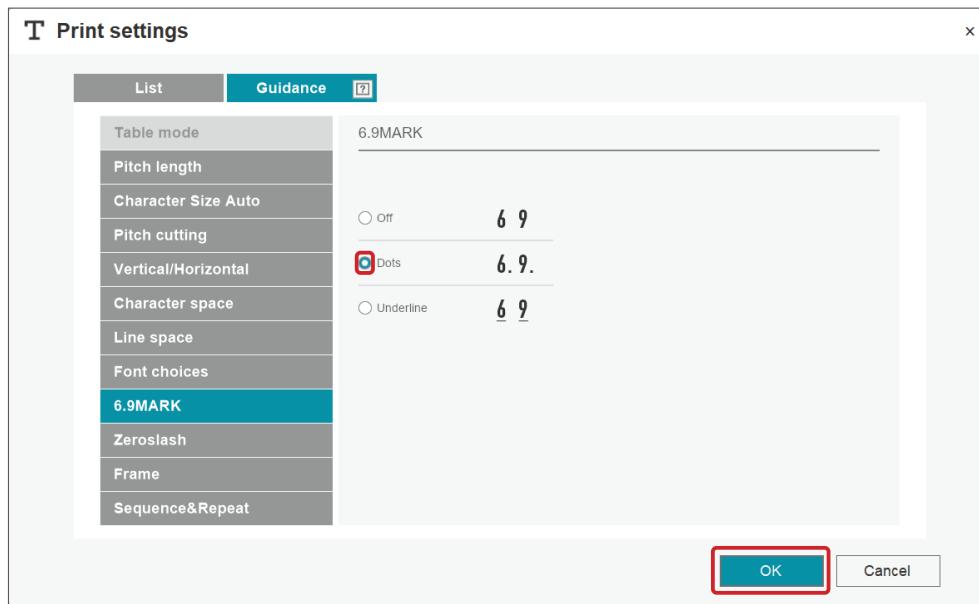

### 4 The settings are applied.

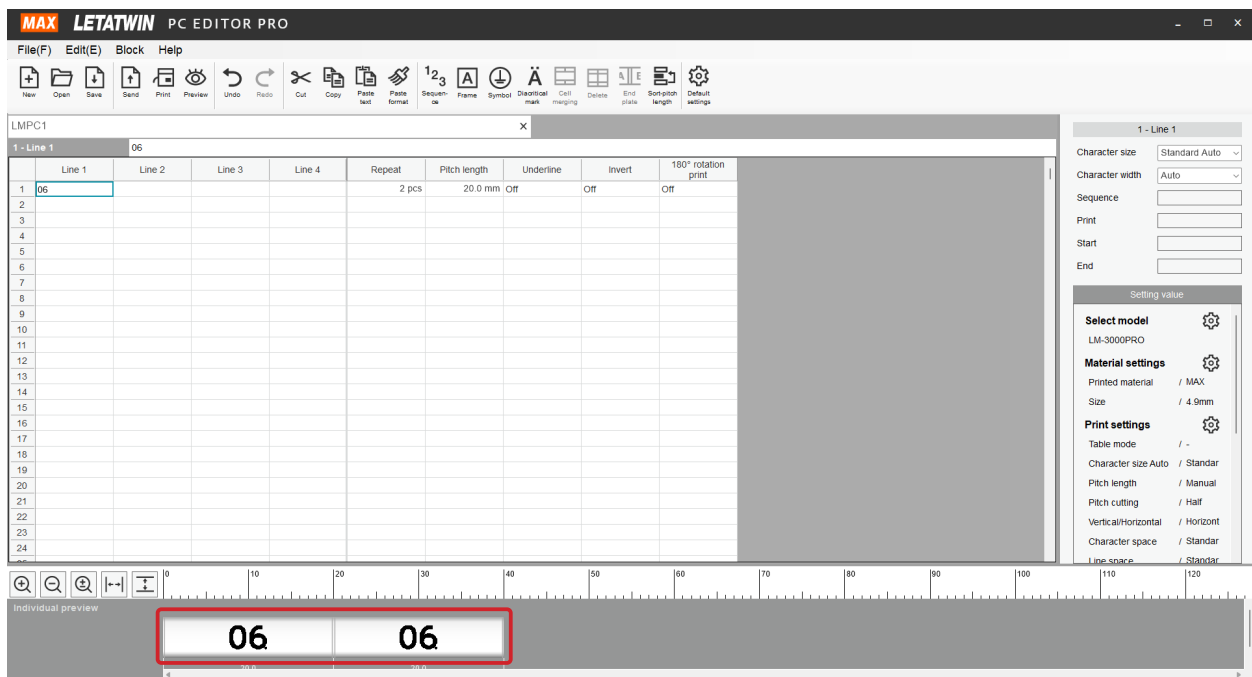

#### MEMO

- “6” and “9” print settings can be registered as default settings (initial values).  
 → 8-9 REGISTERING DEFAULT SETTINGS (INITIAL VALUES)
- With the LM-550A3/550A2/550A, these settings cannot be changed through the app. Adjust the settings on the main unit.

## 8-2-2 ADDING SLASHES TO ZEROS (“0”)

Slashes can be added to zeros to make zero (“0”) and the letter “O” easier to tell apart.

OFF	0
ON	0

**1** In LETATWIN PC EDITOR PRO select “File” - “Print settings.”

To display the “Print settings” screen, access “File” ⇒ “Print settings” from the main editing screen or click on  next to “Print settings” on the right hand side of the screen.

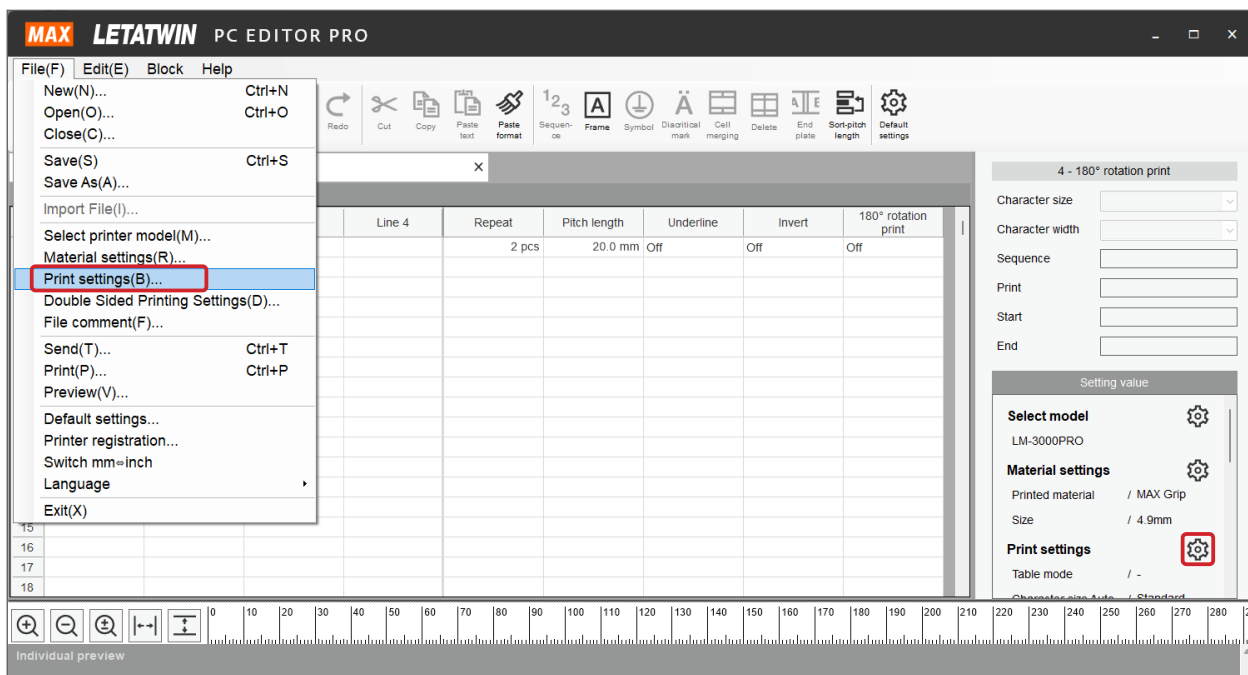

**2** Select “ON” in the “Zero slash” field on the “Print settings” screen, then, click the “OK” button.

 Setting can also be performed on the guidance screen.

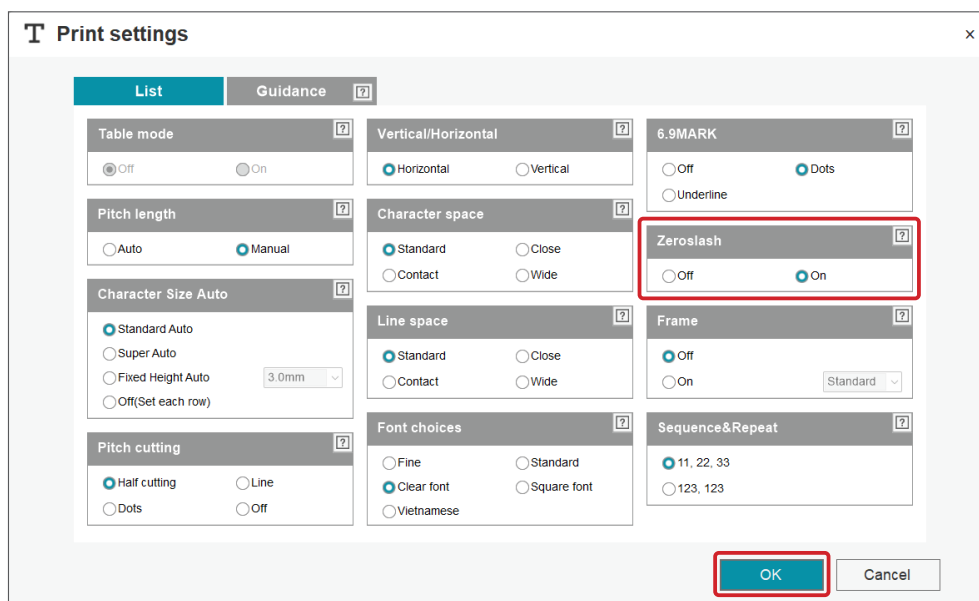

### 3 Guidance

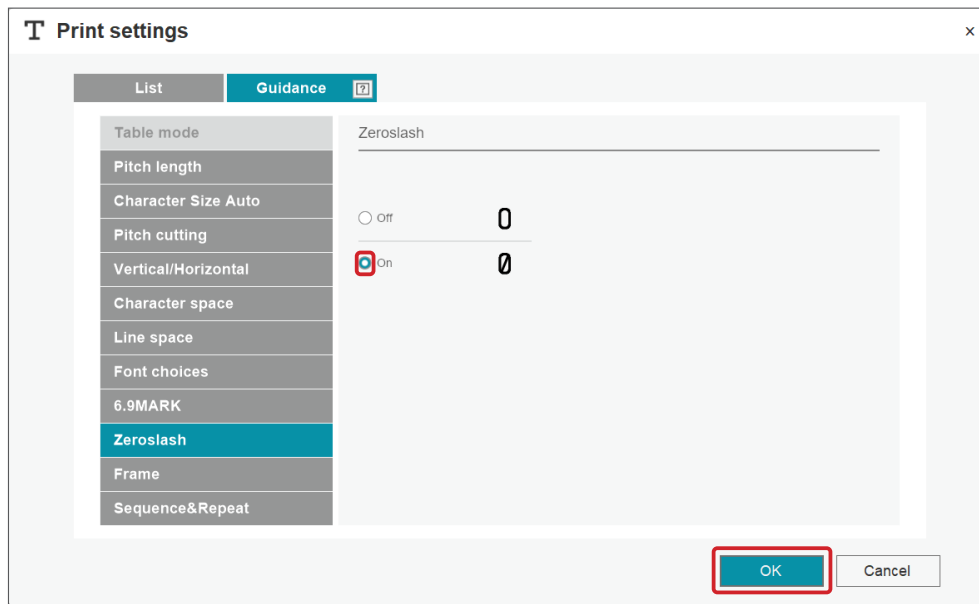

### 4 The settings are applied.

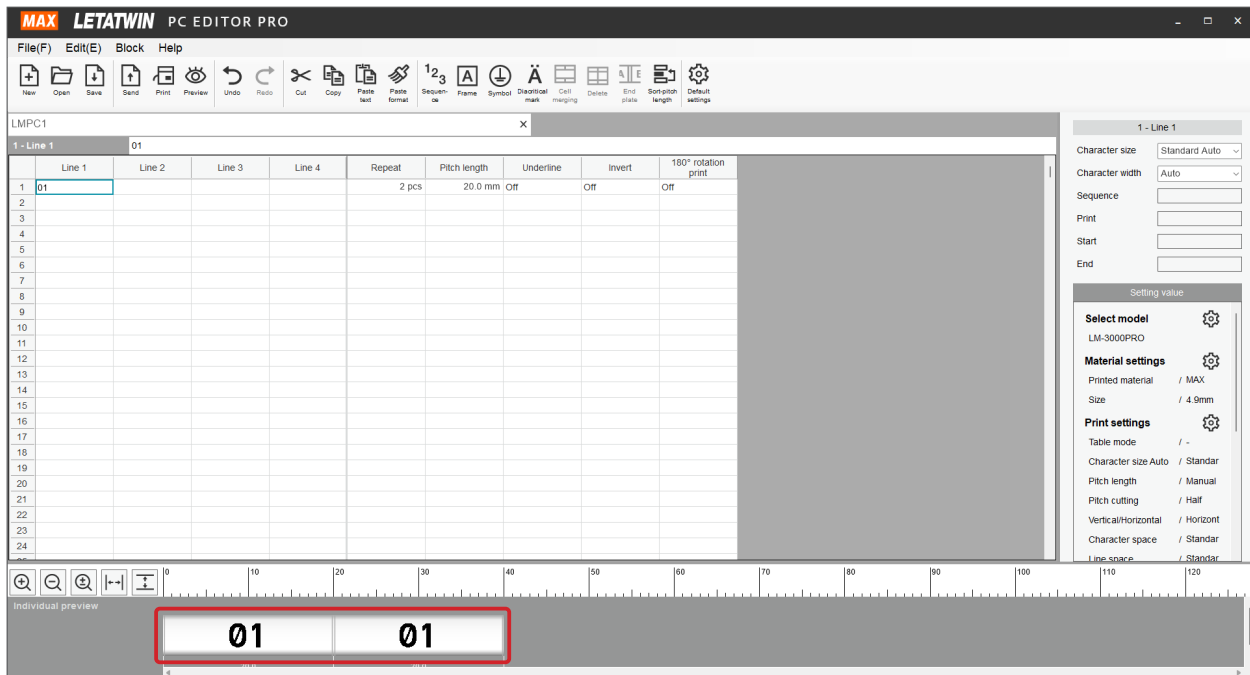

#### MEMO

- The “Zero slash” setting can be registered as a default setting (initial value).  
 → 8-9 REGISTERING DEFAULT SETTINGS (INITIAL VALUES)
- The LM-550A2/550A do not support a setting for adding slashes to zeros. On the LM-550A2, zeros with slashes are used when the Clear font is selected.

## 8-2-3 BATCH ADDITION OF PERIODS AFTER TEXT

Periods can be added to the end of all documents in a single operation to make the tube orientation visible at a glance.



**1** Select “Edit” - “Period” - “Add.”

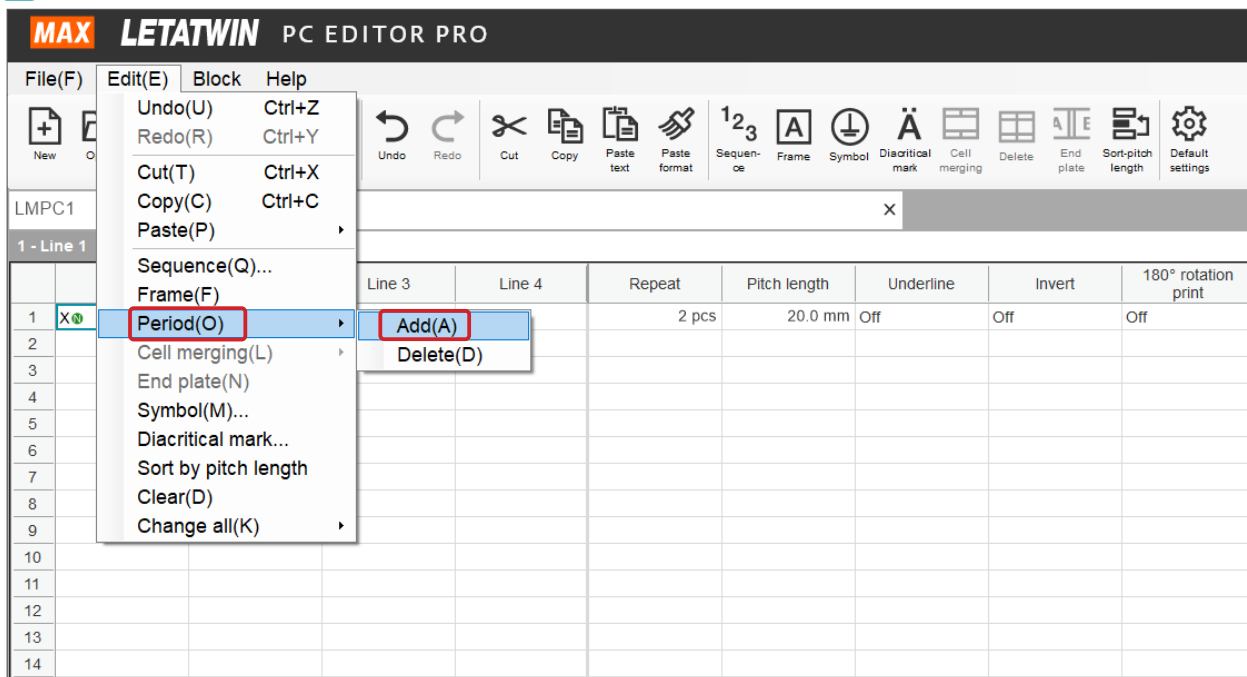

**2** A period is added.

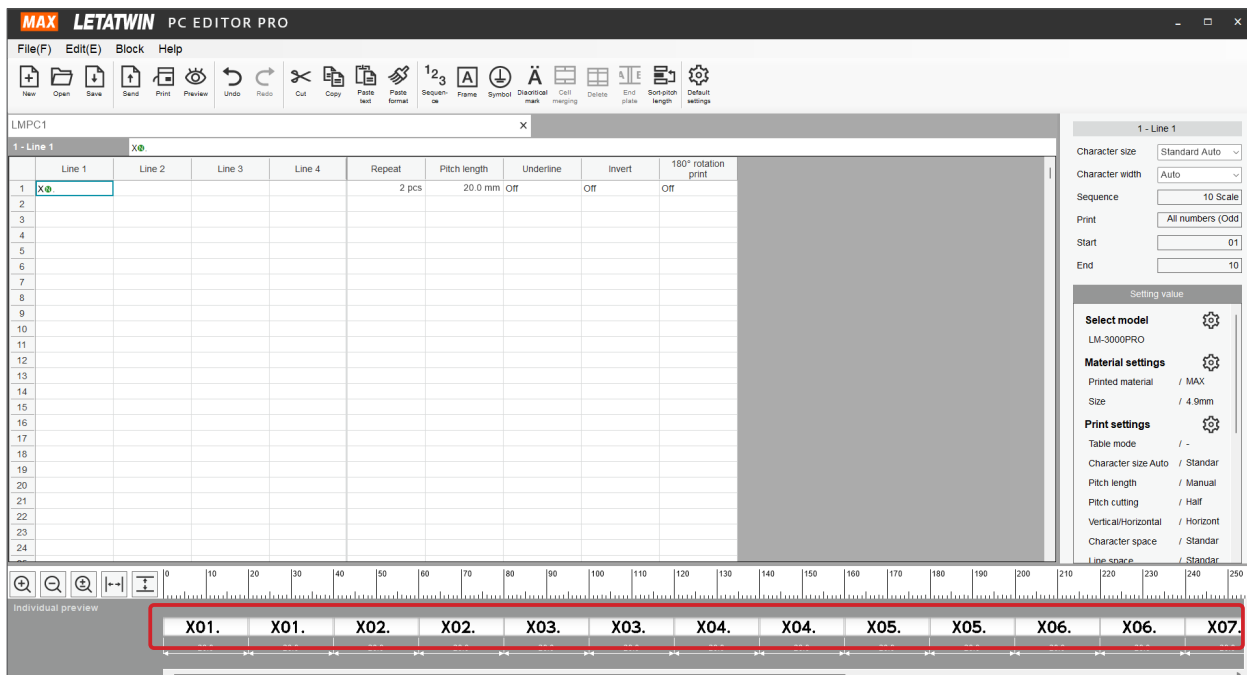

- Period addition can only be performed for data for which input has been completed. If new documents are added, apply the period setting again.

## 8-2-4 USING CLEAR FONT

Clear font is a font with a special design intended to make characters more easily identifiable.

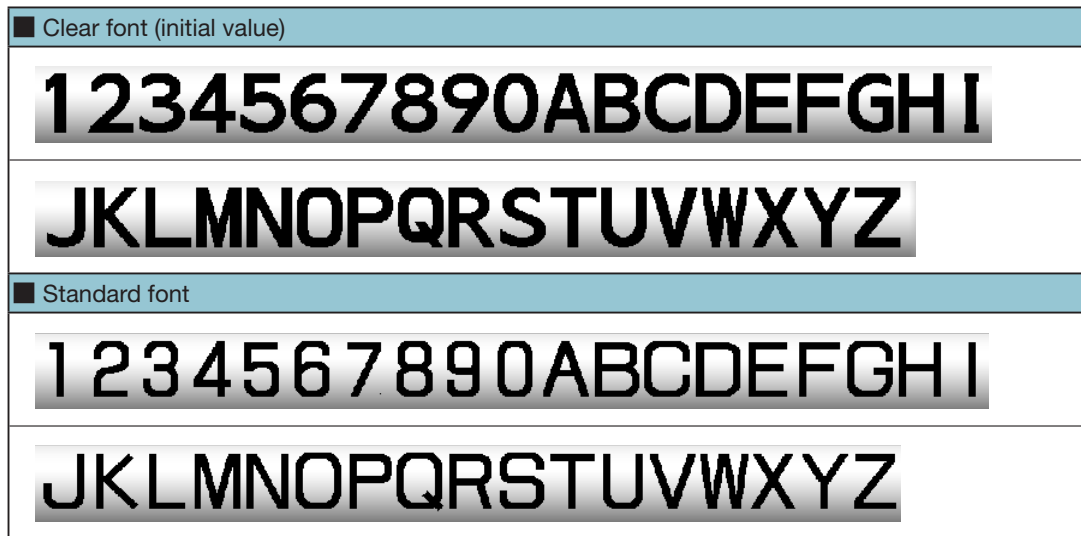

### MEMO

- The font can be selected through “Print settings.” → [8-1-16 CHANGING THE FONT](#)
- Fonts can be registered as default settings (initial values).  
→ [8-9 REGISTERING DEFAULT SETTINGS \(INITIAL VALUES\)](#)
- Clear font cannot be used on the LM-550A.

# 8-3 SETTING THE PRINT MODE AT LOW TEMPERATURES

## 8-3-1 USING THE TUBE HEATER

In environments with a temperature of 5 to 15°C, tubes may harden and printed text may become blurred or faint.



In such cases, the tube heater can be used to heat tubes to soften them and improve print quality.

**Supported tube diameters:  $\varnothing$ 1.5 to  $\varnothing$ 4.6.**

The heater is turned on and off using the LCD display. For details on operation, refer to Chapter 6 ("MAIN UNIT LCD CONTENT").

\*The tube heater can only be used on tubes. It cannot be used on other print material.

→ 6-5 SWITCHING THE HEATER ON AND OFF

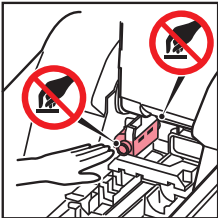
 <b>WARNING</b>	
 	<ul style="list-style-type: none"><li>• <b>Never touch the tube inlet and outlet</b> Doing so can cause burns.</li></ul> <div style="text-align: right;"> <small>*For LM-3000PRO</small></div>

## 8-3-2 LOWERING THE PRINT SPEED

In environments with a temperature of 5 to 15°C, printed text may become faint.

In such cases, try setting the machine to low temperature mode.

- 1** Press the  icon.

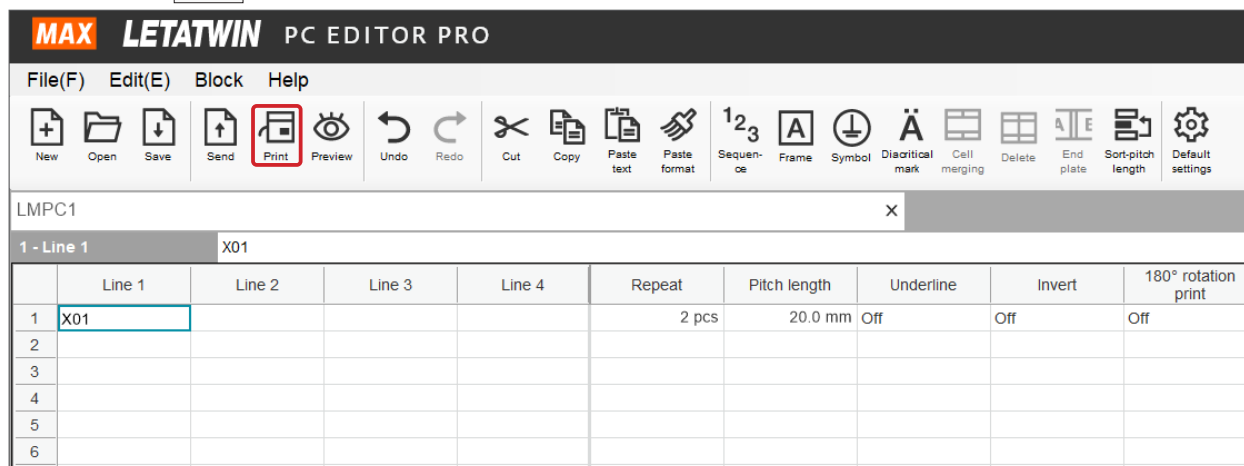

- 2** Set “Low Temp. mode” to “ON.”

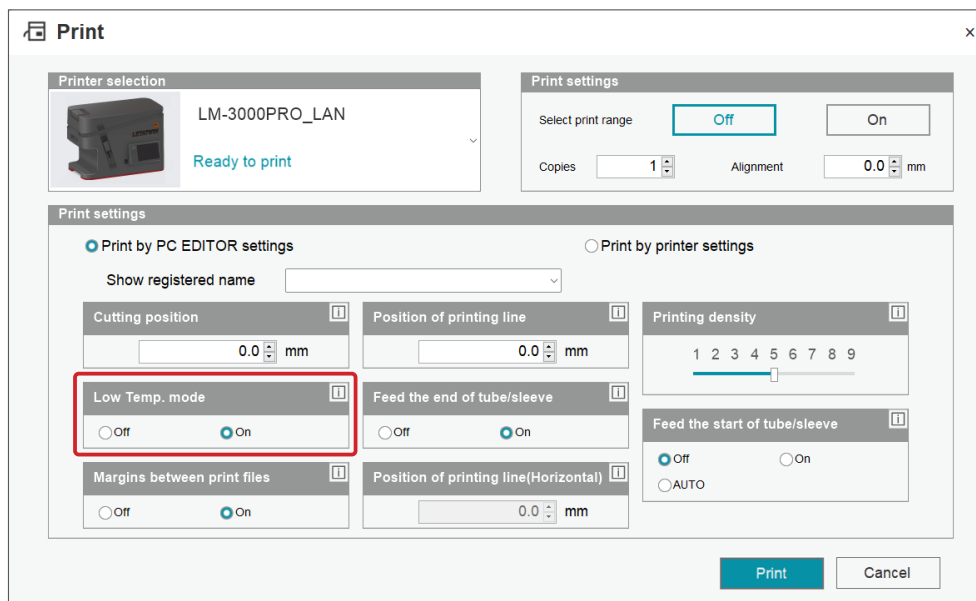

### MEMO

- When printing using “Print using main printer unit settings” from the PC EDITOR “Print” screen or when printing data from a USB memory device using the main printer only, set “Low temperature mode” to “ON” on the main unit, then perform printing.  
→ [6-9-2 SETTING LOW TEMPERATURE MODE](#)
- When low temperature mode is activated on the main unit, the main unit setting is maintained even after turning off the power. To return to the standard speed, set “02 Low temperature mode” to “OFF.”
- In PC EDITOR, the low temperature mode setting can be registered as a default setting (initial value). → [8-9 REGISTERING DEFAULT SETTINGS \(INITIAL VALUES\)](#)

## 8-3-3 ADJUSTING THE PRINTING DENSITY

The printing density (the density with which characters are printed) can be adjusted.

Initial value	Supported models
5	LM-3000PRO
4	LM-550A3 / 550A2 / 550A

**1** Press the  icon.

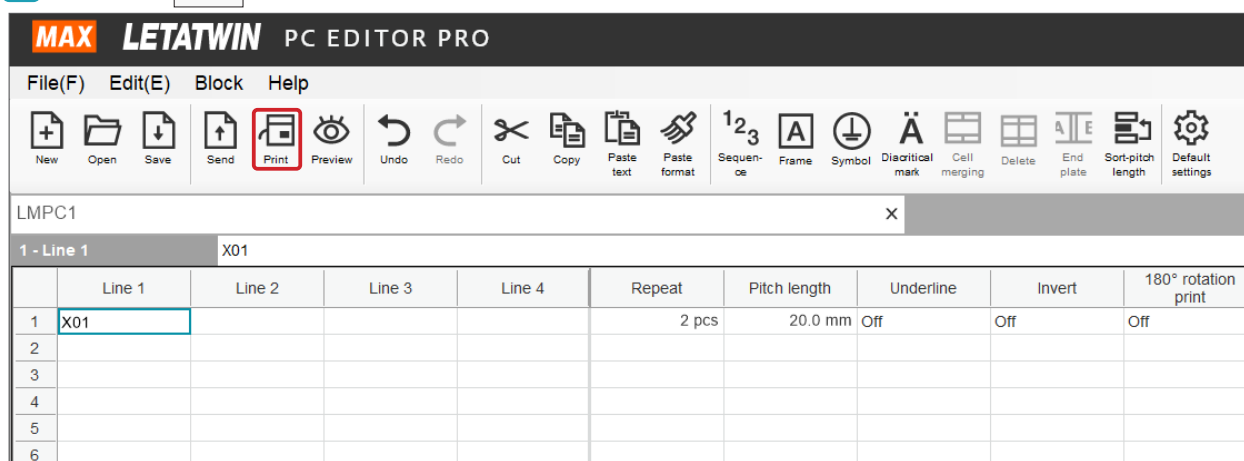

**2** Change the “Printing density” value.

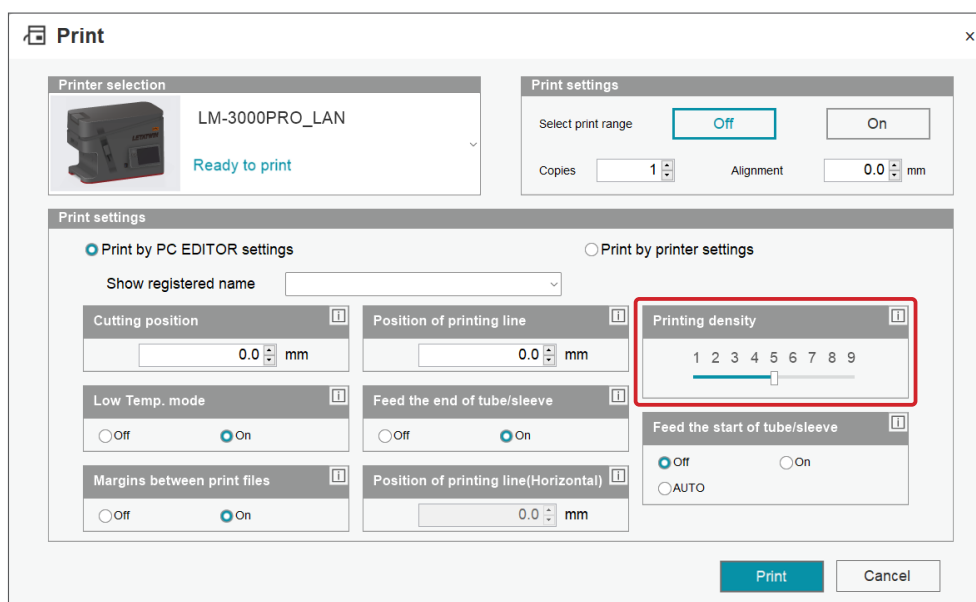

### MEMO

- If the ink ribbon sticks to the printing material together, try reducing the “Printing density” setting.
- In PC EDITOR, the low temperature mode setting can be registered as a default setting (initial value). → [8-9 REGISTERING DEFAULT SETTINGS \(INITIAL VALUES\)](#)
- When printing using “Print using main printer unit settings” from the PC EDITOR “Print” screen or when printing data from a USB memory device using the main printer only, set the “Printing density” on the main unit, then perform printing.

→ [6-9-1 SETTING THE PRINTING DENSITY](#)

# 8-4 SETTING SEQUENCES

## 8-4-1 SETTING SEQUENCES

Sequences can be set for documents. The types of sequences that can be set are as follows.

Mode	Setting range	Output	Example of print output
8 Scale	0 to 7777	All, Odd numbers only, Even numbers only	<input type="text" value="MC5"/> <input type="text" value="MC6"/> <input type="text" value="MC7"/> <input type="text" value="MC10"/> <input type="text" value="MC11"/>
10 Scale	0 to 9999		<input type="text" value="X001"/> <input type="text" value="X002"/> <input type="text" value="X003"/> <input type="text" value="X004"/> <input type="text" value="X005"/>
16 Scale	0 to FFFF		<input type="text" value="F08"/> <input type="text" value="F09"/> <input type="text" value="F0A"/> <input type="text" value="F0B"/> <input type="text" value="F0C"/>
Uppercase letters	A to Z	All	<input type="text" value="Output A"/> <input type="text" value="Output B"/> <input type="text" value="Output C"/> <input type="text" value="Output D"/> <input type="text" value="Output E"/>
Lowercase letters	a to z	All	<input type="text" value="Monitor a"/> <input type="text" value="Monitor b"/> <input type="text" value="Monitor c"/> <input type="text" value="Monitor d"/> <input type="text" value="Monitor e"/>
Two sequence combination	Dependent on sequence type	Dependent on sequence type	<input type="text" value="A001"/> <input type="text" value="B002"/> <input type="text" value="C003"/> <input type="text" value="D004"/> <input type="text" value="E005"/>
Three sequence combination	Dependent on sequence type	Dependent on sequence type	<input type="text" value="A001a"/> <input type="text" value="B002b"/> <input type="text" value="C003c"/> <input type="text" value="D004d"/> <input type="text" value="E005e"/>

1 Press the  icon.

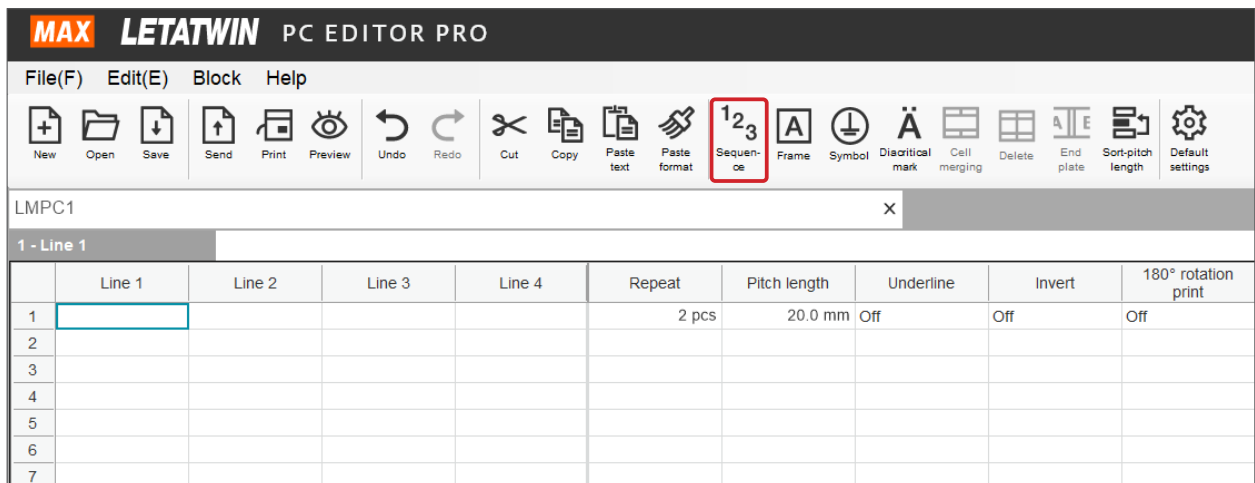

2 Select the “Mode” / “Output” format, enter the “Start” and “End” numbers, then click the “Insert” button.

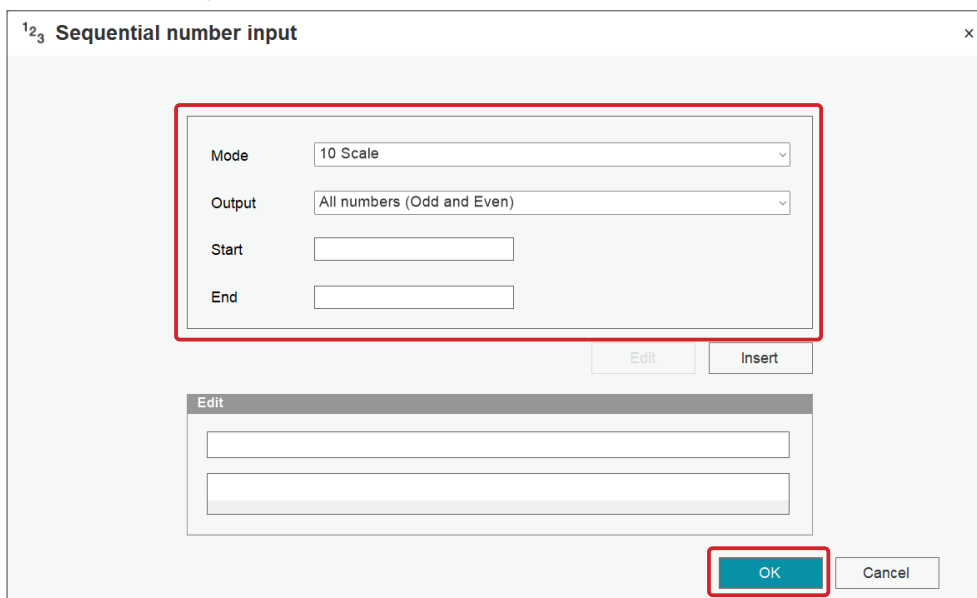

**3** A **N** symbol is shown in the “Edit” fields.

The screenshot shows a dialog box titled "1<sub>2</sub><sub>3</sub> Sequential number input". It contains several input fields: "Mode" (set to "10 Scale"), "Output" (set to "All numbers (Odd and Even)"), "Start" (set to "01"), and "End" (set to "10"). Below these are "Edit" and "Insert" buttons. At the bottom are "OK" and "Cancel" buttons. An "Edit" section is open, showing two empty text input fields. Each field has a small green circle with a white "N" inside, which is highlighted by a red box.

**4** Alphanumeric characters that do not depend on the sequence can be entered directly into the “Edit” fields.

Example input: X

Click the “OK” button.

This screenshot shows the same dialog box as above, but now the two text input fields in the "Edit" section contain the character "X". Each "X" is followed by a small green circle with a white "N" inside. A red box highlights the "OK" button at the bottom right of the dialog.

**5** The entered data is applied.

**MAX LETATWIN PC EDITOR PRO**

File(F) Edit(E) Block Help

New Open Save Send Print Preview Undo Redo Cut Copy Paste text Paste format Sequence Frame Symbol Diacritical mark Cell merging Delete End plate Sort-pitch length Default settings

LMPC1 X

1 - Line 1 X

	Line 1	Line 2	Line 3	Line 4	Repeat	Pitch length	Underline	Invert	180° rotation print
1	X				2 pcs	20.0 mm	Off	Off	Off
2									
3									
4									
5									
6									
7									
8									
9									
10									
11									
12									
13									
14									

**MEMO**

- Three sequences can be set per block and 45 sequences can be set over the entire document.
- With the LM-550A sequence settings, one sequence can be set per block and up to 15 sequences can be set over the entire document.
- Sequence numbers can be set in descending order (10, 9, 8, 7...3, 2, 1) by entering "10" as the start "1" as the end.
- When two or three sequences are set for one block, if their respective number of print items differ, the lower number is prioritized and items above that number are not printed.

## 8-4-2 SETTING THE ORDER FOR PRINTING SEQUENCES

The output order can be set when printing repeated sequences.

	Prioritize repeat	Prioritize sequence
Setting range	X1 X1 X2 X2 X3 X3	X1 X2 X3 X1 X2 X3

- Click “File” ⇒ “Print settings” or  button.

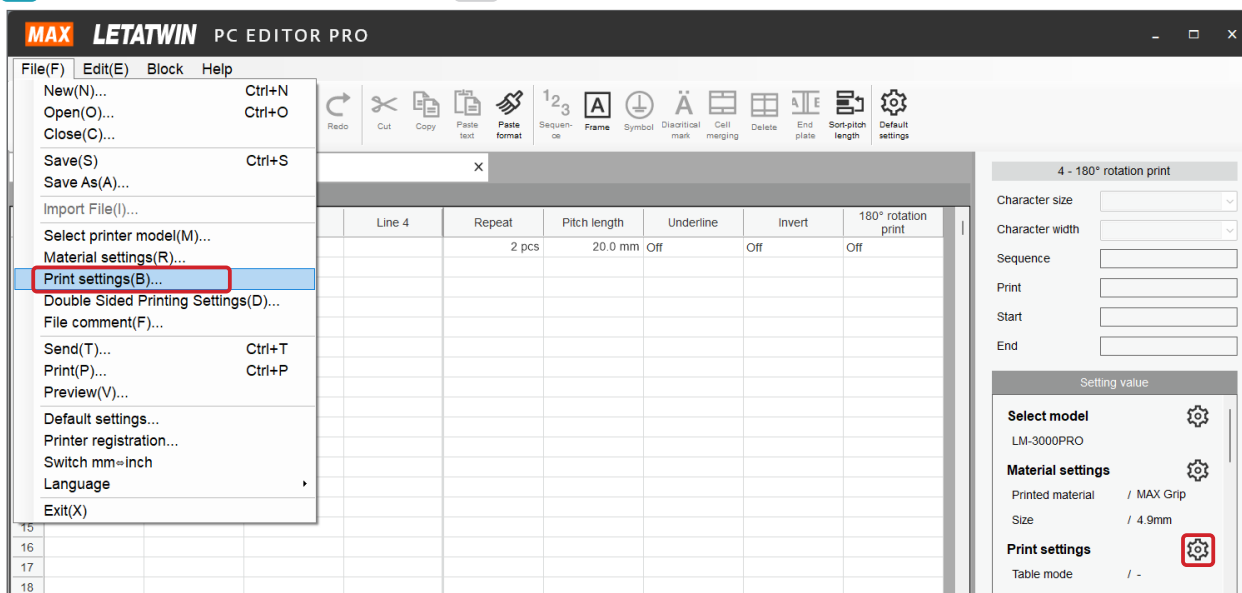

- From the “Sequence & Repeat” field, select “Prioritize repeat” or “Prioritize sequence,” then click the “OK” button.

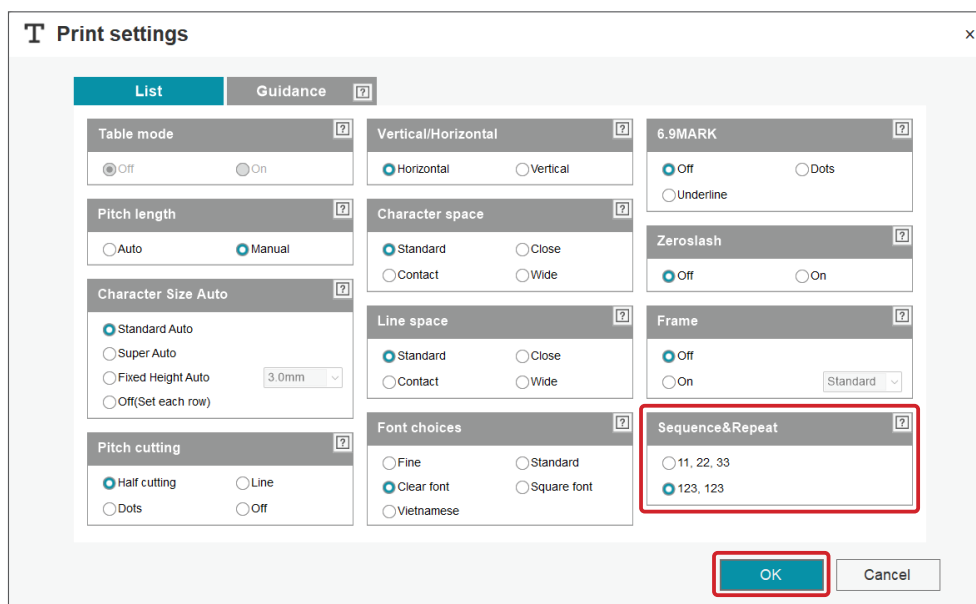

### MEMO

- The “Sequence & Repeat” is only enabled when using sequences entered with the “Sequence” function. It is not applied to sequences entered by hand.
- The “Sequence & Repeat” setting can be registered as a default setting (initial value).

→ 8-9 REGISTERING DEFAULT SETTINGS (INITIAL VALUES)

# 8-5 ENTERING SYMBOLS AND TEXT WITH DIACRITICS

## 8-5-1 ENTERING ELECTRICAL INSTALLATION SYMBOLS

Example input: Earth symbol

- 1 Click the  icon.

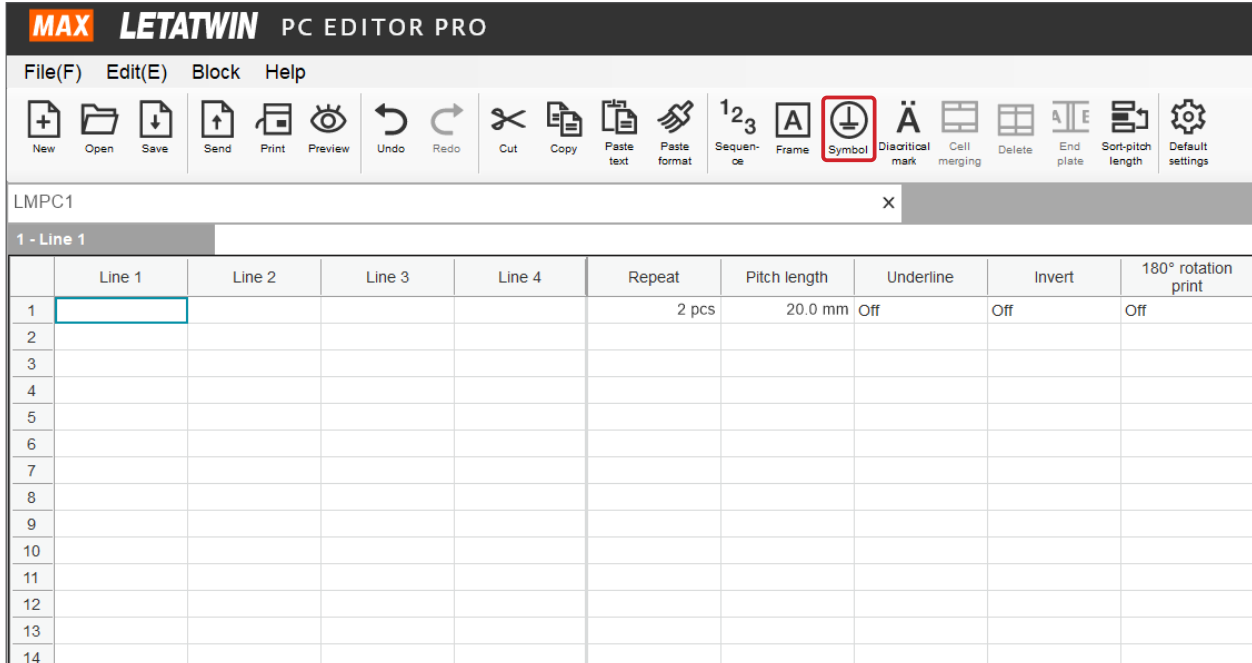

The screenshot shows the LETATWIN PC EDITOR PRO software interface. The title bar reads "MAX LETATWIN PC EDITOR PRO". The menu bar includes "File(F)", "Edit(E)", "Block", and "Help". The toolbar contains various icons for file operations (New, Open, Save, Send, Print, Preview), editing (Undo, Redo, Cut, Copy, Paste text, Paste format), and symbol entry (Symbol, Diacritical mark, Cell merging, Delete, End plate, Sort-pitch length, Default settings). The "Symbol" icon is highlighted with a red box. Below the toolbar is a window titled "LMPC1" with a tab "1 - Line 1". The main area is a table with columns: Line 1, Line 2, Line 3, Line 4, Repeat, Pitch length, Underline, Invert, and 180° rotation print. The first row (Line 1) has "2 pcs" in the Repeat column, "20.0 mm" in the Pitch length column, and "Off" in the Underline, Invert, and 180° rotation print columns.

	Line 1	Line 2	Line 3	Line 4	Repeat	Pitch length	Underline	Invert	180° rotation print
1					2 pcs	20.0 mm	Off	Off	Off
2									
3									
4									
5									
6									
7									
8									
9									
10									
11									
12									
13									
14									

- 2 Select "Group" - "Electrical installation-1."

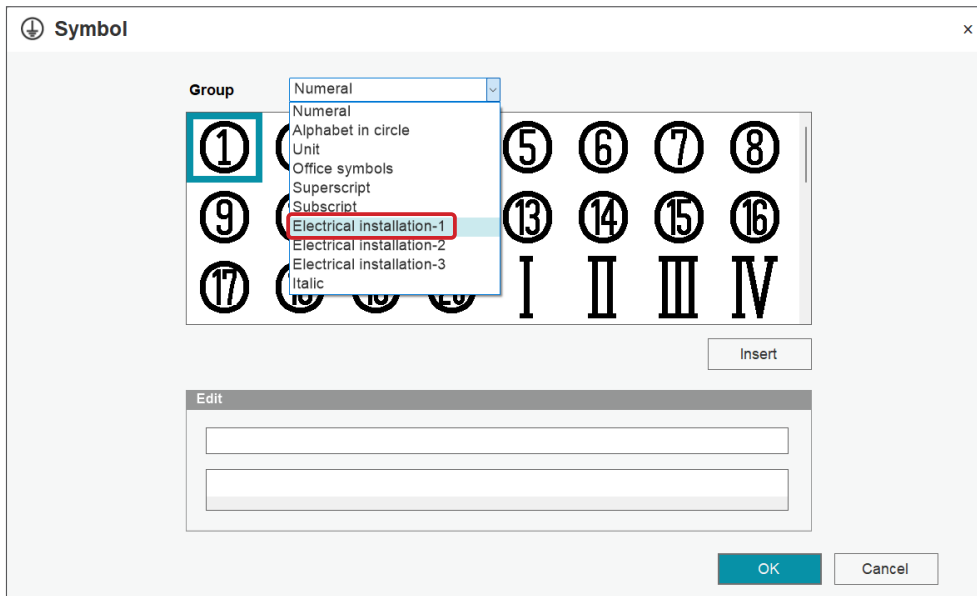

The screenshot shows the "Symbol" dialog box. The "Group" dropdown menu is open, showing a list of options: "Numeral", "Alphabet in circle", "Unit", "Office symbols", "Superscript", "Subscript", "Electrical installation-1", "Electrical installation-2", "Electrical installation-3", and "Italic". The "Electrical installation-1" option is highlighted with a red box. To the right of the dropdown menu, there is a grid of symbols: "5", "6", "7", "8", "9", "13", "14", "15", "16", and Roman numerals "I", "II", "III", "IV". Below the grid is an "Insert" button. At the bottom of the dialog box, there is an "Edit" section with two text input fields, and "OK" and "Cancel" buttons.

- 3** Select the earth symbol, then click on the “Insert” button.

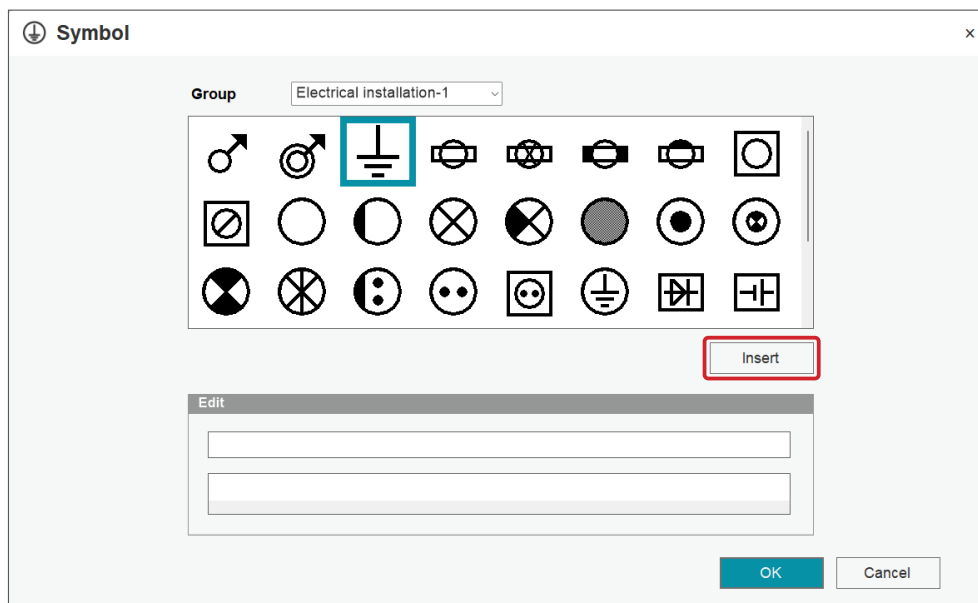

- 4** A **S** symbol is shown in the “Edit” fields. Click the “OK” button.

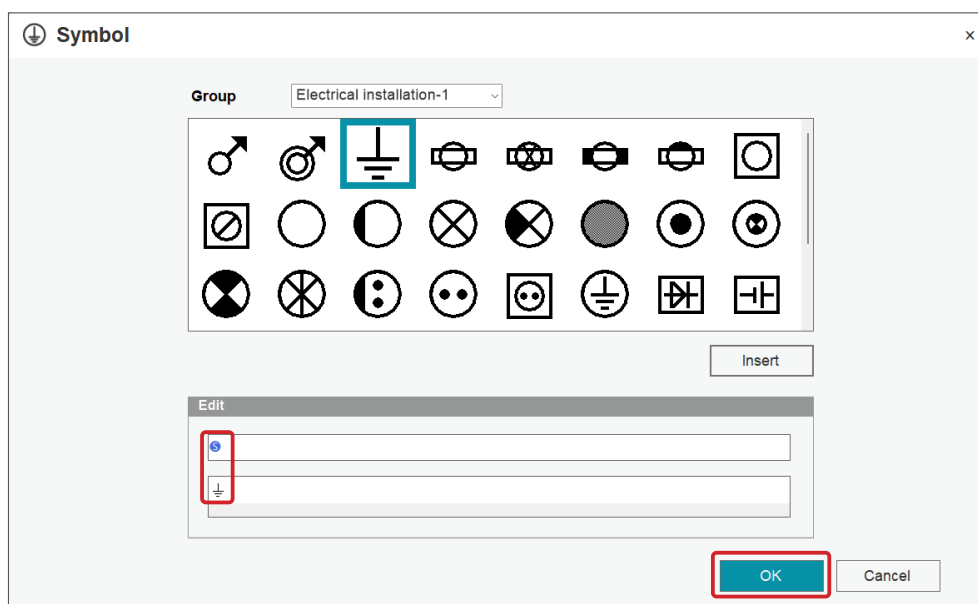

5 The symbol is applied.

**MAX LETATWIN PC EDITOR PRO**

File(F) Edit(E) Block Help

New Open Save Send Print Preview Undo Redo Cut Copy Paste text Paste format Sequence Frame Symbol Diacritical mark Cell merging Delete End plate Sort-pitch length Default settings

LMPC1 X

1 - Line 1

	Line 1	Line 2	Line 3	Line 4	Repeat	Pitch length	Underline	Invert	180° rotation print
1	↓				2 pcs	20.0 mm	Off	Off	Off
2									
3									
4									
5									
6									
7									
8									
9									
10									
11									
12									
13									
14									

## 8-5-2 ENTERING SYMBOLS AND TEXT WITH DIACRITICS

Example input: Ä

- 1 Click the  icon.

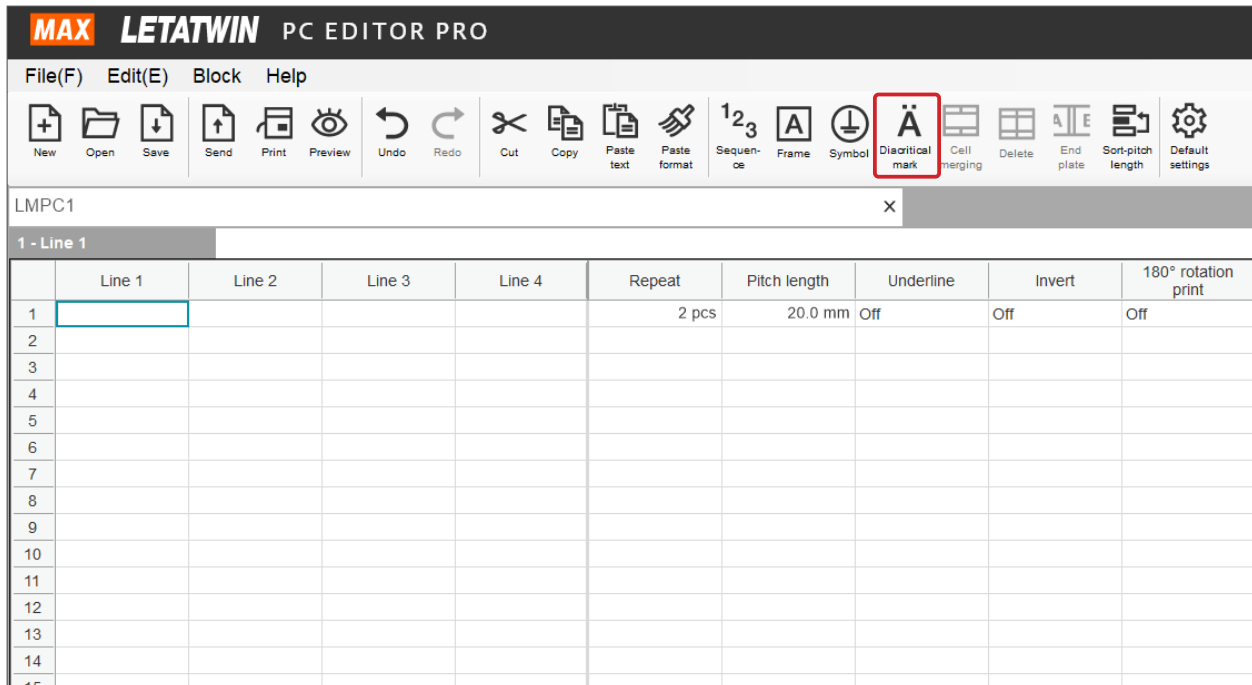

	Line 1	Line 2	Line 3	Line 4	Repeat	Pitch length	Underline	Invert	180° rotation print
1					2 pcs	20.0 mm	Off	Off	Off
2									
3									
4									
5									
6									
7									
8									
9									
10									
11									
12									
13									
14									
15									

- 2 Select a character, then click the “Insert” button.

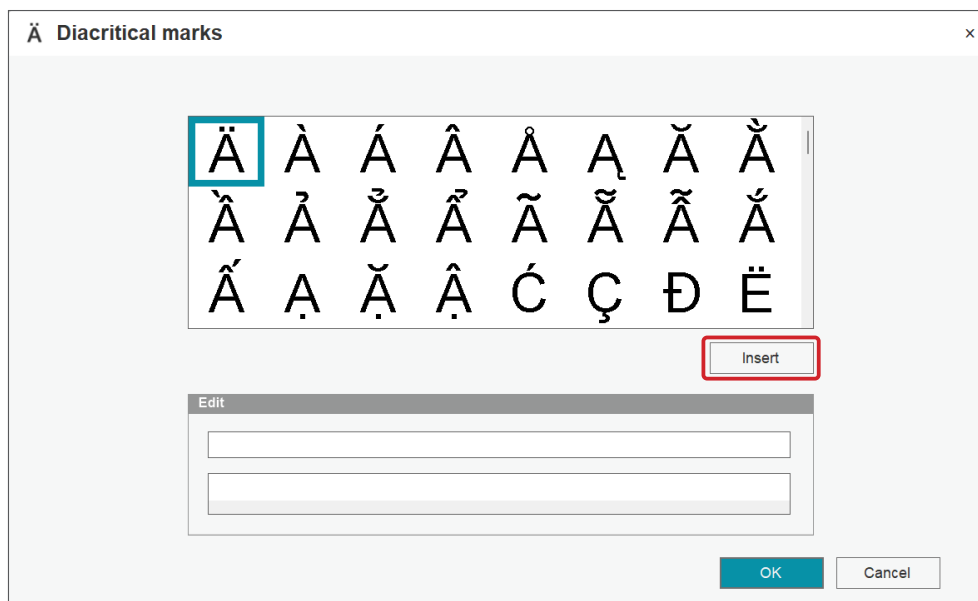

Ä Diacritical marks

Ä	À	Á	Â	Ã	Ä	Å	Ă	Ą
Ǽ	Ǻ	ǻ	Ǽ	ǽ	ǿ	Ǿ	ǿ	ǿ
Ǻ	ǻ	Ǽ	ǽ	ǿ	Ǿ	ǿ	ǿ	ǿ
Ǻ	ǻ	Ǽ	ǽ	ǿ	Ǿ	ǿ	ǿ	ǿ

Insert

Edit

OK Cancel

**3** The entered content is applied to the “Edit” fields.

Click the “OK” button.

\*Consecutive characters with diacritical marks can be entered on the “Diacritical marks” screen.

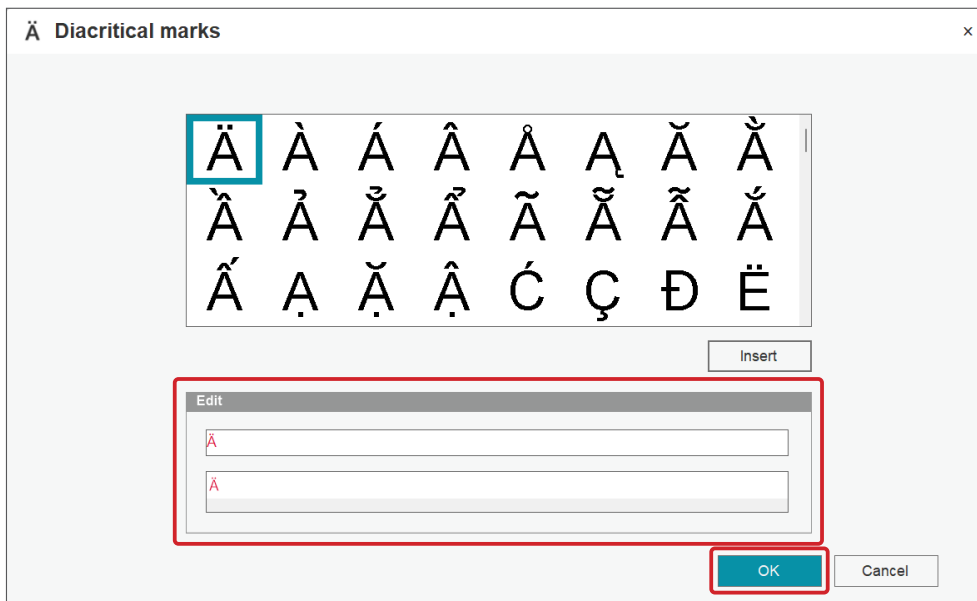

**4** The entered content is applied.

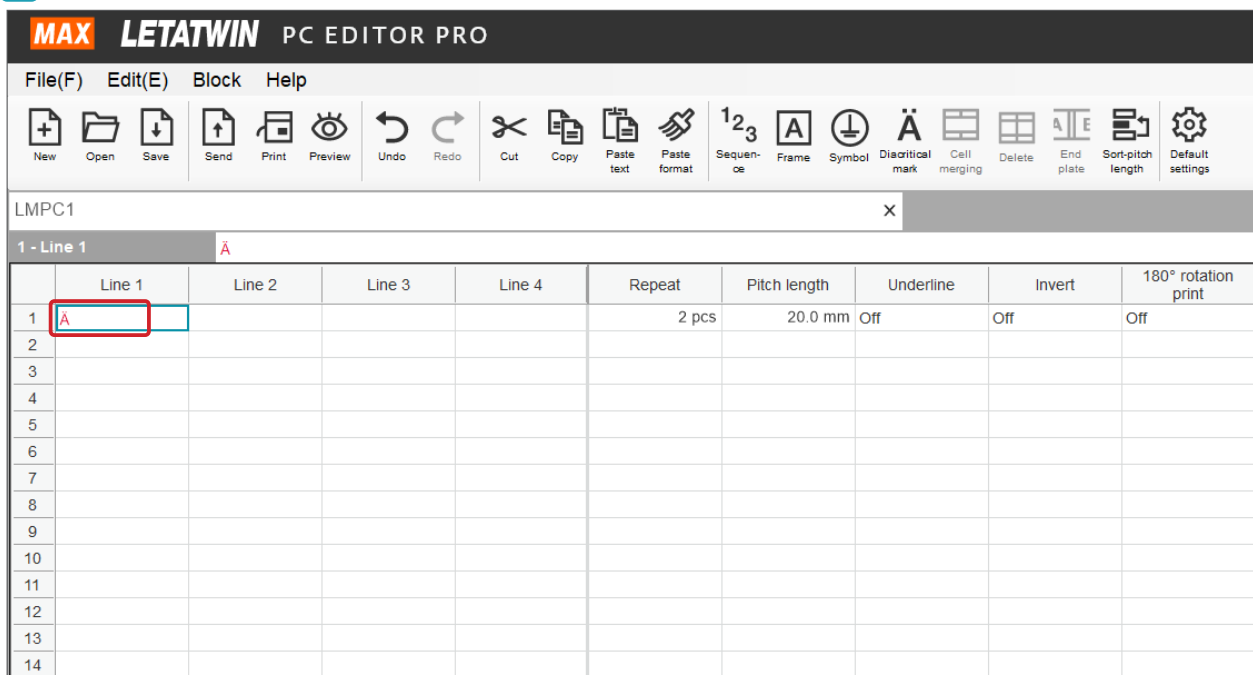

# 8-6 CHECKING PREVIEWS

## 8-6-1 VIEWING INDIVIDUAL PREVIEWS

**1** Individual previews display the content entered within a single block.

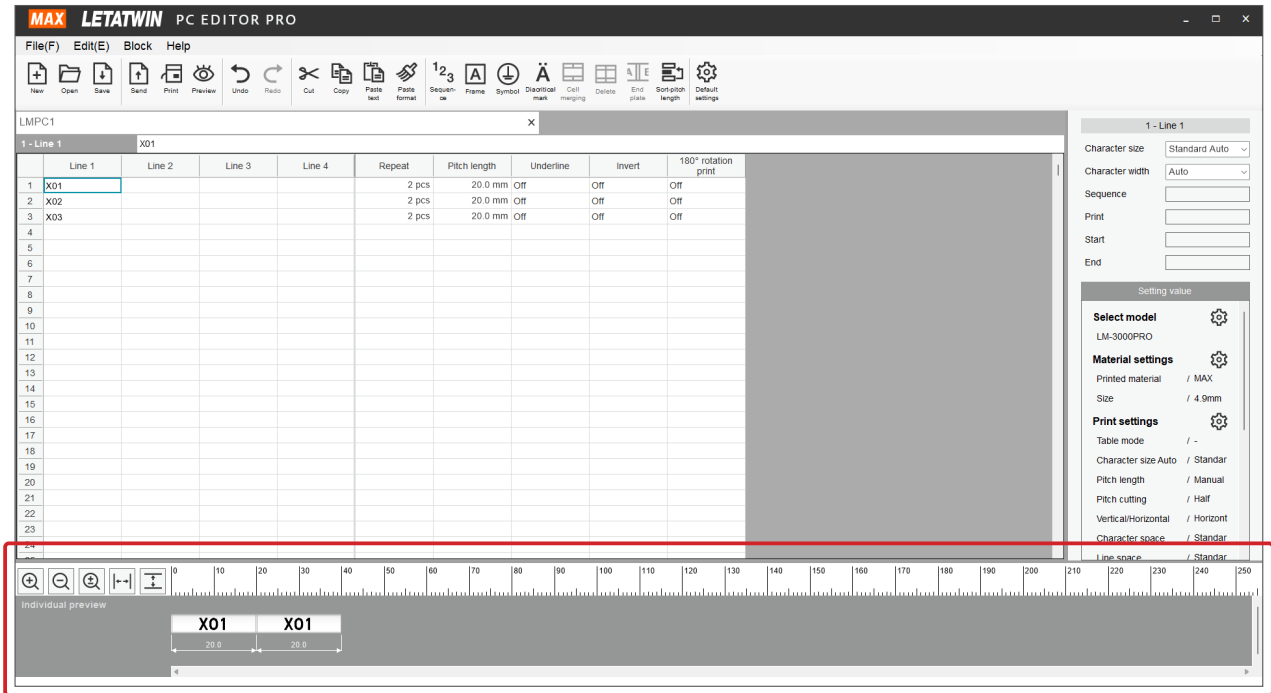

### Preview screen icon operations

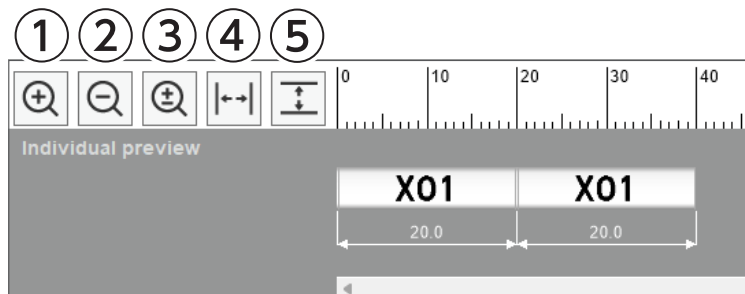

①		Enlarge
②		Shrink
③		Enlarge/Shrink
④		Full view
⑤		Height-based view

#### MEMO

- The pitch length unit shown in individual previews is mm. The display can be switched to inches. [→ 8-8-12 SWITCHING DISPLAYED UNITS BETWEEN MILLIMETERS AND INCHES](#)

## 8-6-2 FULL PREVIEW

- Click "File" - "Full preview" or click the  icon.

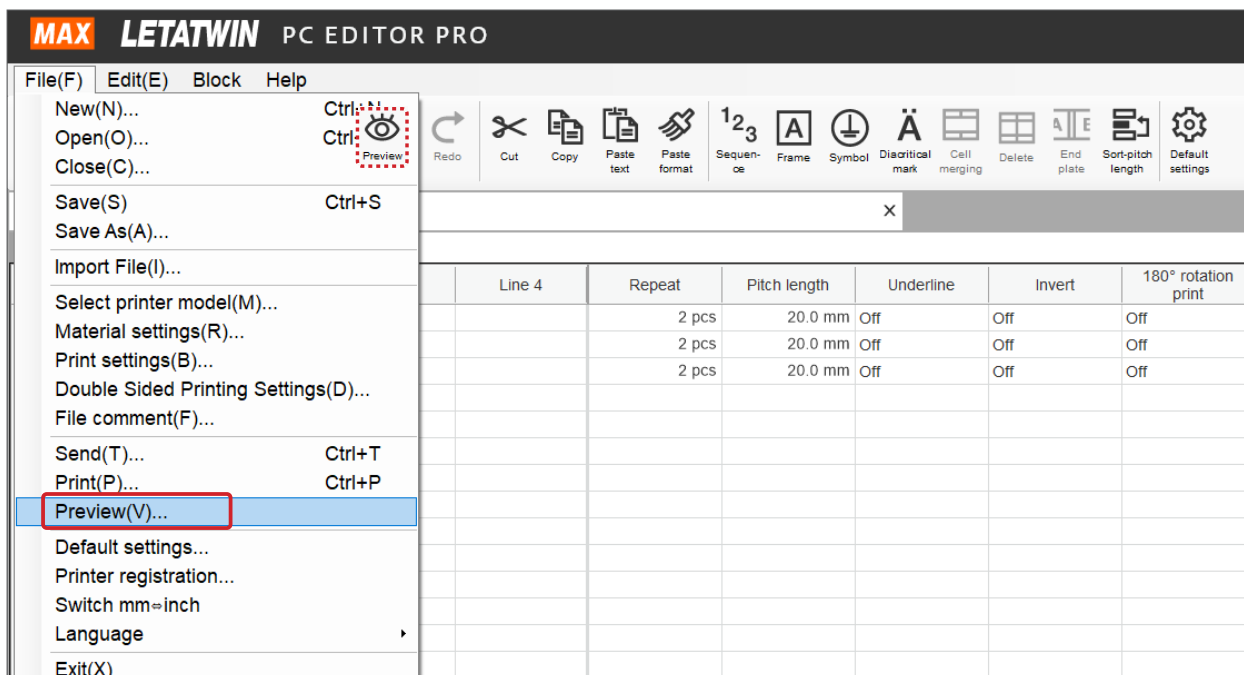

- The full preview is displayed.

On the "Full preview" screen, "Sequence & Repeat" setting, sending and printing can be performed.

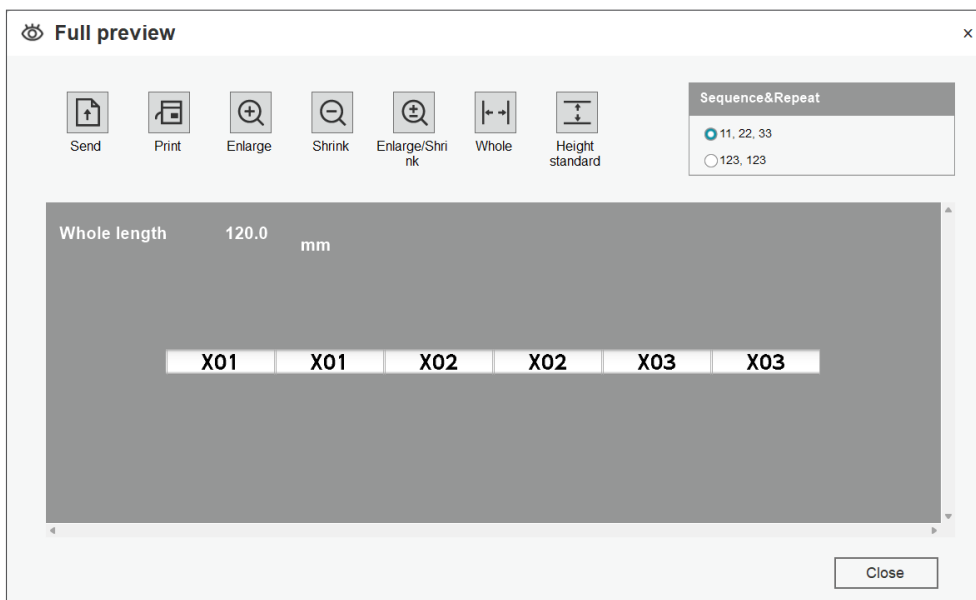

# 8-7 BATCH EDITING OF SETTING VALUES (CHARACTER SIZE, CHARACTER WIDTH, REPEAT, PITCH LENGTH, UNDERLINE, INVERT, 180° ROTATION PRINT)

## 8-7-1 BATCH CHANGES FROM THE EDIT MENU

All setting values for “Character size,” “Character width,” “Repeat,” “Pitch length,” “Underline,” “Invert,” and “180° rotation print” in a document can be changed in a single batch.

Example: Changing the number of repeats from two to four

- 1 Select “Edit” - “Change all,” then click “Repeat.”

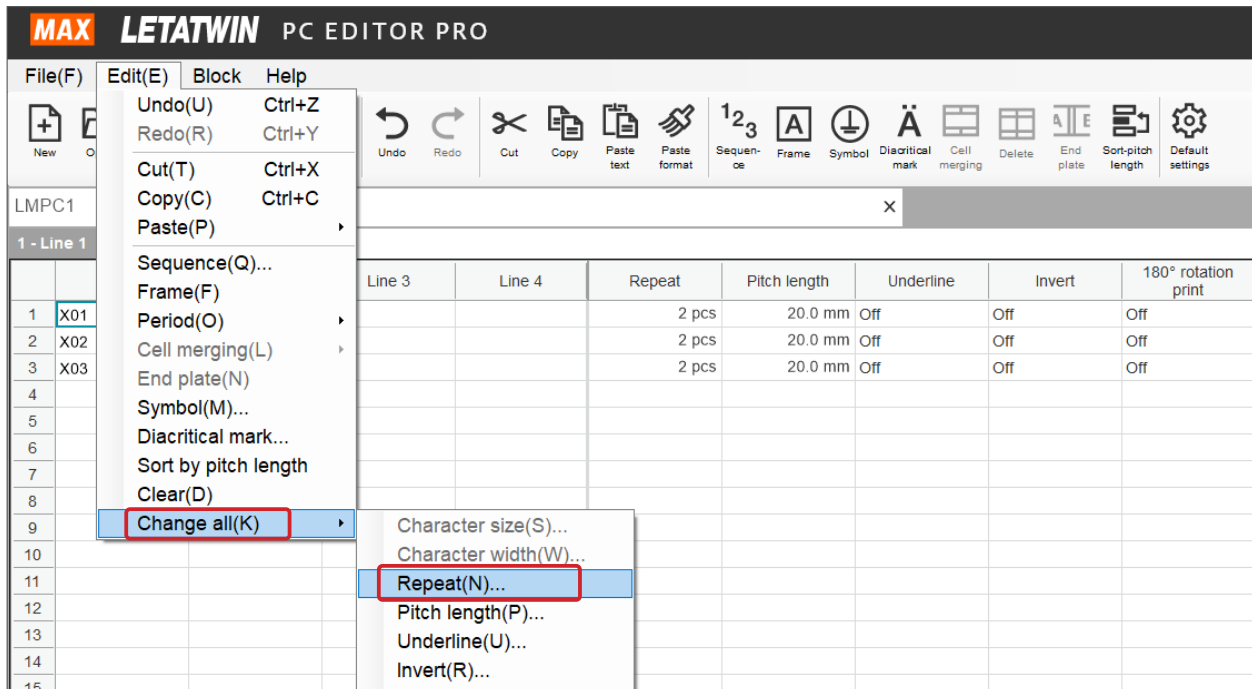

- 2 Press ▲ or enter “4” directly, then click the “OK” button.

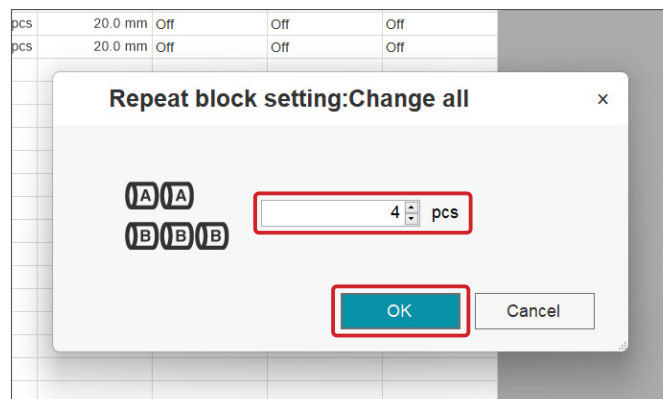

**3** The number of repeats is changed to four.

**MAX LETATWIN PC EDITOR PRO**

File(F) Edit(E) Block Help

New Open Save Send Print Preview Undo Redo Cut Copy Paste text Paste format Sequence Frame Symbol Diacritical mark Cell merging Delete End plate Sort-pitch length Default settings

LMPC1 X

1 - Line 1 X01

	Line 1	Line 2	Line 3	Line 4	Repeat	Pitch length	Underline	Invert	180° rotation print
1	X01				4 pcs	20.0 mm	Off	Off	Off
2	X02				4 pcs	20.0 mm	Off	Off	Off
3	X03				4 pcs	20.0 mm	Off	Off	Off
4									
5									
6									
7									
8									
9									
10									
11									
12									
13									
14									

\*Character size, "Character width," "Repeat," "Pitch length," "Underline," "Invert," and "180° rotation print" can be changed in a batch from "Edit" - "Change all" using the same operation.

**MEMO**

- "Character size" and "Character width" cannot be changed in a batch when "Character Size Auto" in "Print settings" is set to "Standard Auto," "Super Auto" or "Fixed Height Auto." Batch changes can only be applied to "Character size" and "Character width" when "Character Size Auto" is "OFF."

→ 8-1-10 AUTOMATIC CHARACTER SIZE ADJUSTMENT

## 8-7-2 DOUBLE CLICKING TO BATCH CHANGE ITEMS IN LETATWIN PC EDITOR PRO

For five items (“Repeat,” “Pitch length,” “Underline,” “Invert,” and “180° rotation print”), the “Change all” screen can also be displayed by double clicking on the titles shown below.

- 1 Select the item to be changed by double clicking on it. When the dialog box opens, change the content as desired.

	Line 1	Line 2	Line 3	Line 4	Repeat	Pitch length	Underline	Invert	180° rotation print
1	X01				2 pcs	20.0 mm	Off	Off	Off
2	X02				2 pcs	20.0 mm	Off	Off	Off
3	X03				2 pcs	20.0 mm	Off	Off	Off
4									
5									
6									
7									
8									
9									
10									
11									
12									
13									
14									



- To make batch changes to “Character size,” and “Character width,” use “Edit” - “Change all.”

# 8-8 ADVANCED PRINT SETTINGS

## 8-8-1 SELECTING THE MODEL TO PRINT

Multiple LM-3000PRO units can be connected to a single PC for printing. When using with multiple units connected, set the unit to be used for output.

- 1 Click the  icon.

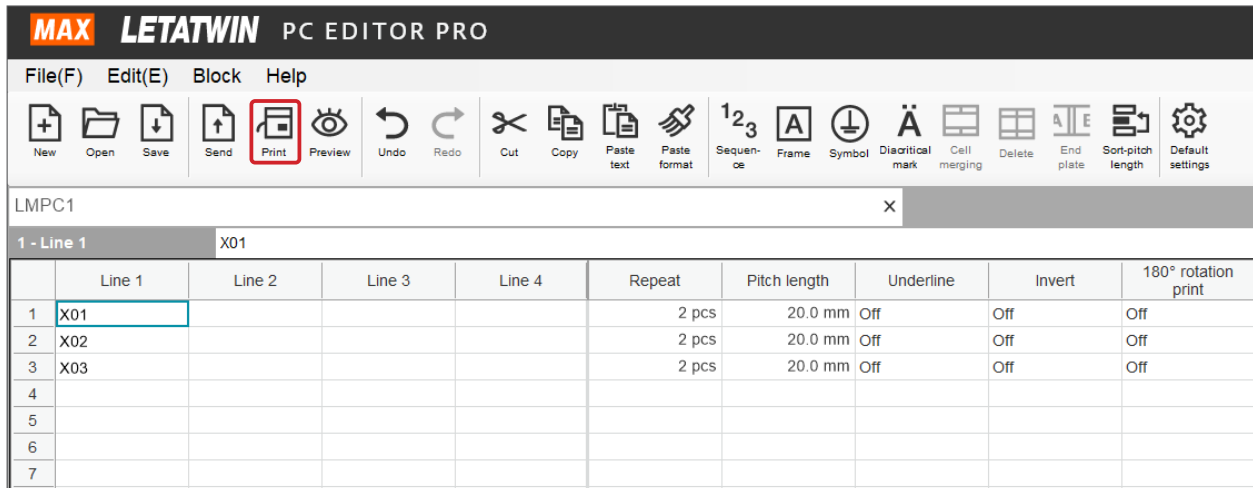

- 2 From "Select Printer," select the printer to be used for output.

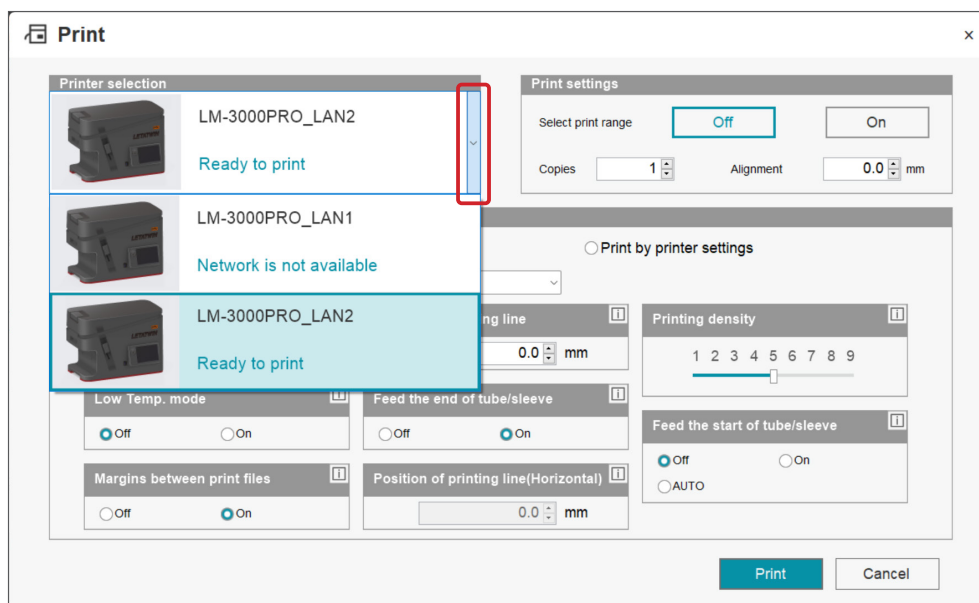

### MEMO

- The LM-3000PRO being used must be registered in LETATWIN PC EDITOR in advance.  
→ 8-8-1 SELECTING THE MODEL TO PRINT
- A single computer cannot be connected to multiple LM-550A3/550A2/550A units.
- Model registration is not required for the LM-550A3/550A2/550A. The set model is applied.
- When using a USB connection, only one computer and one LM-3000PRO can be connected.
- To connect one computer to multiple LM-3000PRO units or multiple computers to one LM-3000PRO, a LAN connection must be used.
- USB connections can be used in conjunction with LAN connections.

## 8-8-2 SELECTING THE PRINT RANGE

With the LM-3000PRO, the print range can be specified for individual blocks.

- 1 Click the  icon.

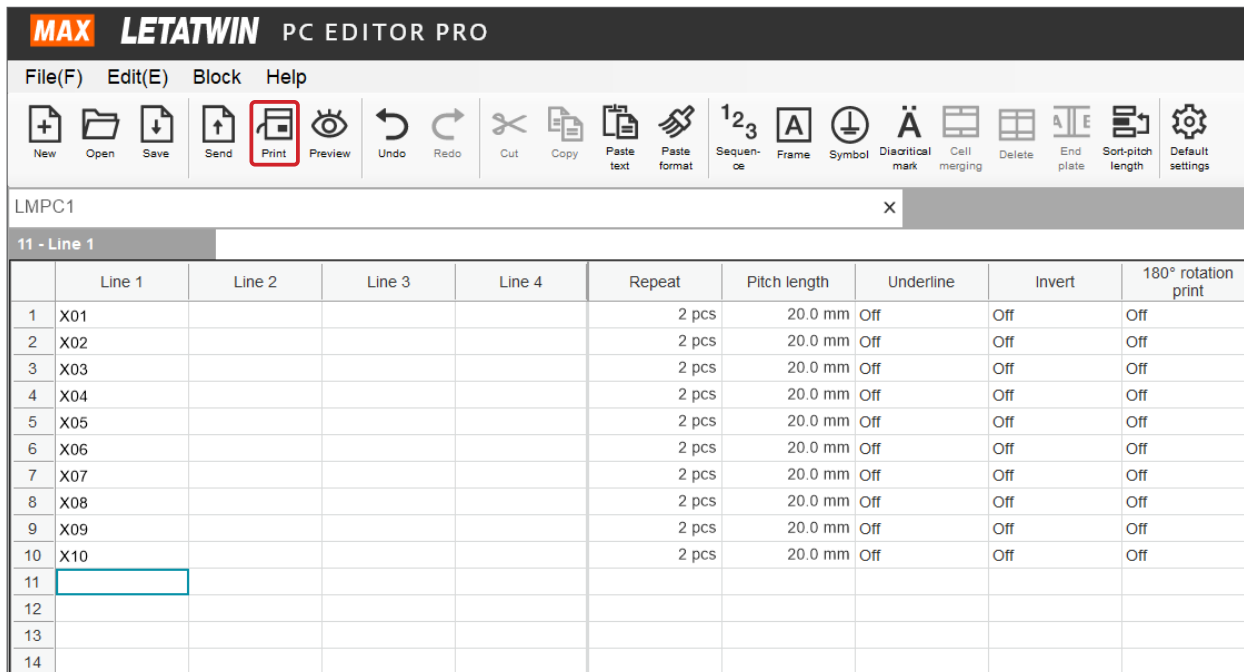

	Line 1	Line 2	Line 3	Line 4	Repeat	Pitch length	Underline	Invert	180° rotation print
1	X01				2 pcs	20.0 mm	Off	Off	Off
2	X02				2 pcs	20.0 mm	Off	Off	Off
3	X03				2 pcs	20.0 mm	Off	Off	Off
4	X04				2 pcs	20.0 mm	Off	Off	Off
5	X05				2 pcs	20.0 mm	Off	Off	Off
6	X06				2 pcs	20.0 mm	Off	Off	Off
7	X07				2 pcs	20.0 mm	Off	Off	Off
8	X08				2 pcs	20.0 mm	Off	Off	Off
9	X09				2 pcs	20.0 mm	Off	Off	Off
10	X10				2 pcs	20.0 mm	Off	Off	Off
11									
12									
13									
14									

- 2 In the “Print settings” field, click the “ON” button under “Select print range.”

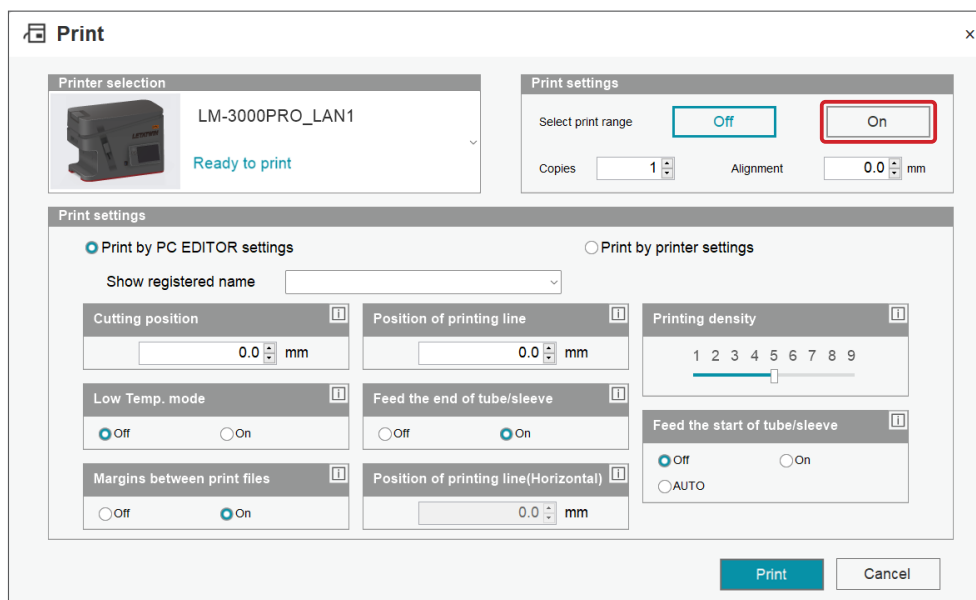

**Print**

Printer selection:  LM-3000PRO\_LAN1  
Ready to print

Print settings

Select print range:

Copies: 1 Alignment: 0.0 mm

Print settings

Print by PC EDITOR settings  Print by printer settings

Show registered name: \_\_\_\_\_

Cutting position: 0.0 mm

Position of printing line: 0.0 mm

Printing density: 1 2 3 4 5 6 7 8 9

Low Temp. mode:  Off  On

Feed the end of tube/sleeve:  Off  On

Margins between print files:  Off  On

Position of printing line(Horizontal): 0.0 mm

Feed the start of tube/sleeve:  Off  On

- 3 Set so that the  icon is present for blocks to be printed, then click the “OK” button and perform printing from the “Print” screen.

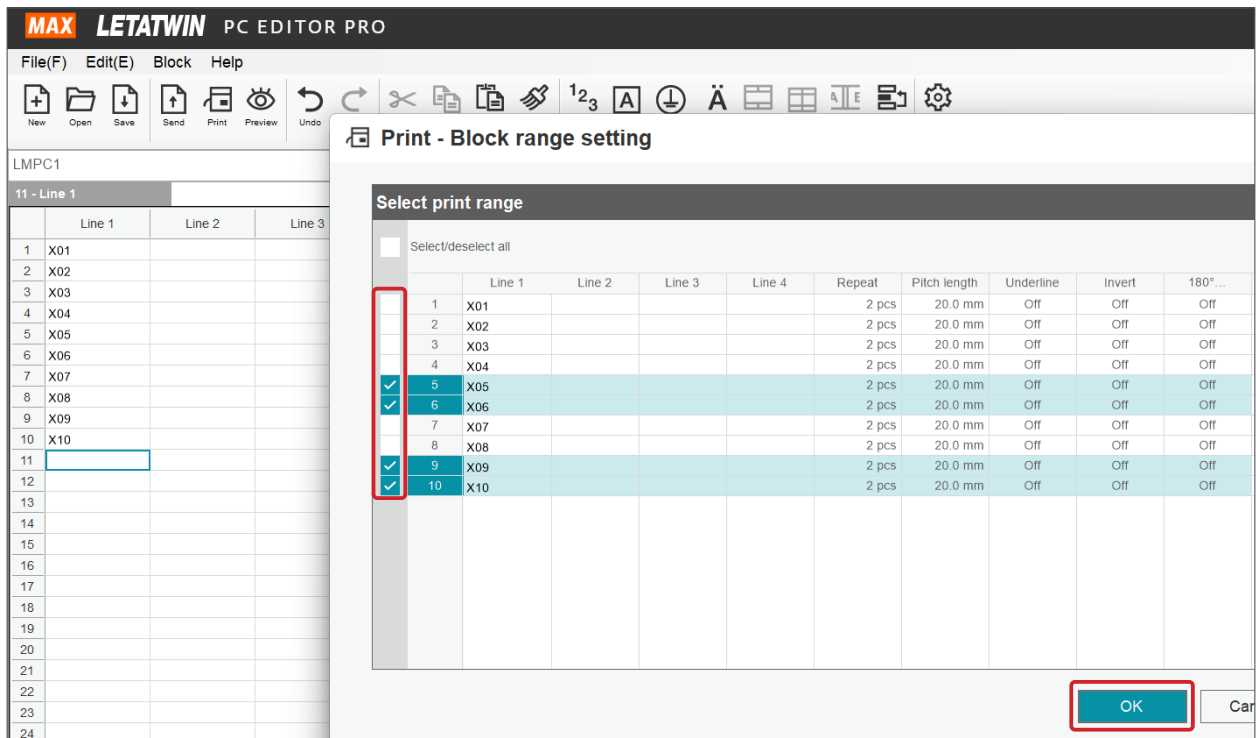

#### MEMO

- When printing using the main unit only, settings cannot be applied to individual blocks.

→ 6-2 PRINTING

- The print range can be specified for individual blocks on the LM-550A3/550A2/550A.
- On the LM-550A3/550A2/550A, the range is specified with “Start No.” and “End No.” blocks.

## 8-8-3 SELECTING THE NUMBER OF PRINT COPIES

The number of copies to be printed can be set. The setting range is from 1 to 30 copies.

- 1 Click the  icon.

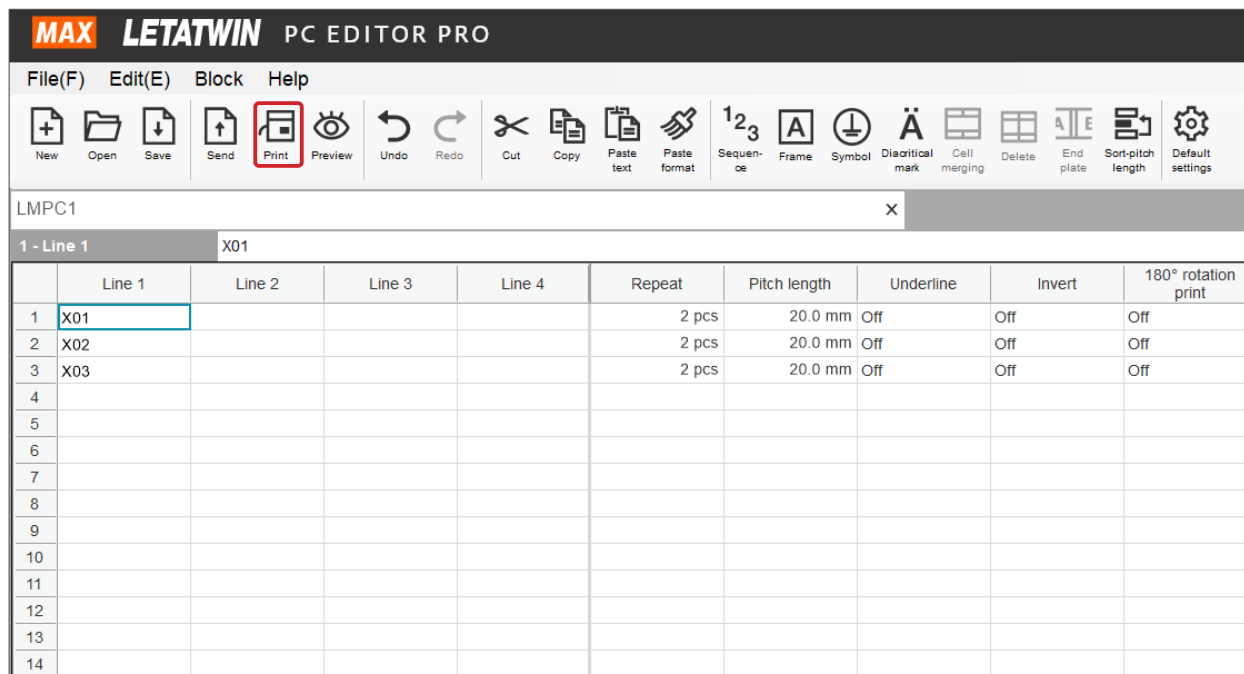

	Line 1	Line 2	Line 3	Line 4	Repeat	Pitch length	Underline	Invert	180° rotation print
1	X01				2 pcs	20.0 mm	Off	Off	Off
2	X02				2 pcs	20.0 mm	Off	Off	Off
3	X03				2 pcs	20.0 mm	Off	Off	Off
4									
5									
6									
7									
8									
9									
10									
11									
12									
13									
14									

- 2 Enter the number of copies, then print.

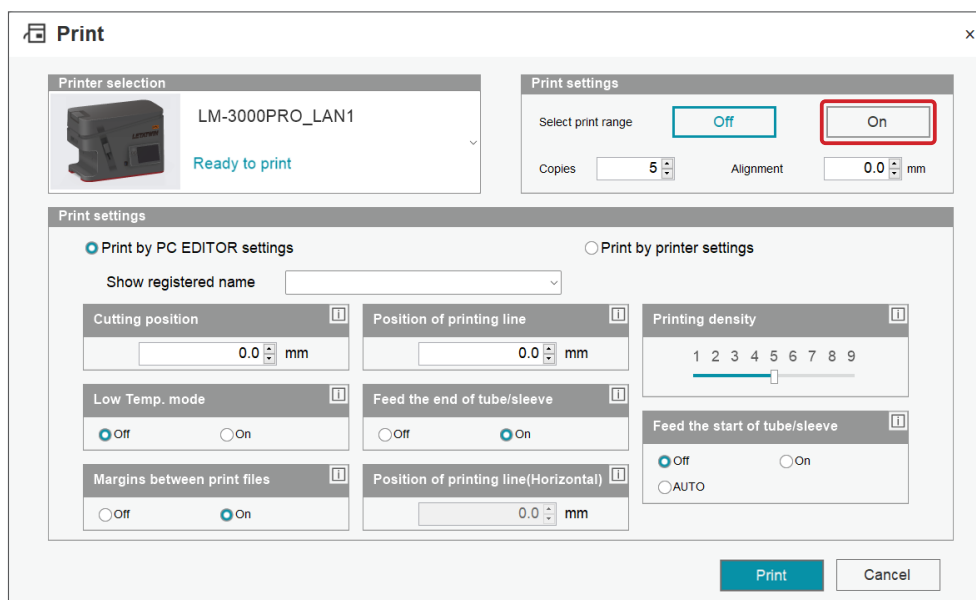

**Print**

Printer selection:  LM-3000PRO\_LAN1  
Ready to print

Print settings

Select print range:

Copies: 5 Alignment: 0.0 mm

Print settings

Print by PC EDITOR settings  Print by printer settings

Show registered name: \_\_\_\_\_

Cutting position: 0.0 mm

Position of printing line: 0.0 mm

Printing density: 1 2 3 4 5 6 7 8 9

Low Temp. mode:  Off  On

Feed the end of tube/sleeve:  Off  On

Margins between print files:  Off  On

Position of printing line(Horizontal): 0.0 mm

Feed the start of tube/sleeve:  Off  On

### MEMO

- The number of copies can also be set when printing from the main unit.  
→ 6-2 PRINTING
- The presence or absence of margins between print files can only be set on the LM-3000PRO.

## 8-8-4 PRINT ALIGNMENT

When the actual print length differs from the set length, the overall print material length can be adjusted before printing.

For the alignment value, enter the difference between the actual print length and the set length.

Setting range	
Actual print length is shorter than the set length	Enter a positive adjustment value.
Actual print length is longer than the set length	Enter a negative adjustment value.

**1** Click the  icon.

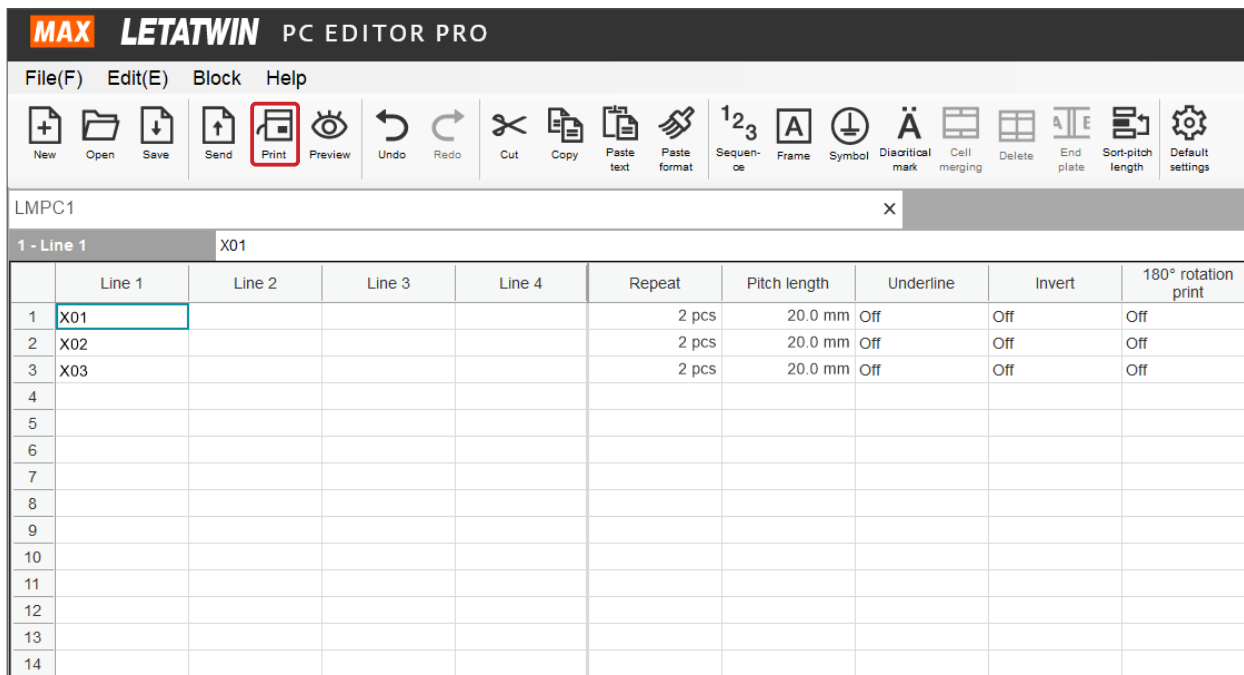

**2** Enter the adjustment value in the “Alignment” field, then print.

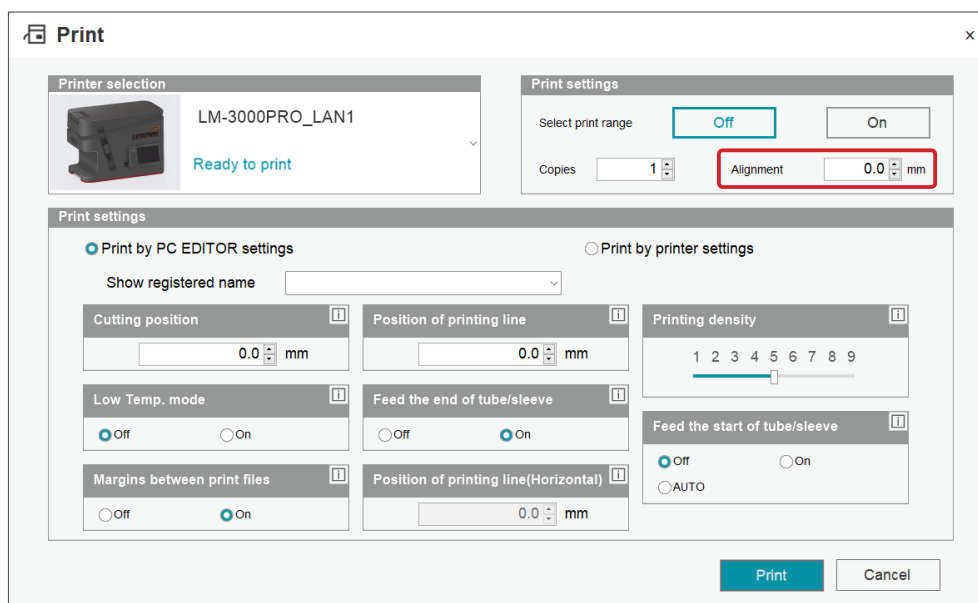

## 8-8-5 SEPRATING MAIN PRINTER UNIT AND LETATWIN PC EDITOR PRO SETTINGS AND PRINTING FROM LETATWIN PC EDITOR PRO

Printing with PC EDITOR settings	Setting values set on printer are temporarily applied and printing is performed.
Printing with main printer unit settings	Setting values set on PC EDITOR are temporarily applied and printing is performed.

Setting items temporarily applied for LM-3000PRO printing and applicable setting ranges

Setting item	Setting range	
Cutting position	-2.0mm to +2.0mm	
Low temperature mode	OFF/ON	
Margins between print files	OFF/ON	
Printing line position	-3.8mm to +3.8mm	
Post-print feed	OFF/ON	
Horizontal printing line position	0mm to 8.0mm	
Printing density	1 to 9	
Pre-print feed	OFF/ON/AUTO	

1 Click the  icon.

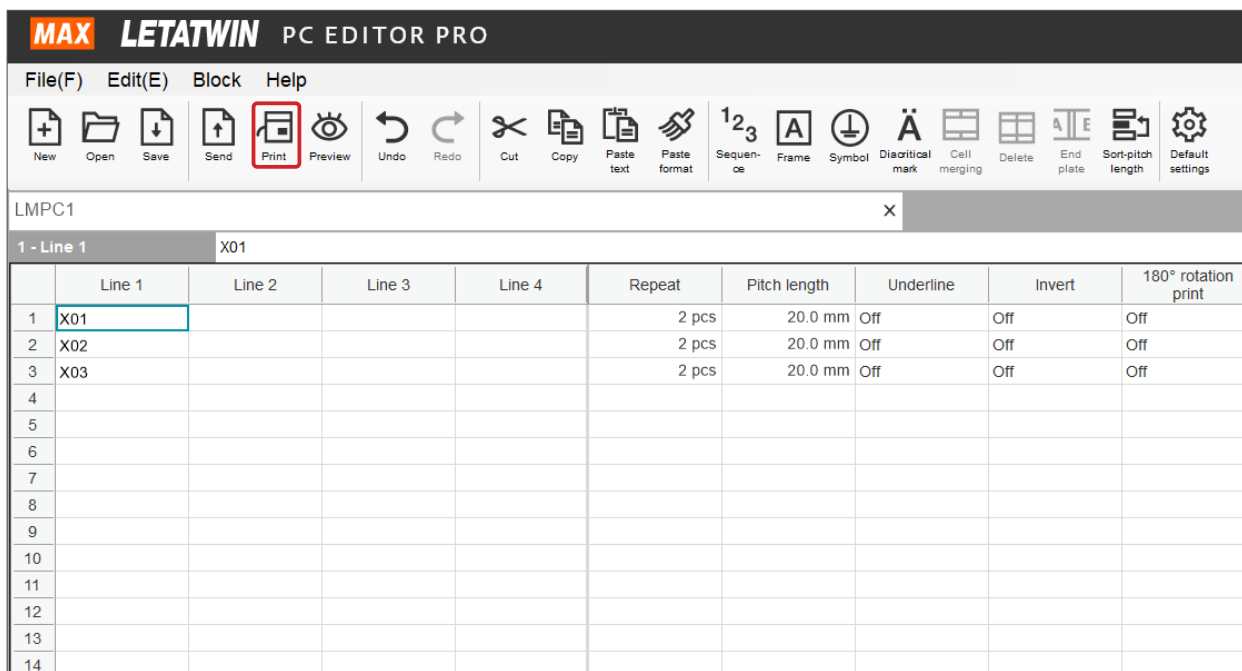

**MAX LETATWIN PC EDITOR PRO**

File(F) Edit(E) Block Help

New Open Save Send **Print** Preview Undo Redo Cut Copy Paste text Paste format Sequence Frame Symbol Diacritical mark Cell merging Delete End plate Sort-pitch length Default settings

LMPC1

Line 1	Line 2	Line 3	Line 4	Repeat	Pitch length	Underline	Invert	180° rotation print
X01				2 pcs	20.0 mm	Off	Off	Off
X02				2 pcs	20.0 mm	Off	Off	Off
X03				2 pcs	20.0 mm	Off	Off	Off

- 2** Select either “Print by main printer unit settings” or “Print by PC EDITOR settings.”

The screenshot shows the 'Print' dialog box for the LM-3000PRO\_LAN1 printer. The printer is in a 'Ready to print' state. The 'Print settings' section at the top right shows 'Select print range' set to 'Off', 'Copies' set to 1, and 'Alignment' set to 0.0 mm. The main 'Print settings' section has two radio buttons: 'Print by PC EDITOR settings' (which is selected and highlighted with a red box) and 'Print by printer settings'. Below these are several configuration options: 'Show registered name' (dropdown), 'Cutting position' (0.0 mm), 'Position of printing line' (0.0 mm), 'Printing density' (slider from 1 to 9), 'Low Temp. mode' (Off), 'Feed the end of tube/sleeve' (On), 'Feed the start of tube/sleeve' (Off), 'Margins between print files' (On), and 'Position of printing line(Horizontal)' (0.0 mm). 'Print' and 'Cancel' buttons are at the bottom right.

- 3** When “Print by PC EDITOR settings” is selected, previously-registered settings can be recalled and used. → 8-9-3 REGISTERING PRINT PARAMETER SETTINGS

This screenshot is identical to the one above, showing the 'Print' dialog box with 'Print by PC EDITOR settings' selected. In this version, the 'Show registered name' dropdown menu is highlighted with a red box, indicating that users can select from previously registered settings.

**MEMO**

- With the LM-550A3/550A2/550A, separate settings cannot be used for the main printer unit settings and PC EDITOR PRO. The PC EDITOR settings are applied.
- On the LM-550A3/550A2/550A, “Cutting position,” “Low temperature mode,” “Position of printing line,” “Pre-print feed” and “Printing density” are the only items that can be set.

## 8-8-6 SETTING THE CUTTING POSITION

Moving the cutting position adjusts the printing position.

If the print position is shifted too far to the right, use a positive setting. If it is shifted too far to the left, use a negative setting.

Setting range	+	:	COM	→	COM
-2.0 to +2.0mm	-	:	COM	→	COM

1 Click the  icon.

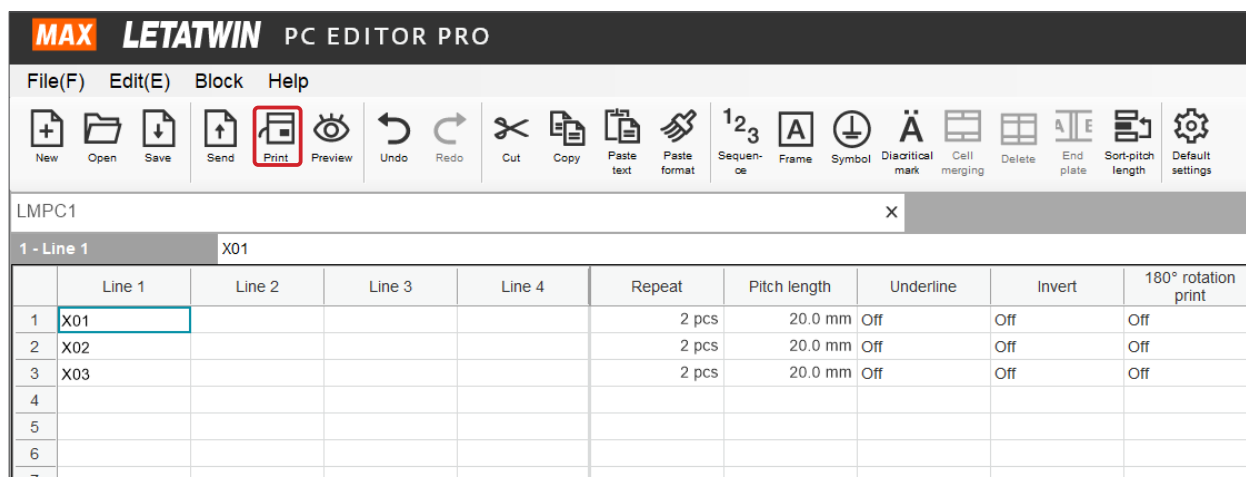

	Line 1	Line 2	Line 3	Line 4	Repeat	Pitch length	Underline	Invert	180° rotation print
1	X01				2 pcs	20.0 mm	Off	Off	Off
2	X02				2 pcs	20.0 mm	Off	Off	Off
3	X03				2 pcs	20.0 mm	Off	Off	Off
4									
5									
6									
7									

2 Enter an adjustment value under “Cutting position.”

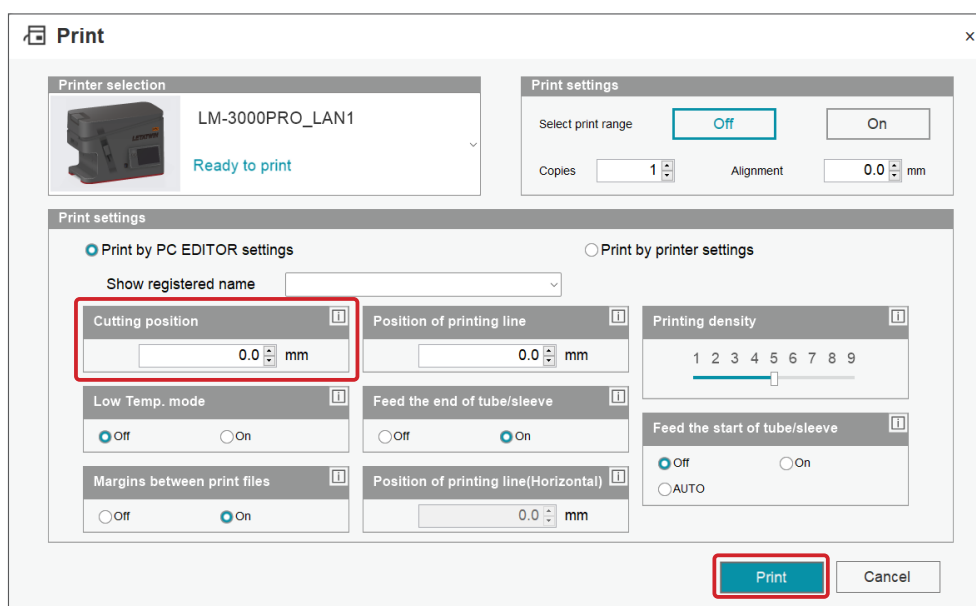

### MEMO

- The entered cutting position value can be registered, then recalled for use from the “Reference registered information” field.

→ 8-9-3 REGISTERING PRINT PARAMETER SETTINGS

## 8-8-7 SETTING THE PRINTING LINE POSITION

If the print position has shifted vertically, adjust the vertical position before printing.

Positive setting values move the print position up, negative values move the print position down.

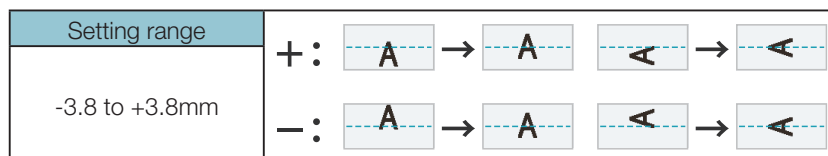

1 Click the  icon.

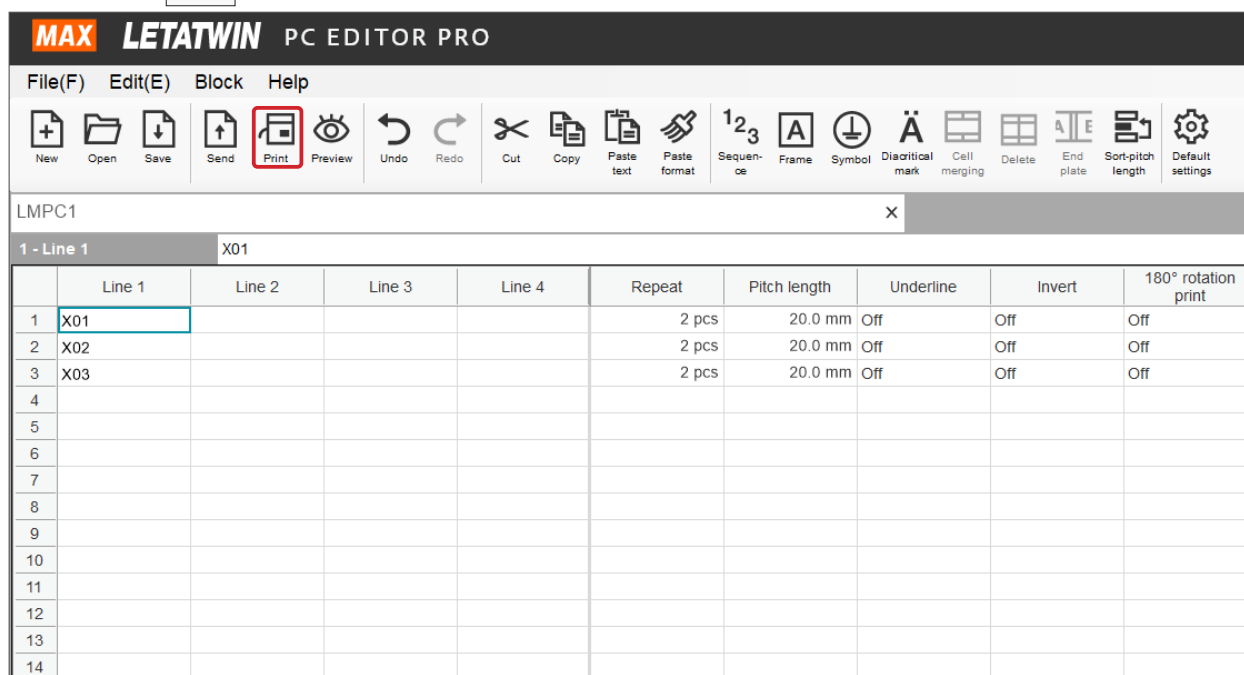

2 Change the setting value under “Position of printing line” on the “Print” screen.

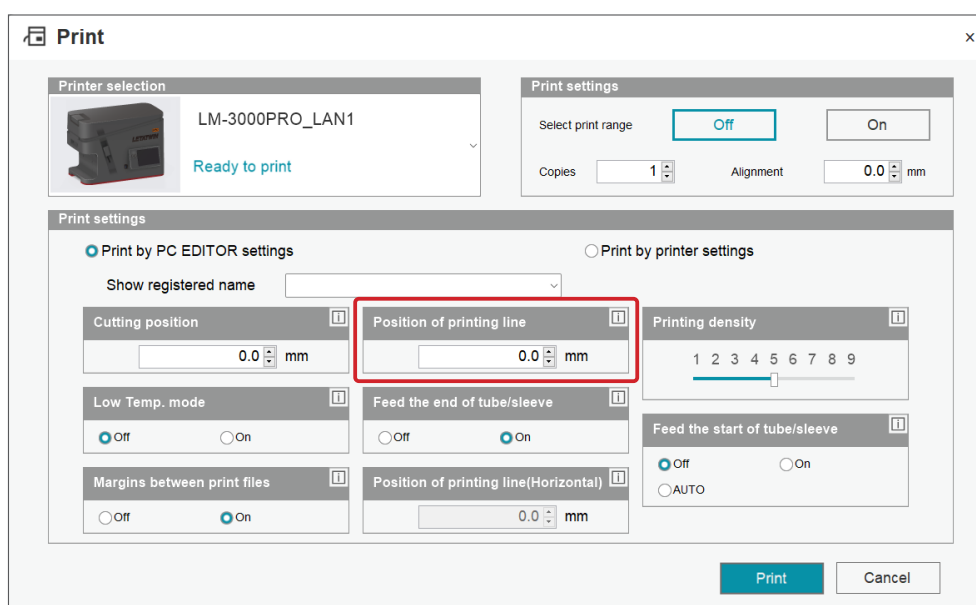

- The “Position of printing line” setting can be registered as a default setting (initial value).

→ 8-9 REGISTERING DEFAULT SETTINGS (INITIAL VALUES)

## 8-8-8 SETTING POST-PRINT FEEDING

When this setting is turned ON, after printing, the print material is fed up to the main unit's print material outlet. To reduce the post-print margin on the print material, set this to "OFF."

ON:



1 Click the  icon.

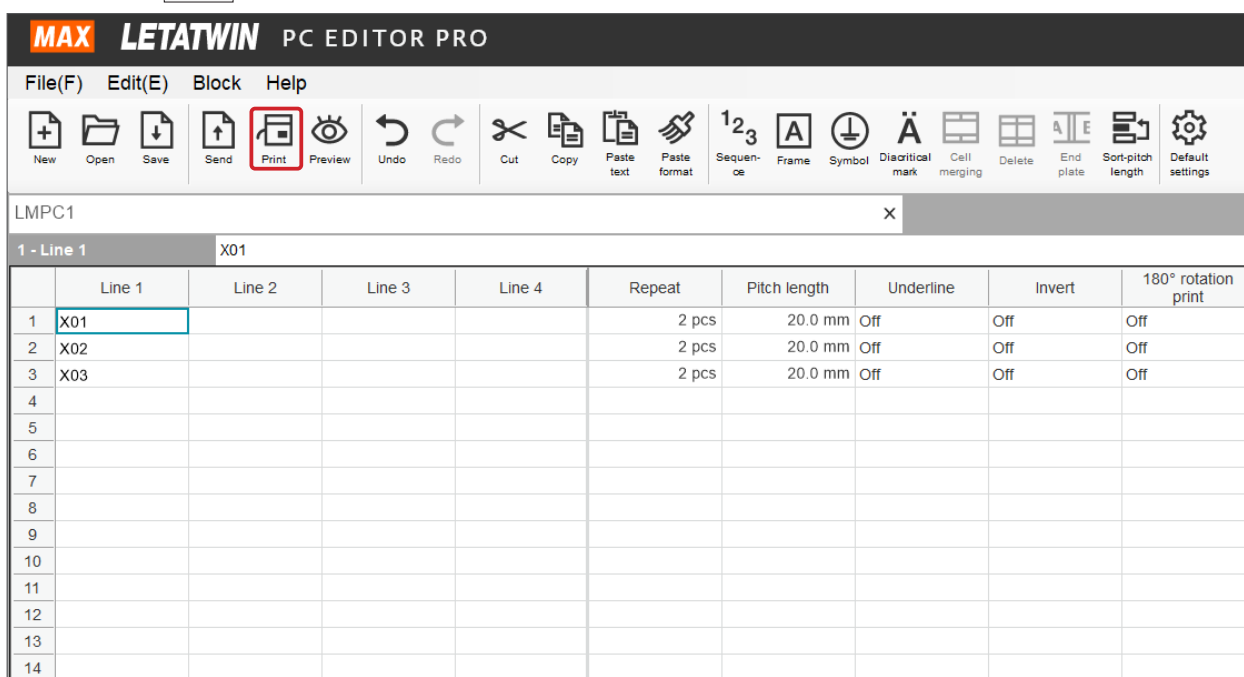

2 Under "Post-print feed" on the "Print" screen, select "ON" or "OFF," then perform printing.

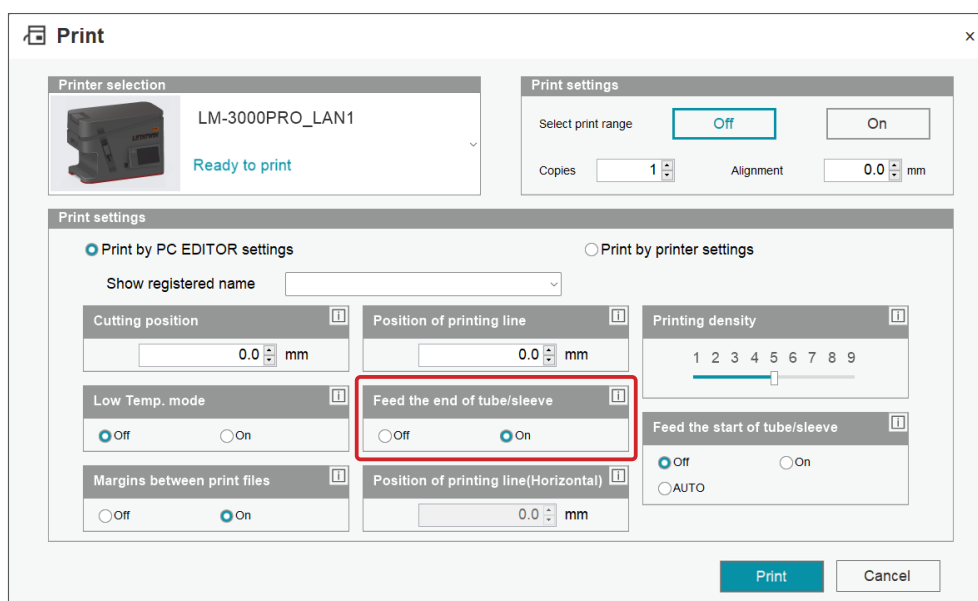

**MEMO**

- The “Post-print feed” setting can be registered as a default setting.  
→ 8-9 REGISTERING DEFAULT SETTINGS (INITIAL VALUES)
- The amount of post-print feed is fixed to “ON” when double-sided printing is set to “ON.”  
Setting restrictions when double-sided printing is set to “ON” are as follows.

Function	Function restrictions
Select print range	Setting permitted
Copies	Fixed at “1,” grayed out
Alignment	Fixed at “0,” grayed out
Cutting position	Setting permitted
Printing line position	Setting permitted
Printing density	Setting permitted
Low temperature mode	Setting permitted
Pre-print feed	Fixed at “OFF,” grayed out
Post-print feed	Fixed at “ON,” grayed out
Margins between print files	Fixed at “OFF,” grayed out
Horizontal printing line position	Fixed at “0,” grayed out

## 8-8-9 PRE-PRINT FEEDING

In low temperatures, such as during winter, tubes and grip sleeves may harden, causing the printing on the first two or three items to become blurred or faint.

Printing while the feeding of print material is unstable can cause printing to become blurred or faint.

To provide more stable feeding and ensure print quality, a certain amount of the print material should be fed through. To do so, set “Pre-print feed” to “ON” or “AUTO”, then perform printing.

ON :  COM | A01 | A02 | A03

OFF:  COM | A01 | A02 | A03 | A04 | A05

“AUTO,” automatically switches between “Pre-print feed” - “ON” when printing after opening the main unit door cover and “Pre-print feed” - “OFF” when printing without opening the door cover.

**1** Click the  icon.

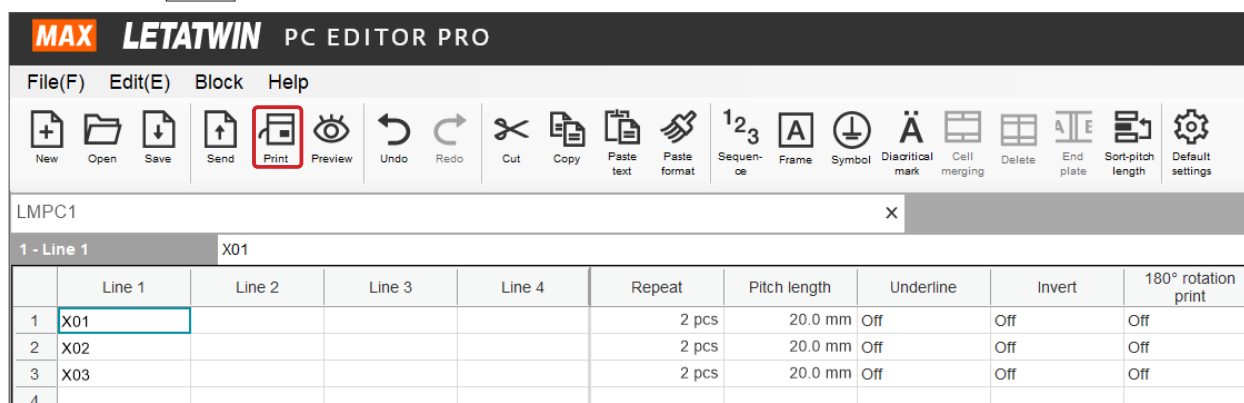

**2** Set “Pre-print feed” on the “Print” screen, then print.

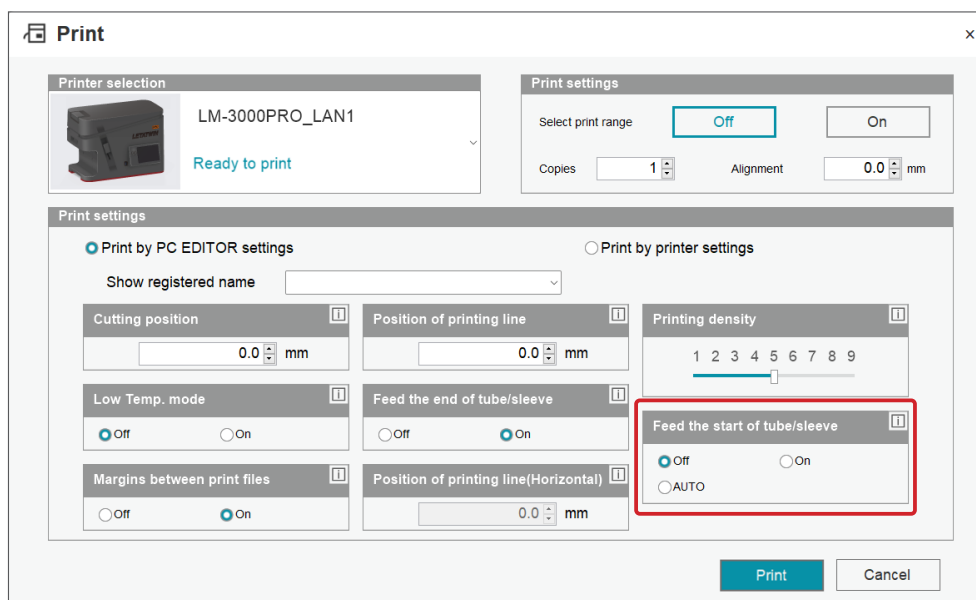

### MEMO

- For print materials for which full cutting is supported (materials other than marker strips and block markers), even when “Pre-print feed” and “Post-print feed” are set to “OFF,” the print material is transported to the full cutting position. As a result, a margin of a certain size is produced.
- The “Pre-print feed” setting can be registered as a default setting.

[→ 8-9 REGISTERING DEFAULT SETTINGS \(INITIAL VALUES\)](#)

## 8-8-10 SETTING MARGINS BETWEEN PRINT FILES

This sets the margins between print files when multiple copies are being printed. Set this to “ON” to insert margins between print files.

OFF	No margin	
ON	10mm One block for block markers	

- 1 Click the  icon.

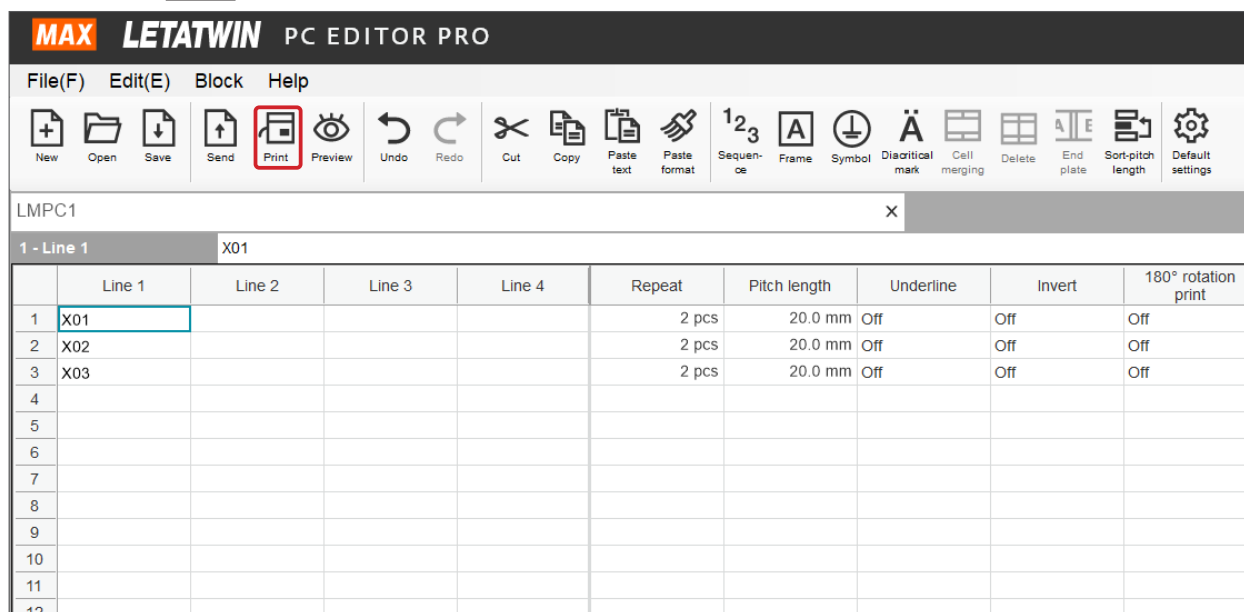

	Line 1	Line 2	Line 3	Line 4	Repeat	Pitch length	Underline	Invert	180° rotation print
1	X01				2 pcs	20.0 mm	Off	Off	Off
2	X02				2 pcs	20.0 mm	Off	Off	Off
3	X03				2 pcs	20.0 mm	Off	Off	Off
4									
5									
6									
7									
8									
9									
10									
11									
12									

- 2 On the “Print” screen, set “Margins between print files” to “ON” or “OFF”, then print.

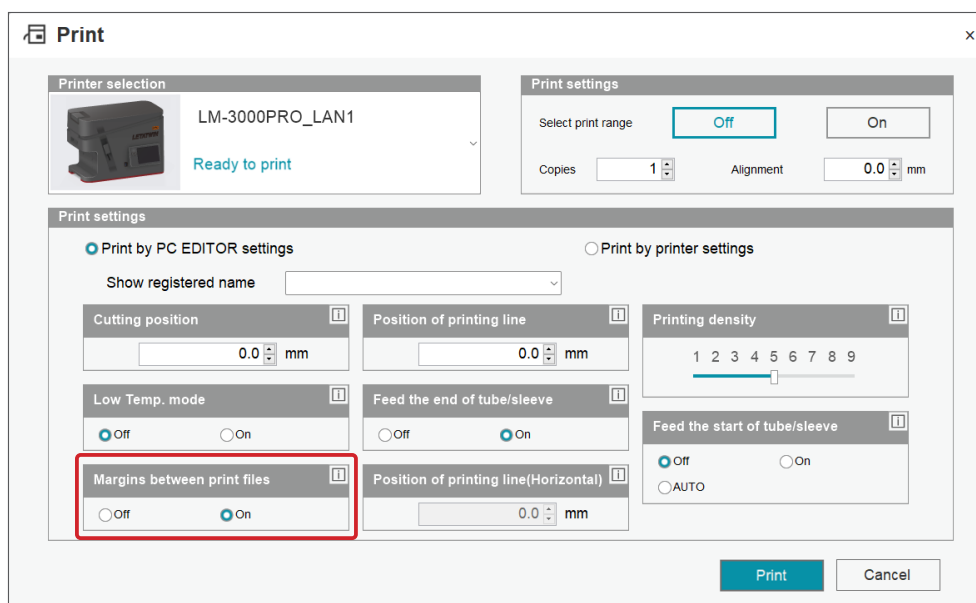

**Print**

Printer selection: LM-3000PRO\_LAN1 (Ready to print)

Print settings:



- Select print range:
- Copies: 1
- Alignment: 0.0 mm

Print settings:

- Print by PC EDITOR settings
- Print by printer settings
- Show registered name: [Dropdown]
- Cutting position: 0.0 mm
- Position of printing line: 0.0 mm
- Printing density: [Slider 1-9]
- Low Temp. mode:  Off  On
- Feed the end of tube/sleeve:  Off  On
- Feed the start of tube/sleeve:  Off  On
- Margins between print files:  Off  On
- Position of printing line(Horizontal): 0.0 mm

## 8-8-11 ADJUSTING THE HORIZONTAL PRINTING LINE POSITION (BLOCK MARKERS ONLY)

This adjusts the horizontal position of the printing line for block markers. Higher numbers move text further to the right.

Setting range		
0.0 to +8.0mm	Position shifted left of center + : 	Enter a setting value to align with the center of the block.
	Position shifted right of center + : 	Enter a setting value to align with the center of the next block.

1 Click the  icon.

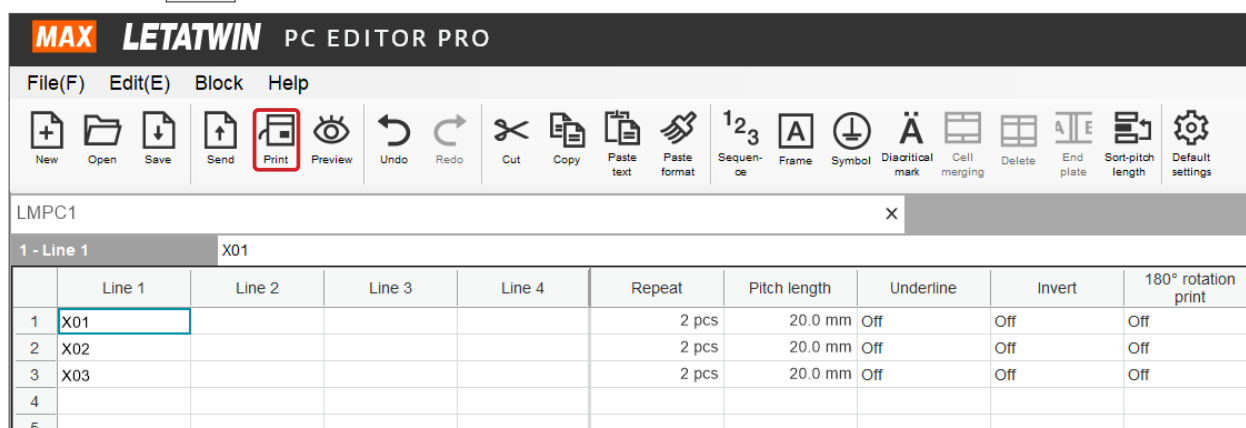

2 On the “Print” screen, enter a value for “Position of printing line (Horizontal),” then print.

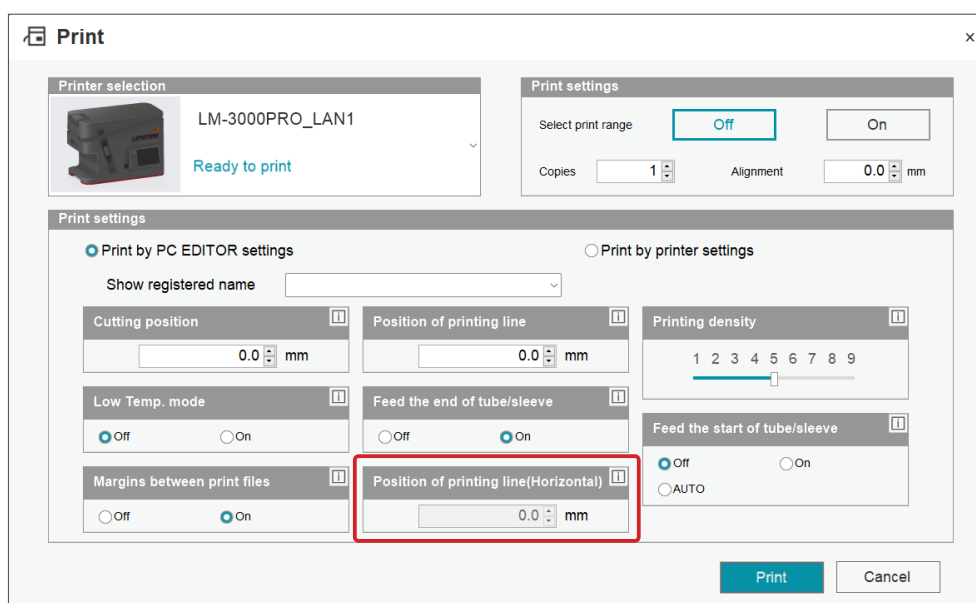

### MEMO

- To adjust the horizontal printing line position for print materials other than block markers, use the “Cutting position” setting on the same screen.
- The “Position of printing line (Horizontal)” setting can be registered as a default setting.

→ 8-9 REGISTERING DEFAULT SETTINGS (INITIAL VALUES)

## 8-8-12 SWITCHING DISPLAYED UNITS BETWEEN MILLIMETERS AND INCHES

- 1 Click "File" - "Switch mm↔inch."

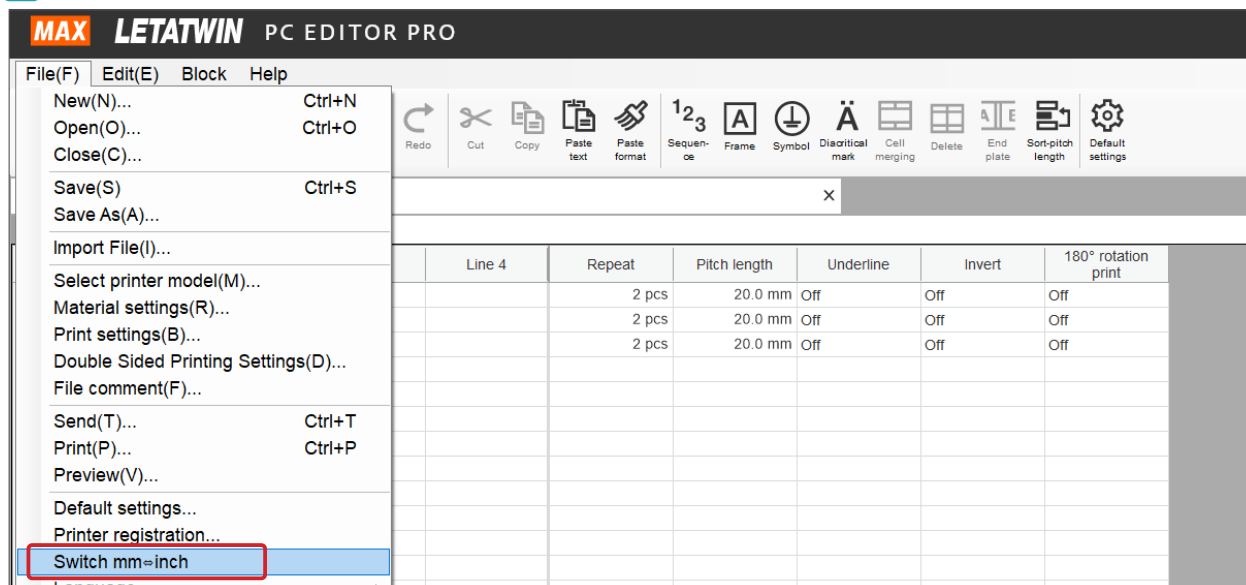

- 2 The length unit switches to inches.

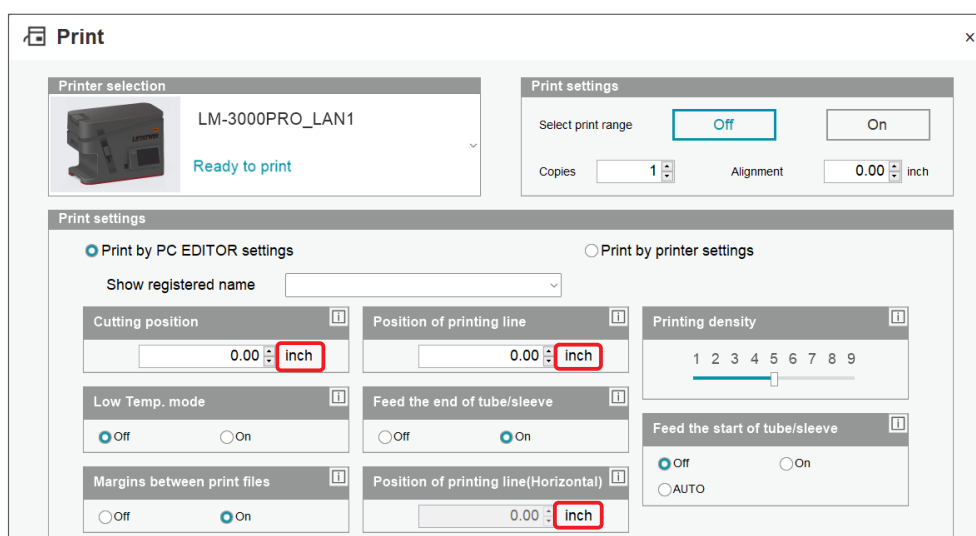
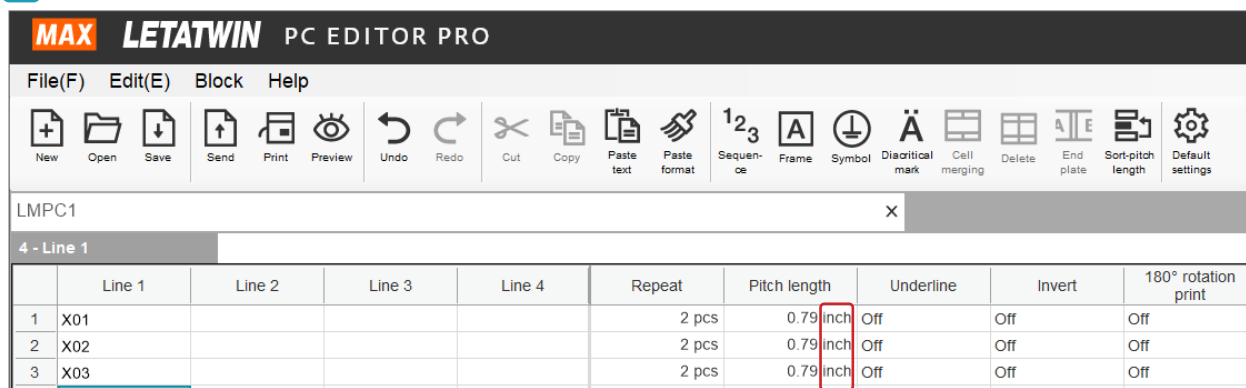

### MEMO

- Millimeters are displayed even when the material size setting is changed to inches.
- Switching between millimeters and inches multiple times can cause the error to increase. Set to millimeters or inches when using LETATWIN PC EDITOR PRO for the first time, then avoid switching the setting as far as possible.

# 8-9 REGISTERING DEFAULT SETTINGS (INITIAL VALUES)

Settings can be registered as default settings (initial values).  
The default setting values are applied when creating a new document.

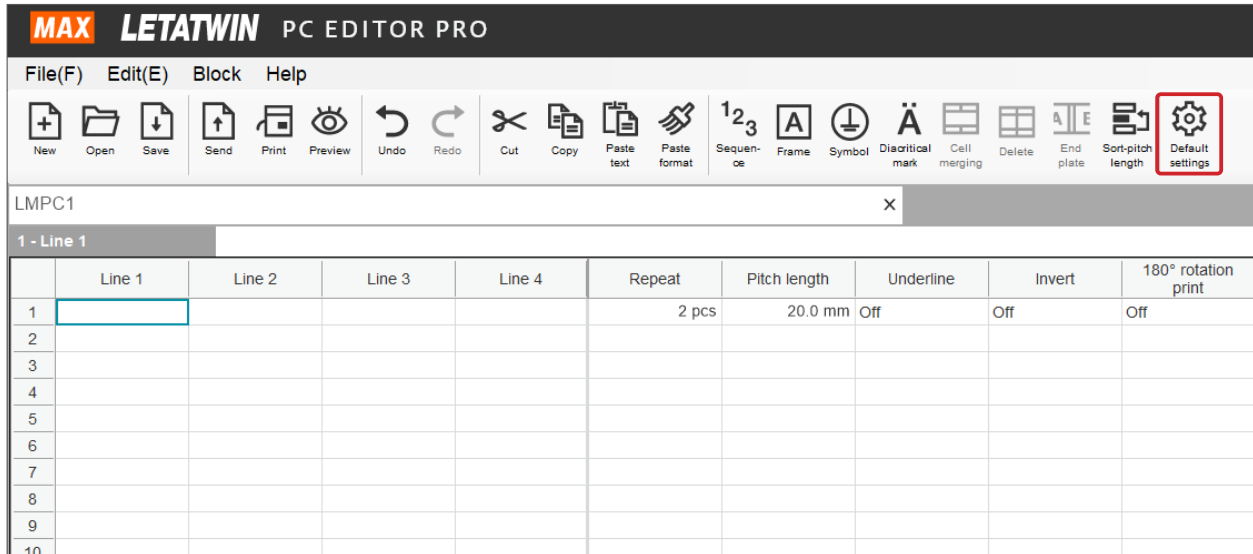

- 1 To open the “Default settings” screen, click the  icon.

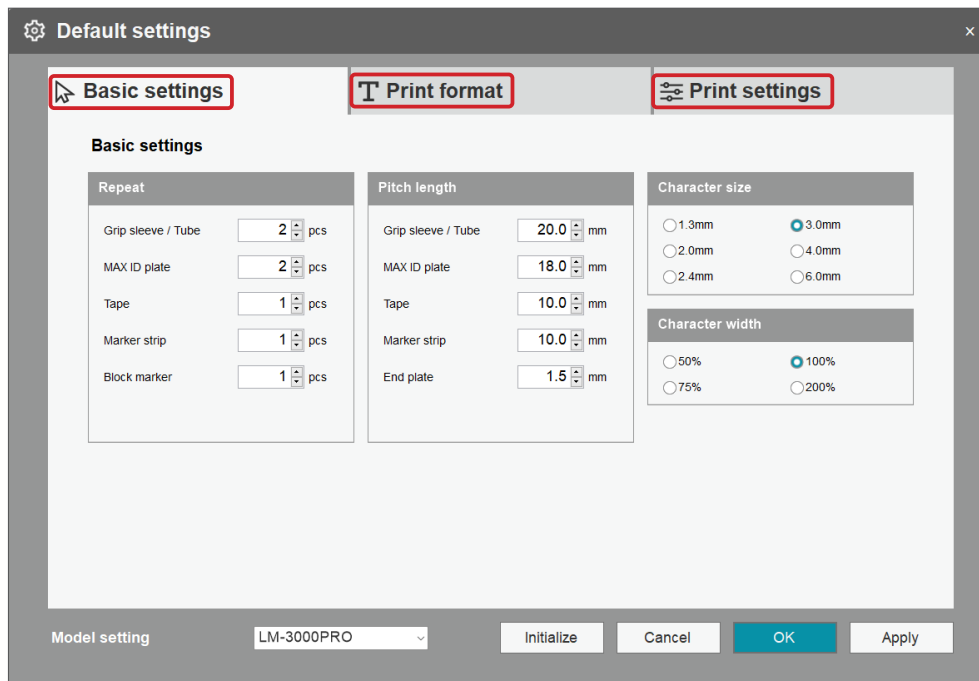

- 2 As shown below, three types of settings (“Basic settings,” “Print settings” and “Print parameter settings”) can be set in “Default settings.”

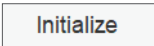

With the LM-3000 PRO/LM-550A3/550A2/550A, default setting values can be registered for each model.

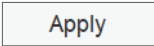
	Initializes the settings for the set model only.
	Closes the “Default settings” screen without applying the setting values.
	Applies the setting values and closes the “Default settings” screen.
	Applies the setting values without closing the “Default settings” screen.

## 8-9-1 REGISTERING BASIC SETTINGS

Default settings (initial values) can be set for “Repeat,” “Pitch length,” “Character size,” and “Character width.”

Default settings dialog box, Basic settings tab. The 'Basic settings' tab is highlighted with a red box. The settings are as follows:

Repeat	Pitch length	Character size	Character width
Grip sleeve / Tube: 2 pcs	Grip sleeve / Tube: 20.0 mm	1.3mm, 2.0mm, 2.4mm, 3.0mm (selected), 4.0mm, 6.0mm	50%, 75%, 100% (selected), 200%
MAX ID plate: 2 pcs	MAX ID plate: 18.0 mm		
Tape: 1 pcs	Tape: 10.0 mm		
Marker strip: 1 pcs	Marker strip: 10.0 mm		
Block marker: 1 pcs	End plate: 1.5 mm		

### MEMO

- “Character size” and “Character width” settings are only applied when “Character Size Auto” on the “Print settings” screen is set to “OFF.”
- Default setting values can be registered for each model.

## 8-9-2 REGISTERING PRINT SETTINGS

Settings for items on the “Print settings” screen can be registered as default settings (initial values).

Default settings dialog box, Print format tab. The 'Print format' tab is highlighted with a red box. The settings are as follows:

Table mode	Pitch length	Character Size Auto	Pitch cutting	Vertical/Horizontal	Character space	Line space	Font choices	6.9MARK	Zeroslash	Frame	Sequence&Repeat
Off (selected), On	Auto, Manual (selected)	Standard Auto (selected), Super Auto, Fixed Height Auto, Off	Half cutting (selected), Dots, Line, Off	Horizontal (selected), Vertical	Standard (selected), Contact, Close, Wide	Standard (selected), Contact, Close, Wide	Clear font (selected), Fine, Vietnamese, Standard, Square font	Off (selected), Dots, Underline	Off (selected), On	Off (selected), On, Standard	11, 22, 33 (selected), 123, 123

### MEMO

- Default setting values can be registered for each model.
- Setting items that are grayed out and cannot be input cannot be used with the model in question.

## 8-9-3 REGISTERING PRINT PARAMETER SETTINGS

For “Print parameter settings,” changed setting values can be named and saved to be recalled for later printing.

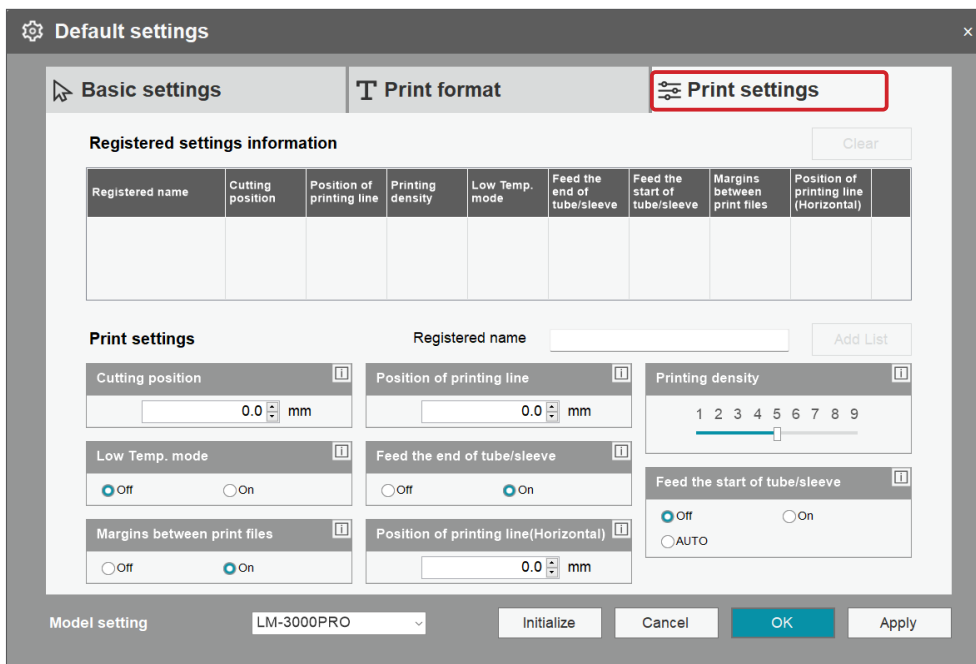

- 1 After entering setting values, enter the name to be registered, then click “Add List.”

Example: Registering a cutting position of 1.0mm

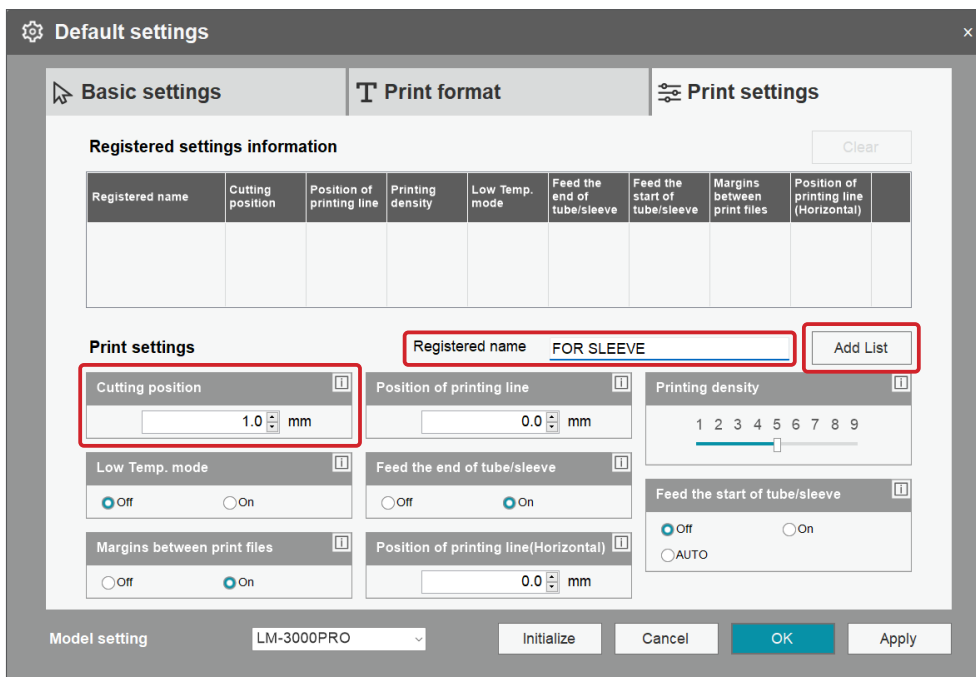

**2** The setting values have been registered.

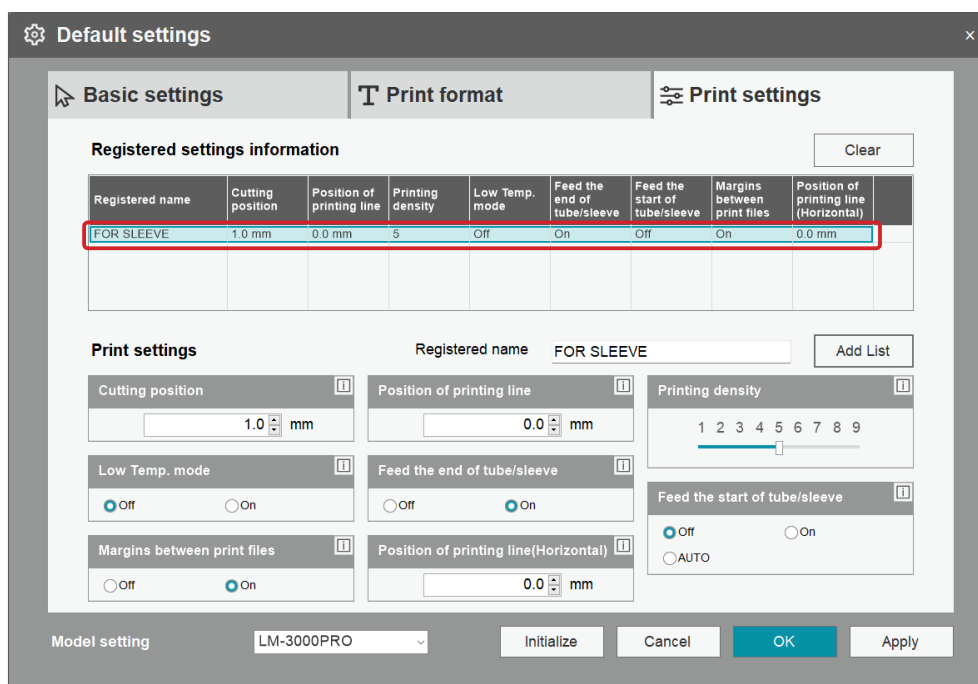

**3** On the “Print” screen, select “Print with PC EDITOR settings”, recall settings using “Show registered name,” then print.

Cutting position: 1.0mm is applied.

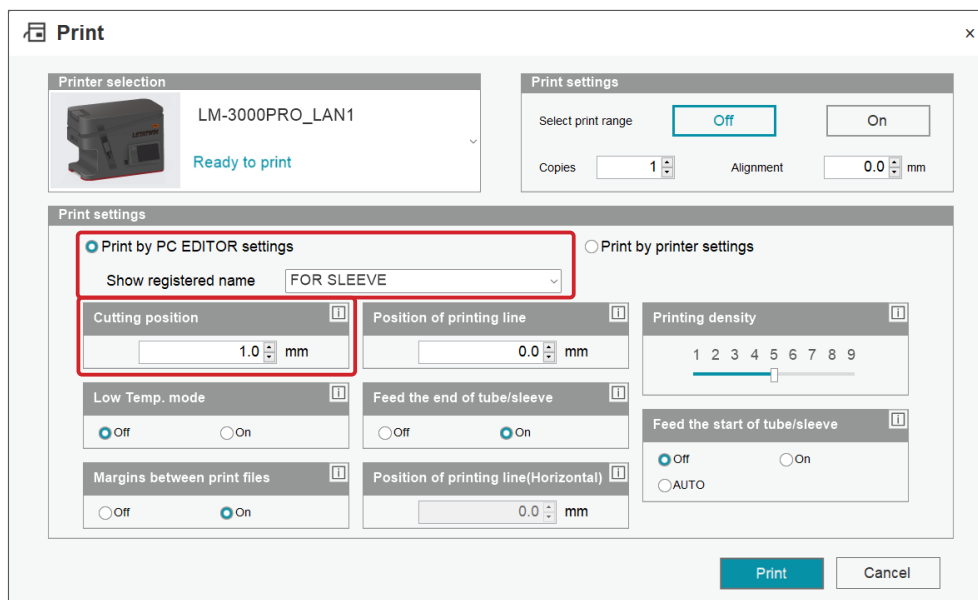

- Up to twenty print parameter settings can be registered for each model.

# 8-10 SAVING AND SENDING FILES

## Differences between saving and sending

Saving	The document being edited is saved to the <u>computer</u> or a <u>USB memory device inserted into the computer</u> under the specified name.
Sending	The document being edited is saved to <u>a USB memory device inserted into the main LM-3000PRO unit</u> . To send, a computer must be connected to the main unit.

## Saved file formats

File format	Extension	Applicable to:
LMP	.LMP	LM-3000PRO
LMF	.LMF	LM-550A3/550A2/550A
CSV	.CSV	All models

## CAUTION

When saving files in CSV format, the selected model and print material data are not saved.  
When saving files in CSV format, the only setting items that are saved are “Repeat” and “Pitch length.”  
To load and apply “Repeat” and “Pitch length” data saved in CSV file format, use “File” - “Import file.”

### → 9-3 IMPORTING CSV FILES

## Preparation for Saving Data to a USB Memory Stick

Create a folder named "LM-3000PRO" in the root directory of the USB memory stick. Inside this folder, create a subfolder with any name you like. The data that can be read by this device is limited to those saved in the subfolders within the second level.

## 8-10-1 SAVING FILES WITH A NEW NAME

### 1 Click “File” - “Save as.”

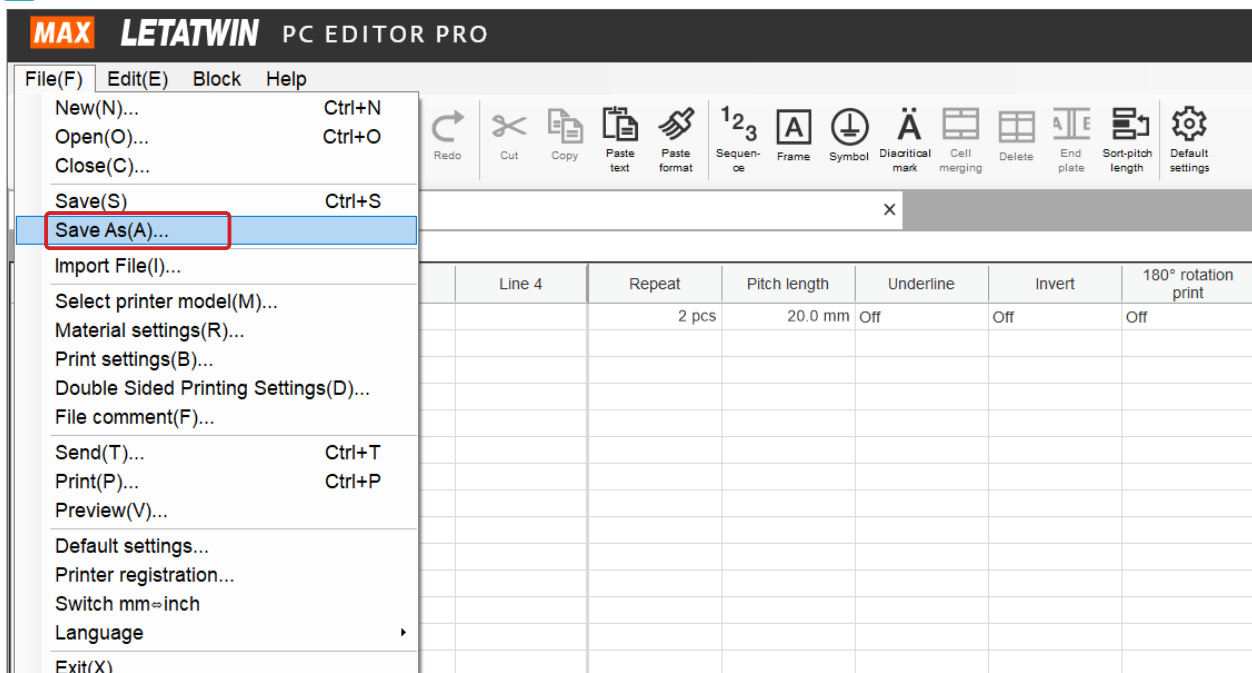

- 2** The “Save as” screen opens. Select a “File location,” enter a “File name,” then click the “Save” button to save.

The screenshot shows a 'Save as' dialog box with the following elements and callouts:

- 1**: File location: C:\Users\sis0980022\Downloads
- 2**: A table with columns: Name, Updated, Type.
- 3**: File name: (empty text box)
- 4**: File type: LETATWIN PC EDITOR PRO FILE FORMAT (\*.LMP)
- 5**: Encode type: UTF-8
- 6**: File comment: (text area with 'Edit' button and '0 / 100 characters' indicator)
- 7**: Setting model: LM-3000PRO

Buttons: Save, Cancel

①	Specify the location to save the file to.
②	Saved files are displayed in a list.
③	Enter a file name.
④	Select a file format to save the file in.
⑤	Select an encoding type (when saving files in CSV file format only).
⑥	Comments can be registered in saved files. Up to 100 characters can be entered. → 8-10-4 RECORDING COMMENTS IN FILES
⑦	Select the model with which the saved file is to be used. Use this setting when changing the model from the model that was set when the document was created.

### MEMO

- To save a file and overwrite the previous version, save with the file with the same name using the “Save” icon, or save using “File” - “Save.”
- The LM-3000PRO does not have a main unit memory.
- When printing with the LM-3000PRO using the main unit only, insert a USB memory device containing data saved in LMP file format for use.
- When printing from the main LM-3000PRO unit using a USB memory, only data in LMP file format can be used.
- The LM-550A3/550A2/550A cannot send data directly to a USB memory device inserted directly into the main unit.
- The LM-550A3/550A2/550A can send data to the main unit memory or directly to input documents on the main unit.
- When using a USB memory device to print with the LM-550W3/500W3/550W2/500W2/550W/500W, use a computer to save the LMF file in the root folder of the USB memory device.
- To change from a higher model to a lower model, select a model from “Save” → “Model setting,” then name the file and save the settings. After saving, use “Open” to open files.
- Model order:  
LM-3000PRO>LM-550A3>550A2>550A

## 8-10-2 SAVING FILES BY OVERWRITING

Clicking on the  icon saves the file and overwrites the previous version.

**MAX LETATWIN PC EDITOR PRO**

File(F) Edit(E) Block Help

New Open **Save** Send Print Preview Undo Redo Cut Copy Paste text Paste format Sequence Frame Symbol Diacritical mark Cell merging Delete End plate Sort-pitch length Default settings

LMPC1 X

1 - Line 1 X01

	Line 1	Line 2	Line 3	Line 4	Repeat	Pitch length	Underline	Invert	180° rotation print
1	X01				2 pcs	20.0 mm	Off	Off	Off
2	X02				2 pcs	20.0 mm	Off	Off	Off
3	X03				2 pcs	20.0 mm	Off	Off	Off
4									
5									
6									
7									
8									
9									
10									
11									
12									
13									
14									

## 8-10-3 SENDING FILES

The document being edited is saved to a USB memory device inserted into the main LM-3000PRO unit. To send, a computer must be connected to the main unit.

- 1 Click the  icon.

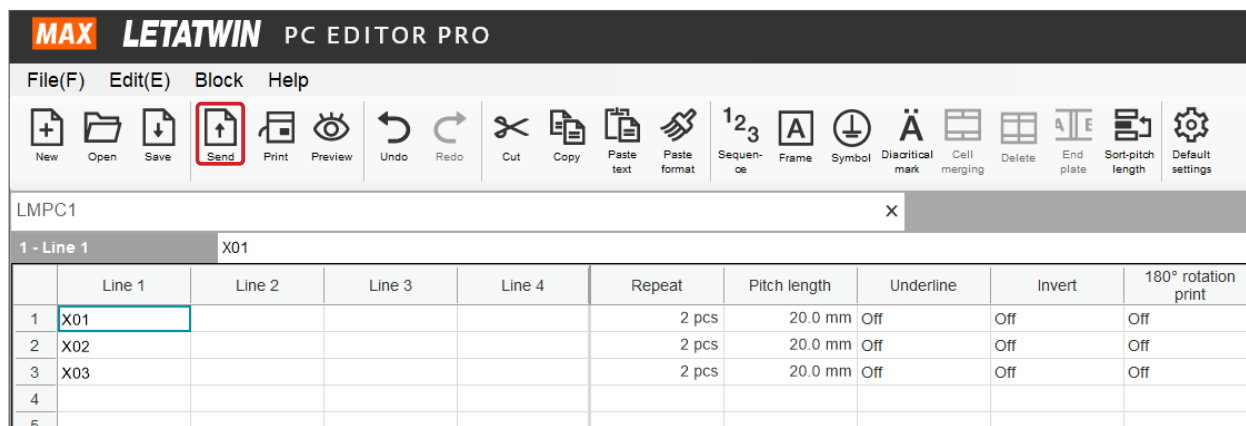

- 2 The “Send” screen opens. Select a “File location,” enter a “File name,” then click the “Send” button to send.

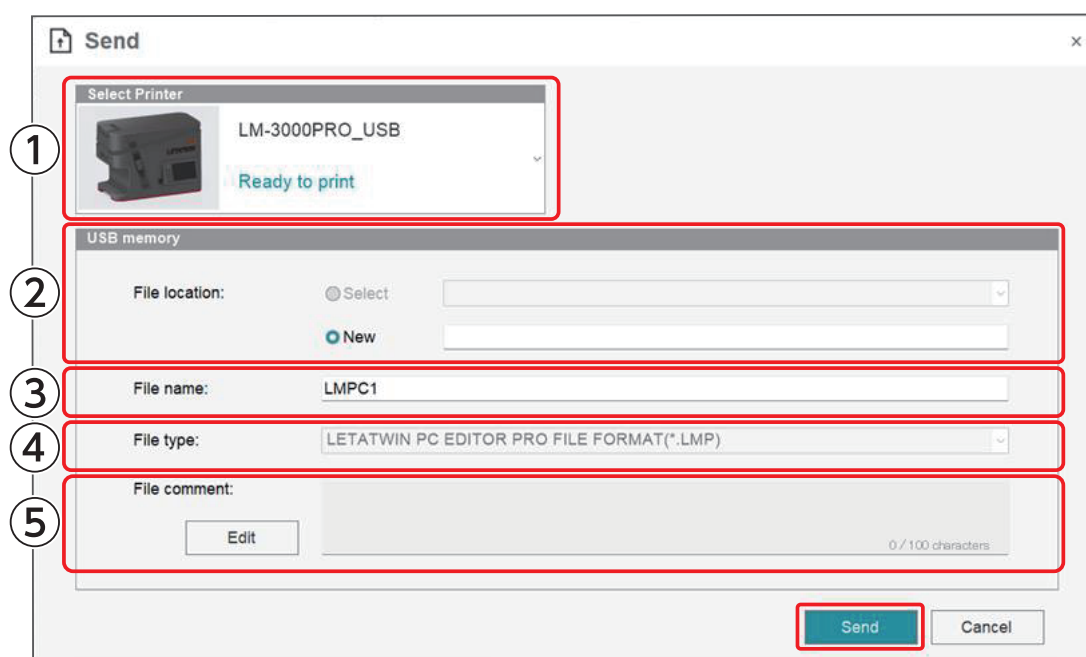

①	Select a machine to send the file to.	
②	Select a folder to save the file to.	Existing: Select a folder that has already been created. New: Create a new folder.
③	Enter a file name.	
④	file format.	
⑤	Comments can be registered in saved files. Up to 100 characters can be entered.	

➔ 8-10-4 RECORDING COMMENTS IN FILES

## 8-10-4 RECORDING COMMENTS IN FILES

File comments can be entered on the “Save as” screen, the “Send” screen and the main editing screen.

→ 8-10-3 SENDING FILES

→ 8-10-4 RECORDING COMMENTS IN FILES

**1** File comments are entered on the main editing screen.

Click “File” - “File comment” or click the  button.

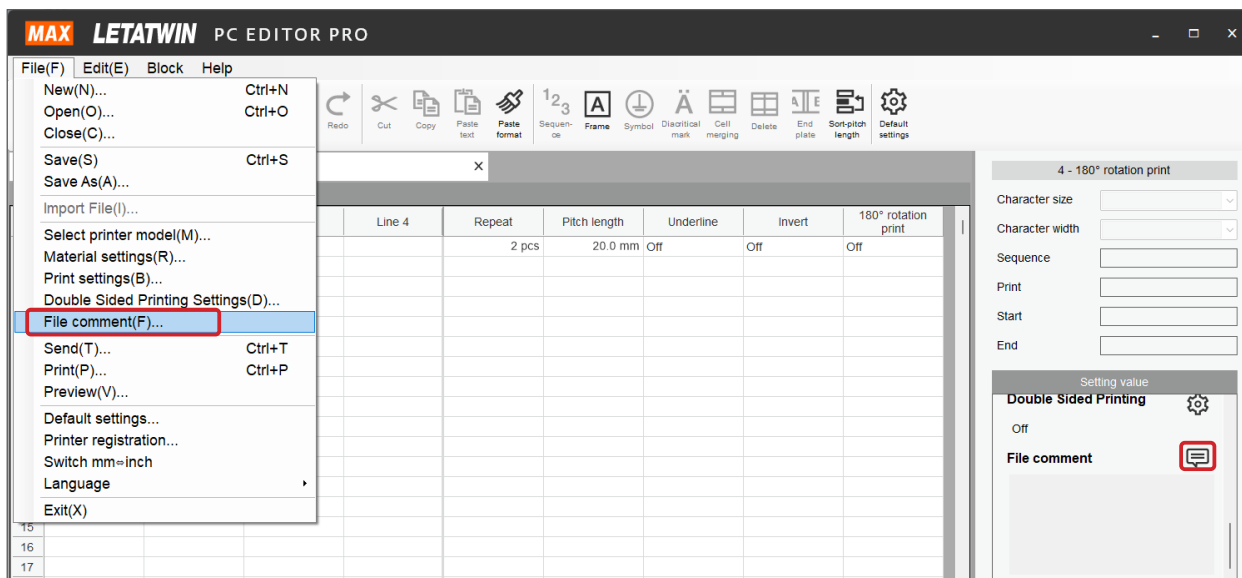

**2** Enter a file comment, then click the “OK” button.

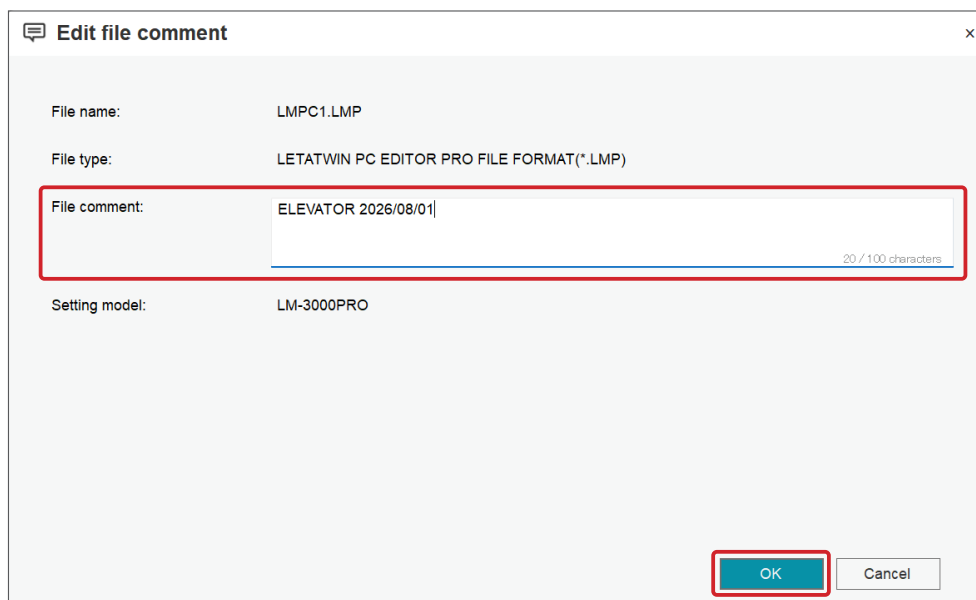

**3** The file comment is now registered.

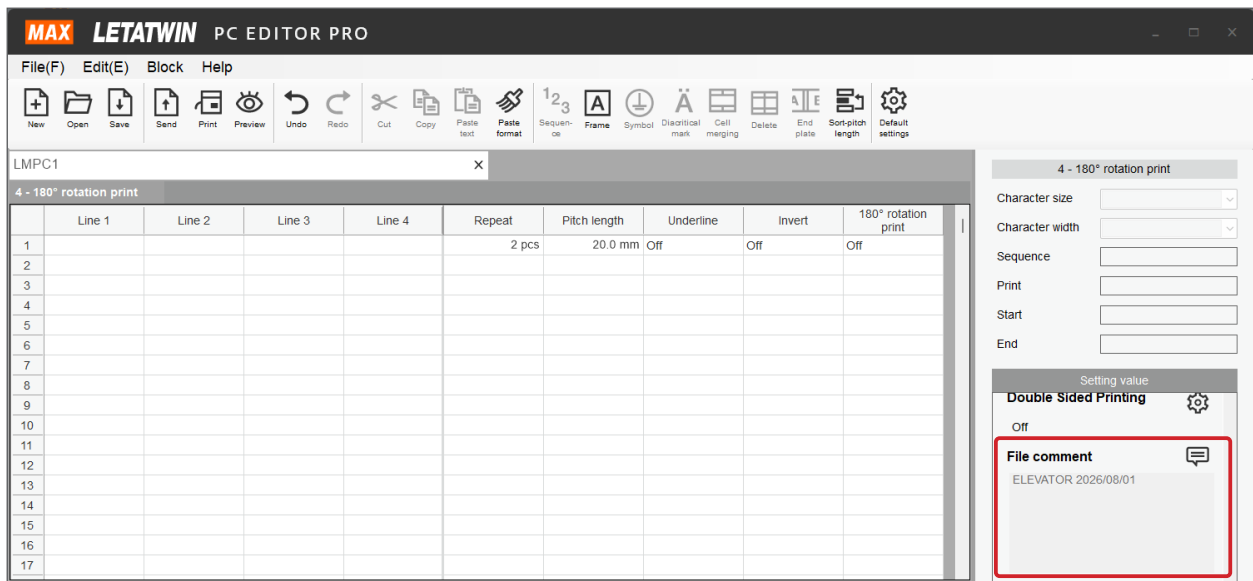

**4** File comments registered to a saved document can be checked when the saved document is recalled.

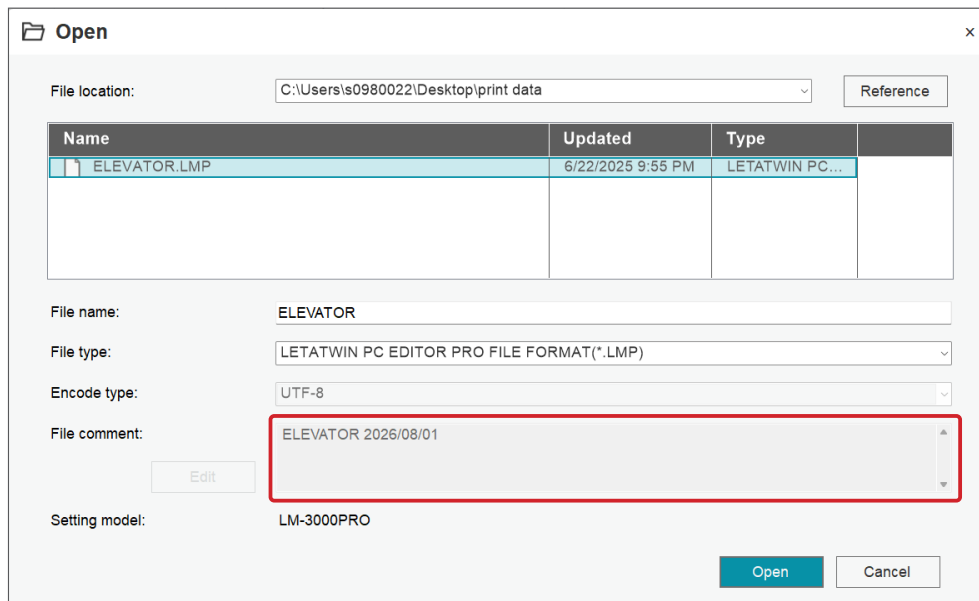

**MEMO**

- File comment text cannot include line breaks.
- A maximum of 100 characters can be entered for file comments.
- File comments in documents saved to a USB memory device can be checked on the main unit.

# 8-11 DOUBLE-SIDED PRINTING

Double-sided printing can only be performed on grip sleeves.

The double-sided printing function is a function that prints the same content that was printed on the front side on the rear side, rotated 180°.

Double-sided printing cannot print on both sides in a single pass. After printing on the front, remove the grip sleeve from the main printer unit, load it with the rear side facing up, then perform printing.

## Illustration of double-sided printing



- 1 Click “File” - “Double-sided printing settings.”

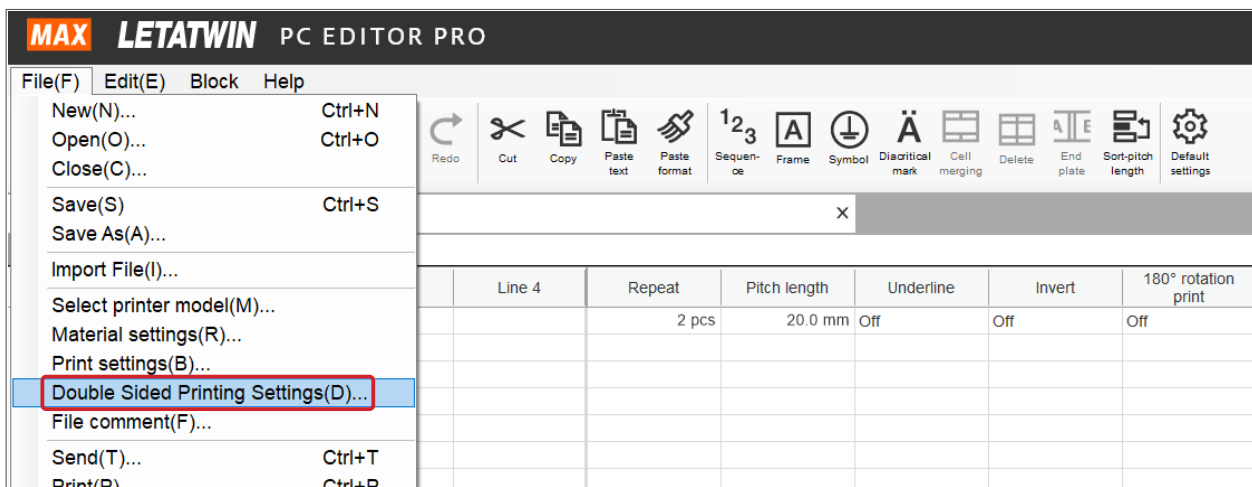

- 2 On the Guidance screen, select “ON,” then press the “OK” button.

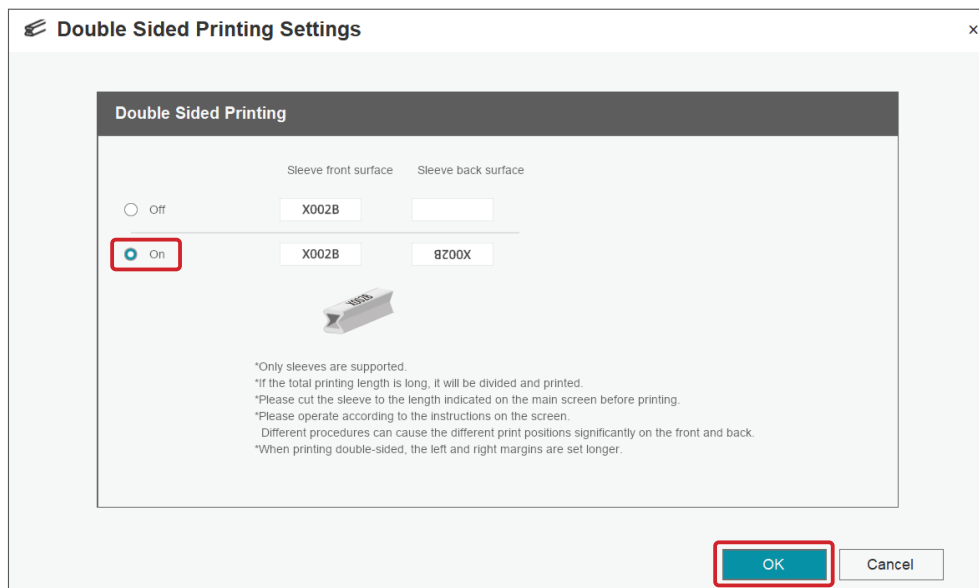

Double-sided printing setup is now complete.

Print from the LETATWIN PC EDITOR PRO or the main printer unit.

→ 6-2 PRINTING → 7-1-8 PRINTING

Next, set the grip sleeve in place as indicated by the printer and perform printing.

- The LCD screen on the main unit displays a QR code linking to the MAX website. An instructional video demonstrating relevant procedures can be viewed on the website. After watching the video, press the “OK” button.

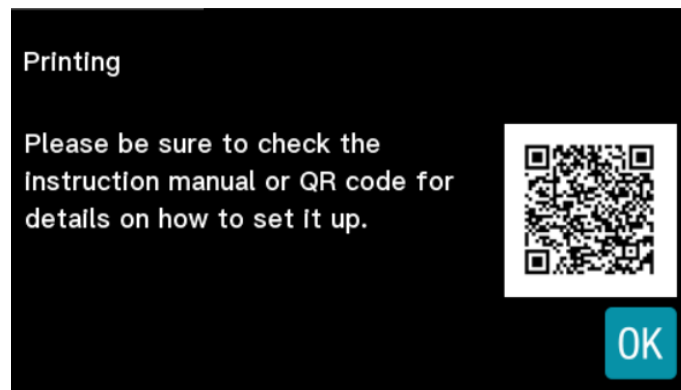

- Add markings on both the front and rear surfaces, 10cm from the end of the grip sleeve.

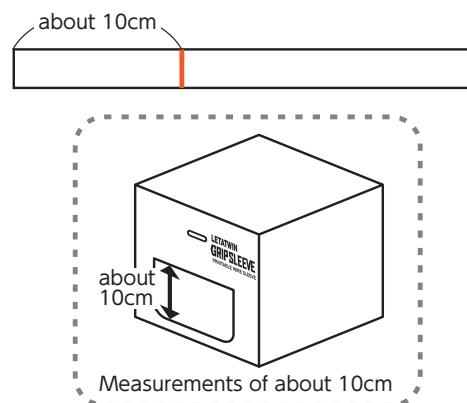
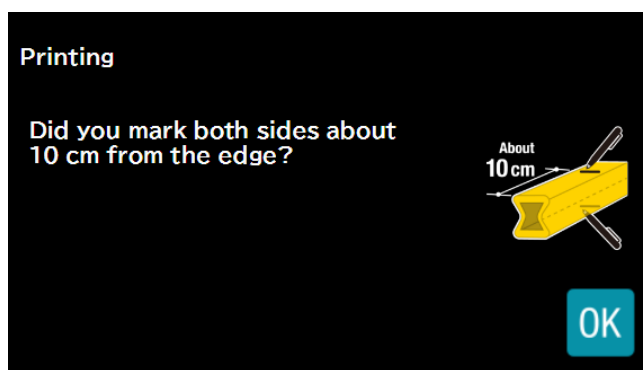

- Cut the grip sleeve to the specified length, then set it in the main unit. Do not press the “Restart” button yet.

\*Note that this differs from the regular procedure. Ensure that you read the following explanation before printing.

When the printing length exceeds 88cm, print in sections.

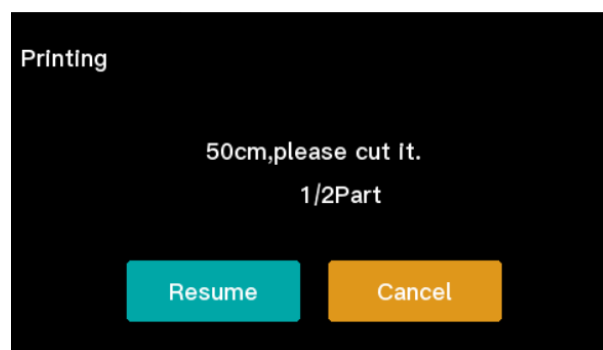

- 6** With the outside of the grip sleeve bobbin winder facing up, place the marking at the front end and set the cut grip sleeve in the main unit. Set the marking position with reference to the image below.

→ 4-4 LOADING GRIP SLEEVES

Grip sleeve curvature

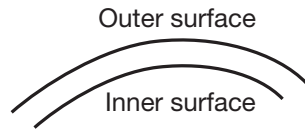

Grip sleeve setting position

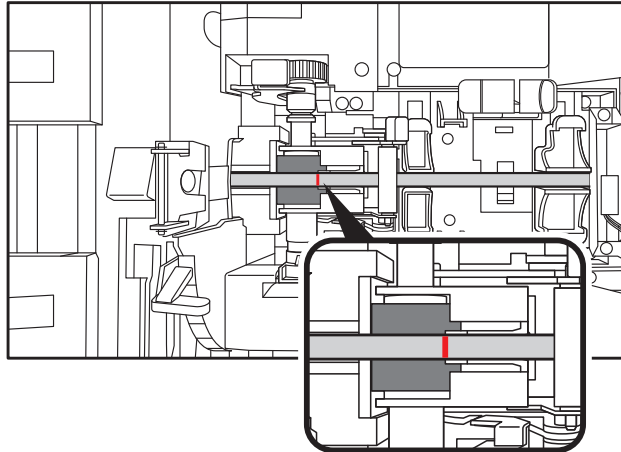

- 7** Close the door cover and press the “Restart” button.

\*Half cutting is not performed when printing on the front. Half cutting is performed when printing on the rear.

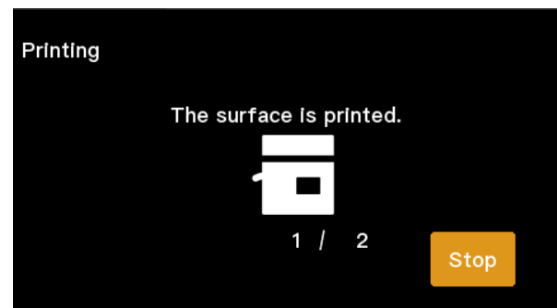
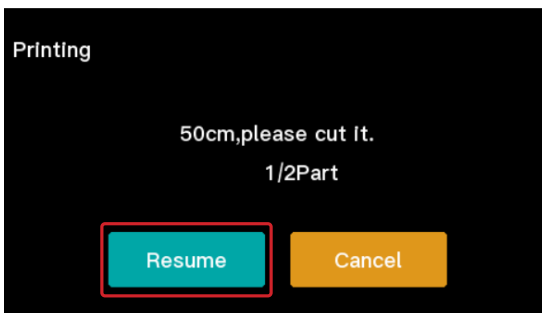

- 8** Open the door cover, turn the grip sleeve over and set it in position. The grip sleeve setting position is the same as when printing on the front.

\*Half cutting is performed when printing on the rear.

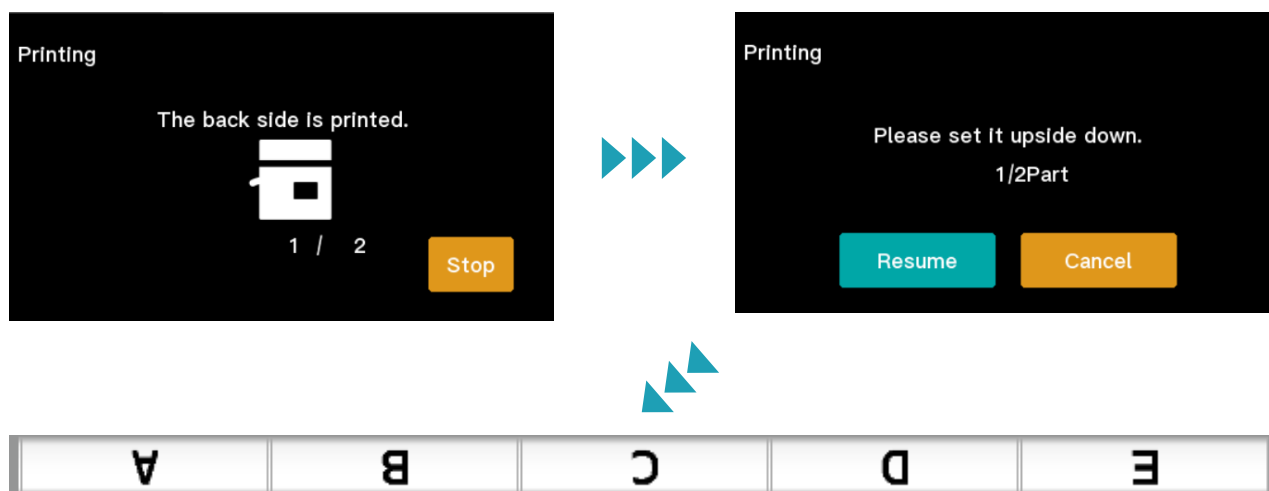

- 9** When printing in sections, repeat steps 4 to 8 to perform printing.

#### MEMO

- Always cut the grip sleeve to the length specified on the main unit screen before printing.
- The text printed on the front and rear sides must be the same.
- Operate in accordance with the guidance on the main unit screen. Failure to follow the correct procedure can cause the printing position to differ significantly between the front and rear.
- When double-sided printing is "ON," the left and right margin settings become longer.
- When the total print length exceeds 50cm, perform printing in sections. Operate in accordance with the guidance on the main unit screen.
- When printing from the main unit, double-sided printing cannot be switched on and off during use. Save double-sided printed settings onto a USB memory device before use.

# Chapter 9

## USING LETATWIN PC EDITOR PRO DATA

---

9-1 USING LETATWIN PC EDITOR PRO DATA.....	190
9-2 IMPORTING DATA CREATED USING SPREADSHEET SOFTWARE INTO LETATWIN PC EDITOR PRO.....	191
9-3 IMPORTING CSV FILES.....	192
9-3-1 IMPORTING PRINTING CONTENT ONLY.....	193
9-3-2 COPYING AND PASTING FROM CSV FILES.....	194
9-3-3 IMPORTING PRINTING CONTENT AND REPETITION AND PITCH LENGTH DATA.....	195
9-3-4 IMPORTING BY DRAGGING CSV FILES ONTO THE LETATWIN PC EDITOR PRO ICON.....	197

# 9-1 USING LETATWIN PC EDITOR PRO DATA

Data created using LETATWIN PC EDITOR PRO can be used in the following three ways.

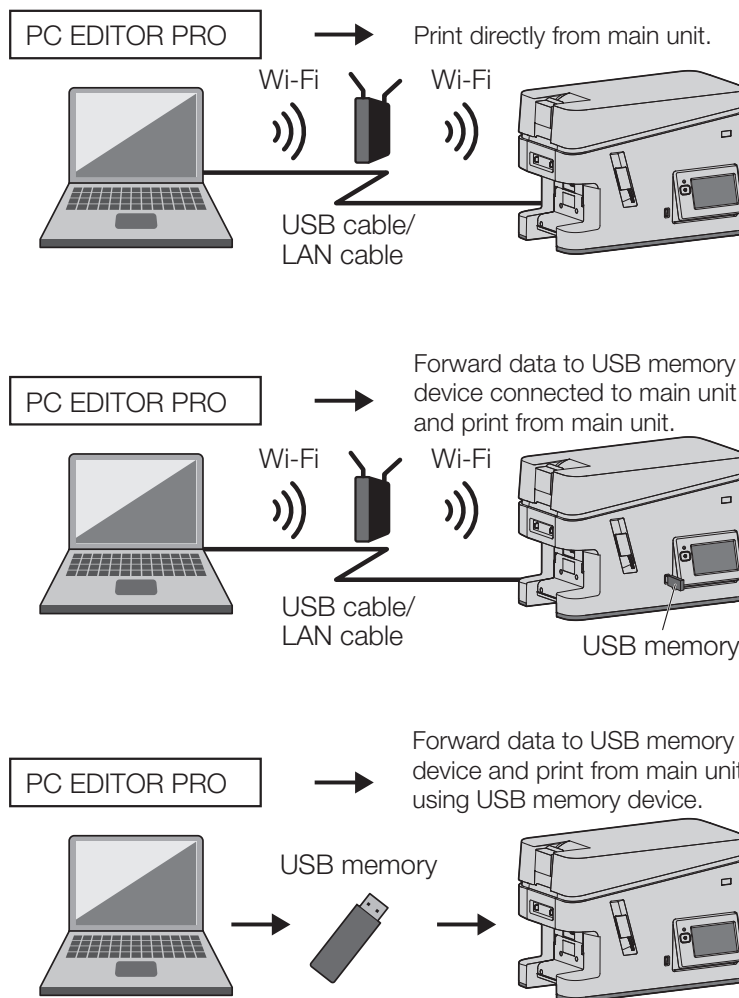

In addition to LM-3000PRO, LETATWIN PC EDITOR PRO also supports the following models.

	Printing directly from a computer	PC ↓ Forwarding data to a USB memory device	PC ↓ Forwarding data to the main unit memory	PC ↓ Forwarding data to a USB memory device connected to the main unit
LM-3000PRO	○	○	× (no main unit memory)	○
LM-550A3/550A2/550A	○	○	○	×

The data format varies depending on the model.

	Data format
LM-3000PRO	LETATWIN PC EDITOR PRO file format (*.LMP)
LM-550A3/550A2/550A	LETATWIN PC EDITOR PRO file format (*.LMF)

## MEMO

- USB memory devices with security functions cannot be used.
- Files saved directly to the USB memory device root cannot be read from the main unit. Always create a folder, then save files in that folder.
- When using the LM-3000PRO, folder and file names should not exceed 50 characters, regardless of whether single byte or double byte characters are used. Trailing characters that the main unit cannot display are cut off.
- When using LM-5xx series units, names should not exceed 8 single byte alphanumeric characters.
- Removing a USB memory device without performing the specified actions first can cause data to become corrupted.

# 9-2 IMPORTING DATA CREATED USING SPREADSHEET SOFTWARE INTO LETATWIN PC EDITOR PRO

PC EDITOR PRO can read CSV files created using Excel or another type of spreadsheet software.

When entering text using spreadsheet software, adhere to the rules below.

CSV File	Column A	Column B	Column C	Column D	Column E	Column F	Column G	Column H and beyond
Printing block	First line	Second line	Third line	Fourth line	Repeat	Pitch length	mm/inch Select	Disabled

\*Read using "Import file" when importing repeat and pitch length values.

Text entered in column A of the CSV file becomes the first row of the printing block and text entered in column B becomes the second row of the printing block.



First line	Second line	Third line	Fourth line	Repeat	Pitch length	mm/inch Select
A	B	C	D	E	F	G
COM				1	20	mm
R	X01			1	20	
S	X02			1	20	
T	X03			1	20	
V				1	20	
W				1	20	
COM	X01			1	20	
COM	X02			1	20	



- If column G is empty, the length unit is read as "mm."
- When specifying millimeters or inches, only enter a unit in the first line of column G.

# 9-3 IMPORTING CSV FILES

CSV files created using Excel or other spreadsheet software can be imported using the four methods shown below.

Import method	Importable CSV data range
Importing using "Open"	Applies to CSV data from column A to column D only. The specified values for "Repeat" in column E, "Pitch length" in column F and "mm/inch" in column G are not applied.
Copying and pasting from CSV files	Applies to CSV data from column A to column D only. The specified values for "Repeat" in column E, "Pitch length" in column F and "mm/inch" in column G are not applied.
Importing using "Import file"	CSV data from column A to column G can be imported. The specified "Repeat," "Pitch length" and "mm/inch" values are also applied.
Dropping CSV file onto icon	Applies to CSV data from column A to column D only. The specified values for "Repeat" in column E, "Pitch length" in column F and "mm/inch" in column G are not applied.

## Example input

	A	B	C	D	E	F	G
1	COM				2	25	
2	R	X01			2	25	
3	S	X02			2	25	
4	T	X03			2	25	
5	V				4	25	
6	W				4	25	
7	COM	X01			2	25	
8	COM	X02			2	25	

\*Due to the risk of character corruption, when saving or loading CSV files, specify the applicable encoding for each model, as shown below.

Model name	Encoding type when selecting CSV files
LM-3000PRO	UTF-8
LM-550A3	Shift-JIS
LM-550A2	
LM-550A	

## 9-3-1 IMPORTING PRINTING CONTENT ONLY

- 1 Click the  icon.

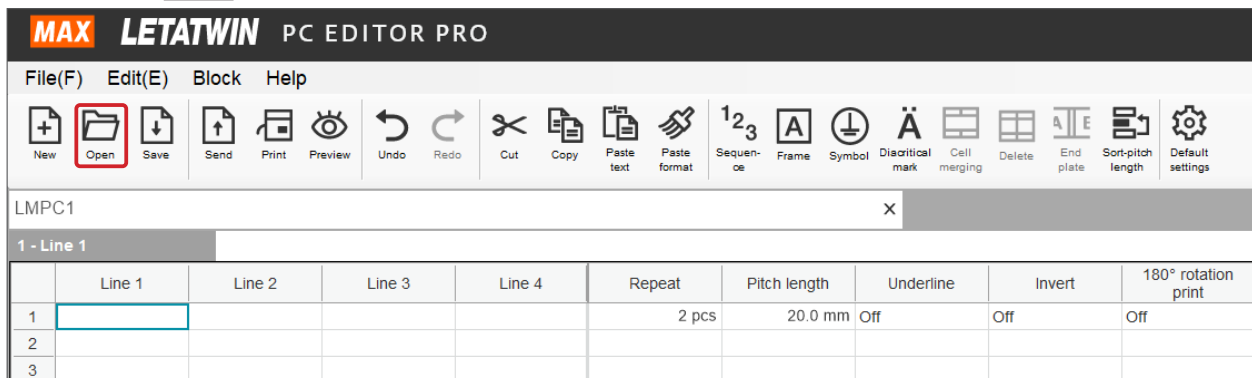

The screenshot shows the LETATWIN PC EDITOR PRO interface. The 'File(F)' menu is open, and the 'Open' button is highlighted with a red box. Below the menu, the main editing screen displays a table with columns: Line 1, Line 2, Line 3, Line 4, Repeat, Pitch length, Underline, Invert, and 180° rotation print. The table contains one row of data for 'Line 1'.

	Line 1	Line 2	Line 3	Line 4	Repeat	Pitch length	Underline	Invert	180° rotation print
1					2 pcs	20.0 mm	Off	Off	Off
2									
3									

- 2 Under "File type:," select "CSV file format (\*.CSV)", then specify the target file using the "Reference" button and click "Open."

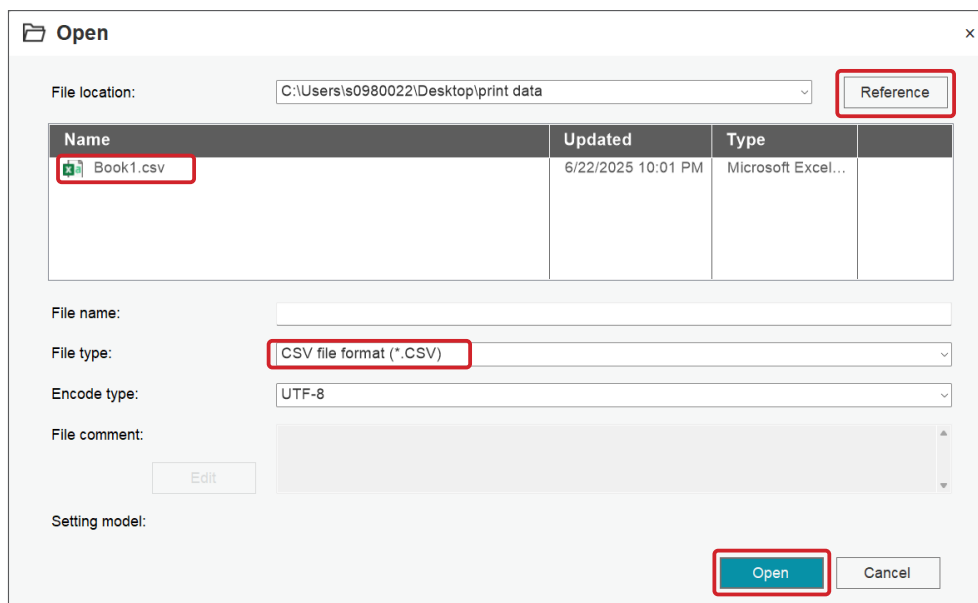

The screenshot shows the 'Open' dialog box. The 'File location' field is set to 'C:\Users\s0980022\Desktop\print data'. The 'Reference' button is highlighted with a red box. The file list shows 'Book1.csv' selected. The 'File type' dropdown is set to 'CSV file format (\*.CSV)'. The 'Open' button is highlighted with a red box.

Name	Updated	Type
Book1.csv	6/22/2025 10:01 PM	Microsoft Excel...

- 3 Data is loaded in the main editing screen.

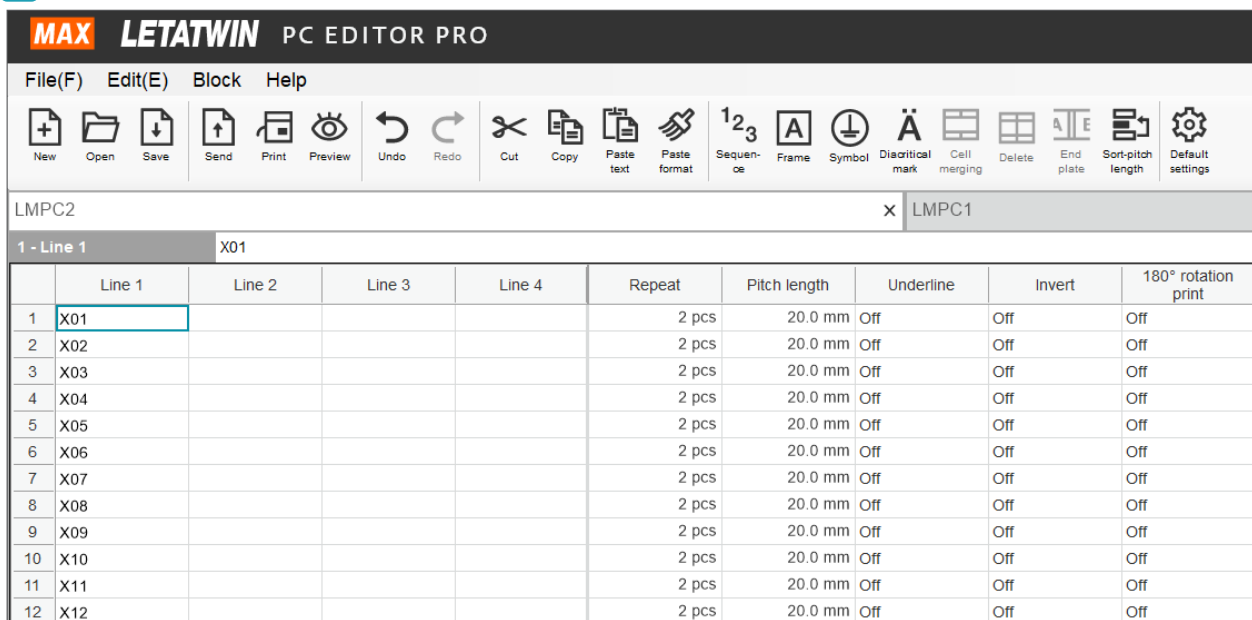

The screenshot shows the LETATWIN PC EDITOR PRO interface with the data loaded into the main editing screen. The 'File(F)' menu is open, and the 'Open' button is highlighted. The main editing screen displays a table with columns: Line 1, Line 2, Line 3, Line 4, Repeat, Pitch length, Underline, Invert, and 180° rotation print. The table contains 12 rows of data for 'Line 1'.

	Line 1	Line 2	Line 3	Line 4	Repeat	Pitch length	Underline	Invert	180° rotation print
1	X01				2 pcs	20.0 mm	Off	Off	Off
2	X02				2 pcs	20.0 mm	Off	Off	Off
3	X03				2 pcs	20.0 mm	Off	Off	Off
4	X04				2 pcs	20.0 mm	Off	Off	Off
5	X05				2 pcs	20.0 mm	Off	Off	Off
6	X06				2 pcs	20.0 mm	Off	Off	Off
7	X07				2 pcs	20.0 mm	Off	Off	Off
8	X08				2 pcs	20.0 mm	Off	Off	Off
9	X09				2 pcs	20.0 mm	Off	Off	Off
10	X10				2 pcs	20.0 mm	Off	Off	Off
11	X11				2 pcs	20.0 mm	Off	Off	Off
12	X12				2 pcs	20.0 mm	Off	Off	Off

## 9-3-2 COPYING AND PASTING FROM CSV FILES

**1** Copy a CSV file.

	A	B	C	D	E	F	G
1	COM				2	25	
2	R	X01			2	25	
3	S	X02			2	25	
4	T	X03			2	25	
5	V				4	25	
6	W				4	25	
7	COM	X01			2	25	
8	COM	X02			2	25	
9							
10							

**2** Select a paste destination, then click  icon.”

**MAX LETATWIN** PC EDITOR PRO

File(F) Edit(E) Block Help

New Open Save Send Print Preview Undo Redo Cut Copy **Paste text** Paste format Sequence Frame Symbol Diacritical mark Cell merging Delete End plate Sort-pitch length Default settings

LMPC1 x

1 - Line 1

	Line 1	Line 2	Line 3	Line 4	Repeat	Pitch length	Underline	Invert	180° rotation print
1					2 pcs	20.0 mm	Off	Off	Off
2									
3									
4									
5									
6									
7									
8									
9									
10									
11									
12									
13									
14									



- Under “File type;” select “CSV file format (\*.CSV)”, then specify the target file using the “Reference” button and click “Insert.”

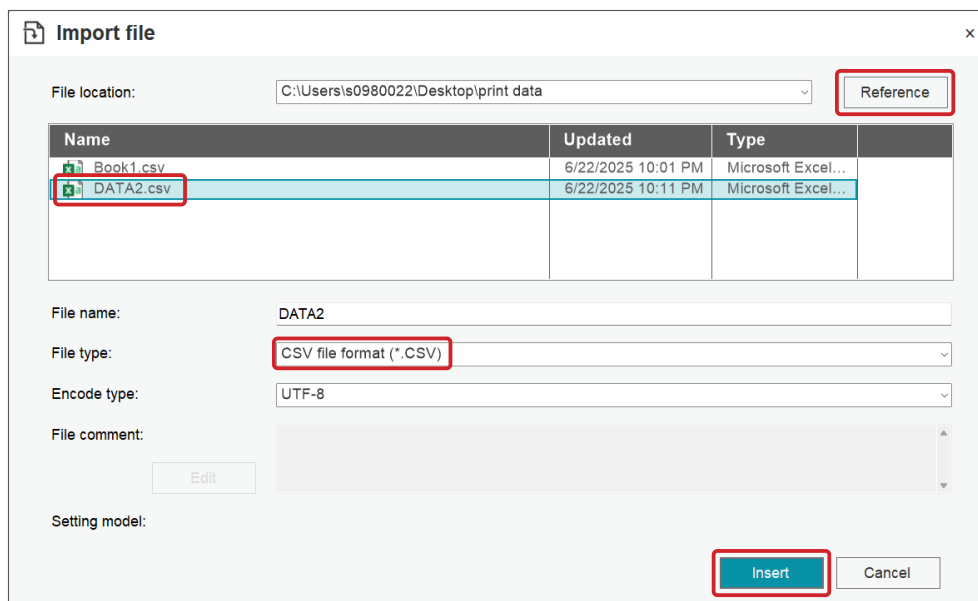

- The file is imported. The “Repeat” and “Pitch length” values are applied.

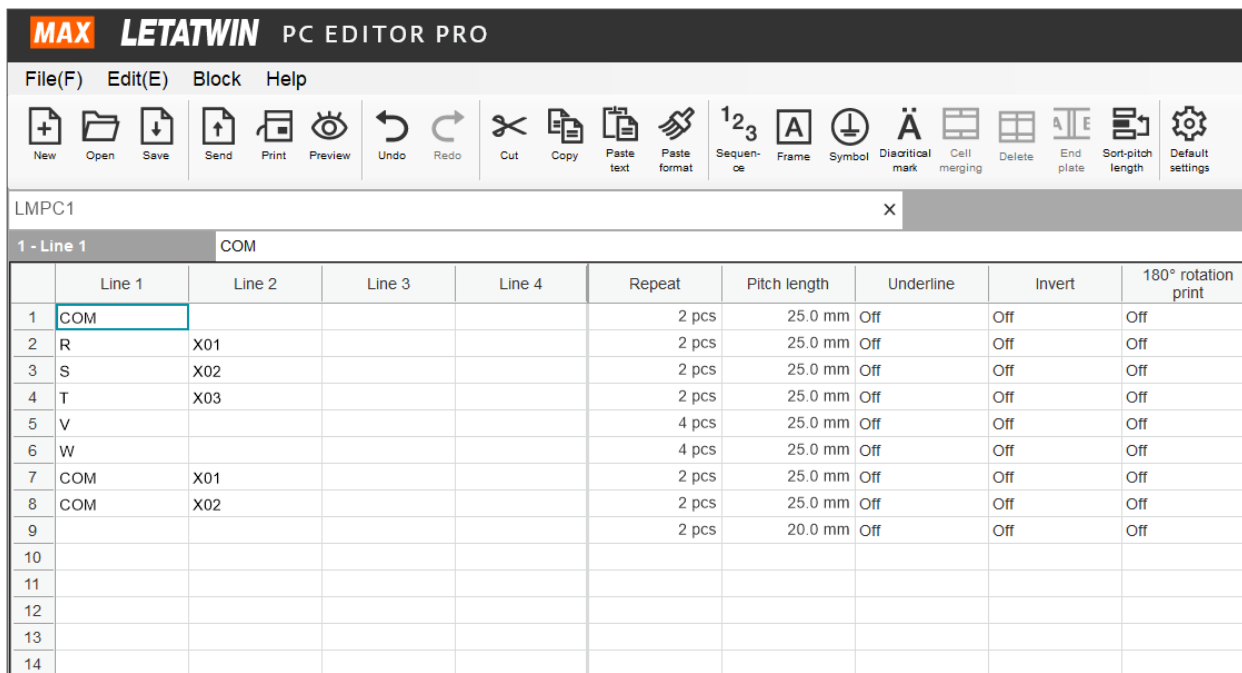

## 9-3-4 IMPORTING BY DRAGGING CSV FILES ONTO THE LETATWIN PC EDITOR PRO ICON

**1** CSV files can be imported by dragging them onto the LETATWIN PC EDITOR PRO icon.

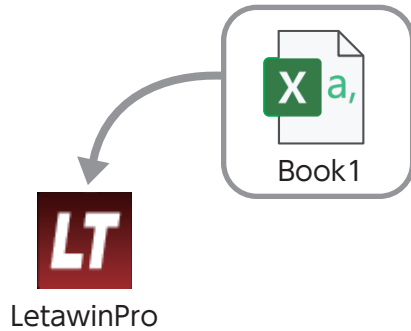

**2** The data is read. Next, select a model.

### MEMO

- Files cannot be pasted or imported if the pitch length has not been entered for two or more blocks.

# Chapter 10

## MAINTENANCE

---

10-1 PLATEN ROLLER CLEANING .....	199
10-2 THERMAL HEAD CLEANING.....	200
10-3 PRINT MATERIAL SENSOR CLEANING.....	201
10-4 CLEANING THE BLOCK MARKER SENSOR AND BLOCK MARKER ATTACHMENT .....	202
10-5 CLEANING MEDIA GUIDES B AND D (METHOD FOR REMOVING TAPE ADHESIVE) .....	203

# 10-1 PLATEN ROLLER CLEANING

To reduce disruption during use, perform regular maintenance on the main unit. Symptoms such as those described in this section indicate that the machine requires maintenance. In general, performing maintenance at least once per month is recommended. However, the optimal maintenance frequency varies depending on how often the machine is used and on the usage environment.

## Symptom

- The printed material block length is 2mm or more shorter than the set value.
- Printed text is shifted to the left.

## Cause

Dust or dirt stuck to the platen roller is affecting the feeding of print material.

## Required items

- A cloth dampened with water and wrung out thoroughly, or a soft cloth dampened with alcohol (do not use cloths prone to producing lint)

## Performing maintenance

- 1** Open the cover with the power off.
- 2** Remove the platen roller from the main unit.
- 3** <When removing dust and dirt>

Open the cover when the unit is off. Remove the roller from the main unit's turntable.

Using a damp, well-wrung cloth or a soft cloth dampened with alcohol, wipe away any dust or dirt adhering to the turntable roller.

<When removing the tape adhesive>

The tape adhesive is attached; press on the adhesive side of the tape to remove it.

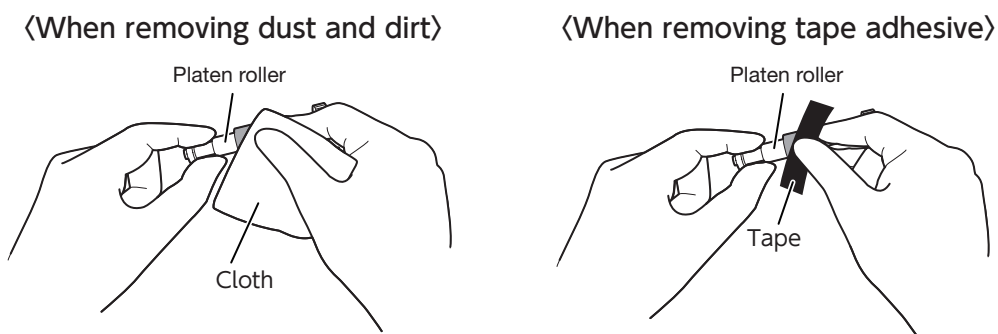

### NOTE

- Please print after the water and alcohol have dried.

# 10-2 THERMAL HEAD CLEANING

## Symptom

Printed characters have thin, horizontal white streaks.

## Causes

Dirt or dust has adhered to the thermal head and is affecting ink ribbon transfer.

## Required items:

- A cotton swab permeated with alcohol (ethanol is suitable)
- \*Wiping with a dry swab is also effective, however, using alcohol increases effectiveness.

## Performing maintenance

- 1** Turn OFF the main power switch on the rear on the main unit.
- 2** Open the door cover
- 3** Gently wipe the heating element in the center of the thermal head (see image) with a cotton swab permeated with alcohol.
- 4** If no improvement is observed, replace the thermal head.  
→ 5-2 REPLACING THE THERMAL HEAD

### NOTE

- Always turn the main power off at the rear of the main unit before cleaning.
- Do not touch the thermal head directly with fingers. Doing so can cause malfunction.
- If symptoms do not improve after cleaning the platen roller or thermal head, refer to the troubleshooting section.
- Wipe along the width of the thermal head.
- Please print after the alcohol have dried.

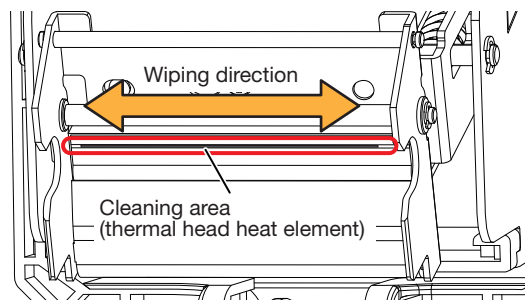

→ 11-1 TROUBLESHOOTING

# 10-3 PRINT MATERIAL SENSOR CLEANING

## Symptom

Printing continues even when there is no more print material.

## Causes

Dust or dirt is affecting the print material sensor, causing it to mistakenly detect print material even when none is present.

## Required items:

- A soft cloth  
(do not use cloths prone to producing lint)

## Performing maintenance

- 1** Turn OFF the main power switch on the rear on the main unit.
- 2** Open the door cover
- 3** Wipe the print material sensor with a soft, dry cloth.

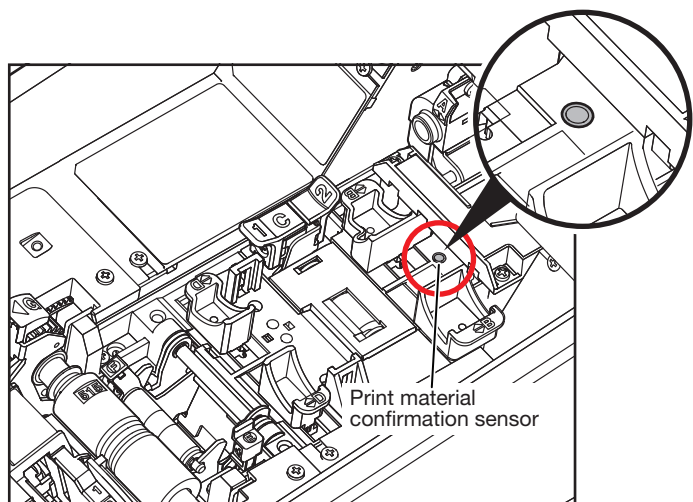

# 10-4 CLEANING THE BLOCK MARKER SENSOR AND BLOCK MARKER ATTACHMENT

The block marker sensor is only used during block marker printing.  
Clean the tip sensor and the block marker attachments at the same time.

## Symptom

- Blank unprinted blocks appear during continuous printing.
- An error message reading “Block marker not detected” is displayed.

## Causes

Dust or dirt has adhered to the sensor section, meaning the tip cannot be detected.

## Required items:

- A soft cloth or cotton swab  
(do not use cloths prone to producing lint)

## Performing maintenance

### (1) Block marker sensor cleaning

- 1** Turn OFF the main power switch (lock switch) on the rear on the main unit.
- 2** Open the door cover
- 3** Wipe the block marker sensor lens section with a soft, dry cloth.

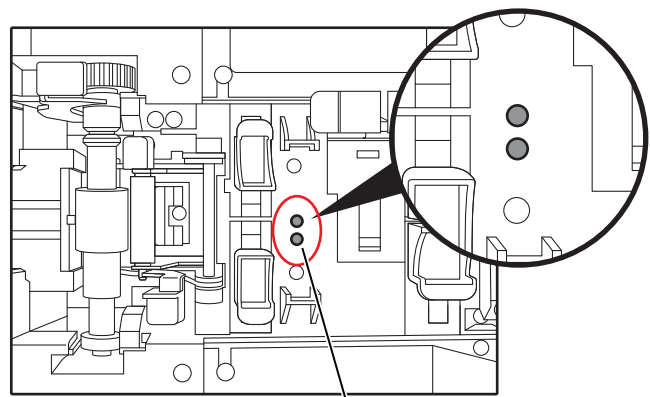

Block marker sensor

### (2) Block maker attachment cleaning

Wipe the lens section on the rear of the block marker attachment with a dry cloth or cotton swab.

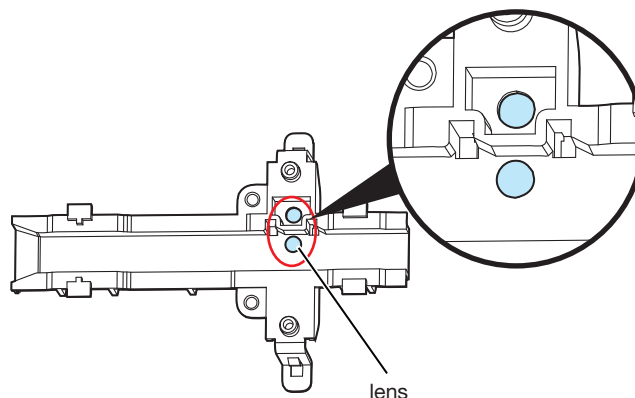

# 10-5 CLEANING MEDIA GUIDES B AND D (METHOD FOR REMOVING TAPE ADHESIVE)

## Symptom

- Tape is being wrapped around the platen roller.

## Causes

Is there adhesive on the platen roller or Media Guides B and D?

## Required items:

- Tape

## Performing maintenance

Cleaning Media Guides B and D.

- 1** Turn OFF the main power switch (lock switch) on the rear on the main unit.
- 2** Open the door cover.
- 3** Remove the adhesive from media guides B and D by pressing the adhesive surface of the tape against them.

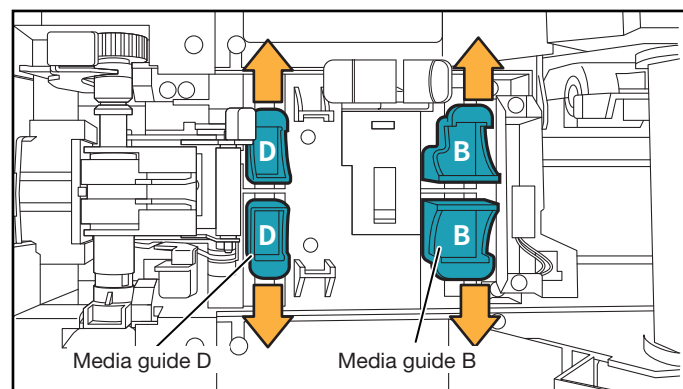
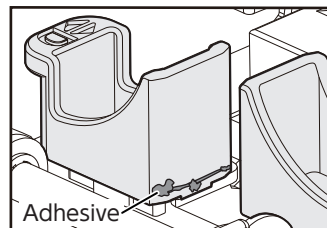

Tape adhesive from Media Guides B and D is being transferred and adhering to the platen roller. Please clean the platen roller and regularly clean Media Guides B and D.

→ 6-6 HELP

# Chapter 11

## TROUBLESHOOTING

---

11-1 TROUBLESHOOTING .....	205
----------------------------	-----

# 11-1 TROUBLESHOOTING

Issue	Checklist items	Countermeasures
The power does not turn on.	Is the power cord connected correctly?	Make sure the power cord is correctly connected to the main unit and to the electric outlet.
	Are the main power at the rear of the main unit and the secondary power at the front of the main unit turned on?	Turn ON the main power switch on the rear on the main unit, and turn ON the front sub power.
The screen display is dark or faint.	The screen is not properly adjusted.	Adjust the setting values as specified in the Owner's Manual. → 6-8-5 ADJUSTING SCREEN SETTINGS
The machine does not print.	Is the door cover closed?	Make sure the door cover is fully closed.
	Is the main unit's LCD screen displaying the home screen? (When printing from a computer)	Open the home screen on the main unit's LCD screen, then perform printing. → 6-1 HOME SCREEN
	Is "Operating printer" displayed on the LETATWIN PC EDITOR "Print" screen?	Open the home screen on the main unit's LCD screen, then perform printing. → 6-1 HOME SCREEN
Thin, unprinted streaks appear in the feeding direction.	Is the thermal head dirty?	Clean the thermal head. If cleaning does not resolve the issue, replace the thermal head. → 10-2 THERMAL HEAD CLEANING → 5-2 REPLACING THE THERMAL HEAD
The printed text appears faint or dark.	Is the printing density appropriate?	Print at the appropriate printing density. → 6-9-1 SETTING THE PRINTING DENSITY
	Is printing being performed at the appropriate print pressure?	Print at the appropriate printing pressure for the print material being used. → 4-3 ADJUSTING THE PRINTING PRESSURE
The printed text is uneven.	Is the platen roller dirty?	Clean the platen roller. → 10-1 PLATEN ROLLER CLEANING
	Is the platen roller worn?	If the platen roller is worn, replace it with a new one.
	Is printing being performed at the appropriate printing pressure for the type of print material?	Print at the appropriate printing pressure for the type of print material being used. → 4-3 ADJUSTING THE PRINTING PRESSURE
	Is the printing density appropriate?	Set to the appropriate printing density before printing. → 6-9-1 SETTING THE PRINTING DENSITY
The printing line position is misaligned vertically.	Is the print material set in position correctly? The vertical printing line position is not set correctly.	Set media guides B and D correctly to fit the width of the print material. Check the vertical printing line position adjustment value and set the printing line position accordingly. → 6-9-4 SETTING THE PRINTING LINE POSITION
The printing line position is misaligned horizontally.	Is the platen roller dirty?	Clean the platen roller. If the platen roller is worn, replace it with a new one. → 10-1 PLATEN ROLLER CLEANING
	The cutting position is not adjusted properly.	When performing printing with half cutting, adjust the horizontal printing line position according to the half cutting position. Check the cutting position settings, then properly adjust the cutting position before printing. → 8-8-6 SETTING THE CUTTING POSITION
	The horizontal printing line position is not adjusted correctly. (Block markers only)	When printing on block markers, adjust the printing line position with the "Position of printing line (Horizontal)" setting. → 8-8-11 ADJUSTING THE HORIZONTAL PRINTING LINE POSITION (BLOCK MARKERS ONLY)
The print material is not fed out.	Is the print material jammed near the print material outlet?	Open the jam removal cover and use tweezers to remove the print material. For thin tubes with a diameter of ø1.5 and ø2.0, which are particularly susceptible to curling, position so that the tube tip protrudes from the print material outlet before printing. → 4-6 CHANGING THE EXIT GUIDE

Issue	Checklist items	Countermeasures
Printing on sleeves cannot be performed correctly. · The printing position is misaligned.	Is a platen roller that corresponds to the sleeve size being used?	Use a platen roller that is appropriate for the size of the sleeves being used. → 4-4 LOADING GRIP SLEEVES
	Is there a gap of about 30cm between the main unit and the sleeve box?	Set in position with a gap of about 30cm between the main unit and the sleeve box. → 4-4 LOADING GRIP SLEEVES
	Are media guides B and D set to fit the sleeve width?	Set media guides B and D correctly to fit the sleeve width. → 4-4 LOADING GRIP SLEEVES
Printing on tubes and ID plates cannot be performed correctly. · The printing position is misaligned. · The printed text is broken.	Is the tube set in position correctly?	Set the tube in position correctly. → 4-5 LOADING TUBES AND ID PLATES
	Are media guides B and D set to fit the tube width?	Set media guides B and D correctly to fit the tube width. → 4-5 LOADING TUBES AND ID PLATES
	Is the tube tangled?	Untangle the tube and set it back in position.
	Is there oil or dirt on the tube?	Tubes with oil or dirt on them cannot be used. In particular, tubes with oil on them may not be usable even if wiped clean. Load a new, clean tube.
	Was the tube twisted during loading?	Straighten out any twists and set the tube back in position.
	Does the tube diameter setting match the diameter of the tubes that have been loaded?	If the tube diameter setting is incorrect, printing will not occur at the correct position. Make sure the setting matches the diameter of the installed tube.
	Has the room temperature fallen below 15°C?	In low temperature environments of 20°C or less, tubes may harden and printed text may become blurred or faint. If so, use the tube heater. → 4-5 LOADING TUBES AND ID PLATES → 6-5 SWITCHING THE HEATER ON AND OFF
	Are tube scraps clogging the interior of the machine?	Open the jam removal cover and use tweezers to remove any scraps. → 4-6 CHANGING THE EXIT GUIDE
	Is the correct exit guide being used?	Load the "WIDE" exit guide for shrinkable tubes between $\phi 12.0$ and $\phi 19.0$ , and the "NARROW" exit guide for other print material. → 4-6 CHANGING THE EXIT GUIDE
	An attachment is necessary for thin PVC tubes with a diameter of $\phi 1.5$ and $\phi 2.0$ or thick PVC tubes with a diameter of $\phi 8.0$ and $\phi 10$ . Is the mounted attachment appropriate for the tube diameter?	Mount the appropriate attachment for the tube diameter. → 4-5 LOADING TUBES AND ID PLATES
	Is the correct platen roller installed?	Install the correct platen roller. → 4-5 LOADING TUBES AND ID PLATES
	Are the correct ribbon flanges being used?	Only when printing on a $\phi 8.0$ and $\phi 10$ PVC tube, use the ribbon flanges for $\phi 8$ and $\phi 10$ (black color).
	Unable to print properly on the tape or marker strips.	Is the print material set in position correctly? Is the included reel stand being used?
Does the width setting of the tape match the installed tape?		Load tape with the same width as the one selected into the main unit.
Is it being used in an environment with a temperature of 15°C and lower or 35°C and higher?		Use in an environment with a temperature between 15 and 35°C.
The length measurement sensor (encoder) must be set in position to print on tape or marker strips. Is the length measurement sensor (encoder) set in position correctly?		Position the tape or marker strips correctly relative to the length measurement sensor (encoder). → 4-7 LOADING TAPE AND MARKER STRIPS
Are tube or tape scraps clogging the interior of the machine?		Open the exit guide and remove any scraps. → 4-6 CHANGING THE EXIT GUIDE

Issue	Checklist items	Countermeasures
Block marker printing is faint.	Is it set correctly?	→ 4-8 LOADING BLOCK MARKERS
	Is the printing density appropriate?	Please try lowering or increasing the print density. → 6-9-1 SETTING THE PRINTING DENSITY
		Please try reducing the printing speed. → 6-9-2 SETTING LOW TEMPERATURE MODE → 8-3-2 LOWERING THE PRINT SPEED
The block marker sticks to the ink ribbon.	Is the print density too high?	Please lower the print density. → 6-9-1 SETTING THE PRINTING DENSITY → 8-3-3 ADJUSTING THE PRINTING DENSITY
The print on the end of the block marker is misaligned.	The end of the block marker is difficult to detach from the reel.	Please remove the end of the block marker from the reel before printing.
The tape or marker strips are shorter than the specified setting.	Is the platen roller dirty?	Clean the platen roller. → 10-1 PLATEN ROLLER CLEANING
	Is the platen roller worn?	If the platen roller is worn, replace it with a new one.
	Are the tape or marker strips set correctly in the reel stand?	Make sure that the tape or marker strips are set correctly in the reel stand, and that they can be pulled out without resistance. Perform alignment before printing. → 8-8-4 PRINT ALIGNMENT
Half cutting cannot be performed. The half-cut function is not working.	Is the half cutter unit set in position correctly?	Correctly install the half cutter unit as instructed in the Owner's Manual. → 5-1 REPLACING THE HALF CUTTER UNIT
	Is the half-cut function set?	Please refer to the manual to set the half-cut function. → 8-1-12 HALF CUTTING/LINE AND DOT PRINTING BETWEEN PITCHES
Half cutting is performed, but the machine only leaves a mark and does not cut through.	Is the half-cutter depth adjustment too shallow?	Please refer to the manual to adjust the depth of the half-cutter. The cutting performance may vary depending on the temperature and tube characteristics. → 4-2 ADJUSTING THE HALF CUTTING DEPTH
	Is the blade old?	Replace with a new half cutter unit. → 5-1 REPLACING THE HALF CUTTER UNIT → 12-2 LIST OF PRINT MATERIAL AND OPTIONAL ITEMS
The machine cuts too deeply during half cutting.	Is the half cutter depth adjustment lever set properly?	Adjust the depth of the half cutter unit as instructed in the Owner's Manual. Cutting may be affected by the air temperature or the tube characteristics. → 4-2 ADJUSTING THE HALF CUTTING DEPTH
Unable to perform a half cut on the heat shrink tube.	Depending on the tube's wall thickness, a half cut may not be possible.	Please cut with scissors or similar tools.
	If the half cut is too deep, the consumable may be completely severed, causing damage to the blade edge.	Please replace with a new half cutter. → 5-1 REPLACING THE HALF CUTTER UNIT → 12-2 LIST OF PRINT MATERIAL AND OPTIONAL ITEMS
Manual full cutting cannot be performed (the machine cannot cut through).	Are print material scraps clogging the interior of the machine?	Open the jam removal cover and use tweezers to remove any print material scraps or other buildup that is present. → 3-2 PART NAMES
	Is print material clogging the interior of the machine?	
The print material is not detected.	Do media guides B and D precisely fit the width of the print material?	Make sure that media guides B and D precisely fit the width of the print material and that the material passes over the print material sensor.
	Is the print material sensor dirty?	Wipe the print material sensor with a dry cloth. → 10-3 PRINT MATERIAL SENSOR CLEANING
Tape is being wrapped around the platen roller.	Is there adhesive on the platen roller or Media Guides B and D?	Tape adhesive from Media Guides B and D is being transferred and adhering to the platen roller. Please clean the platen roller and regularly clean Media Guides B and D. → 10-5 CLEANING MEDIA GUIDES B AND D (METHOD FOR REMOVING TAPE ADHESIVE) → 6-6 HELP

# Chapter 12

## APPENDICES

---

12-1 LETATWIN PC EDITOR PRO DISPLAY CREATION DETAILS.....	209
12-2 LIST OF PRINT MATERIAL AND OPTIONAL ITEMS.....	212
12-3 LIST OF DEFAULT VALUES .....	215
12-4 PRODUCT SPECIFICATIONS .....	216
12-5 MAIN UNIT AND LETATWIN PC EDITOR PRO VERSION INFORMATION .....	219
12-5-1 MAIN UNIT VERSION INFORMATION.....	219
12-5-2 LETATWIN PC EDITOR PRO VERSION INFORMATION.....	219
12-5-3 HOW TO UPDATE THE MAIN UNIT .....	220
12-6 CONTACT INFORMATION.....	221

# 12-1 LETATWIN PC EDITOR PRO DISPLAY CREATION DETAILS

Tables cannot be created for patterns in which blocks without unit blocks are present. (For all blocks, create patterns so there is always an unmerged cell on one of the lines.)

- Red blocks: Error
- Yellow blocks: Unit block

Example

Example of print output

1	2	5
A		D E

	First line	Second line	Third line	Fourth line	Repeat	Pitch length	Underline	Invert	Rotation
1	1	A			1	5.0	No	No	No
2	2				1	5.0	No	No	No
3					1	5.0	No	No	No
4		D			1	5.0	No	No	No
5	5	E			1	5.0	No	No	No
6									
7									

In this example, with block number 2 and block number 3, the pattern cannot be accepted because there are no unmerged cells in the first or second line.

## Permitted patterns

Example of print output

1	2	3	4	5
A	B	C	D	E

	First line	Second line	Third line	Fourth line	Repeat	Pitch length	Underline	Invert	Rotation
1	1	A			1	5.0	No	No	No
2	2	B			1	5.0	No	No	No
3	3	C			1	5.0	No	No	No
4	4	D			1	5.0	No	No	No
5	5	E			1	5.0	No	No	No
6									
7									

Example of print output

1	3	4	5
A	B	C	

	First line	Second line	Third line	Fourth line	Repeat	Pitch length	Underline	Invert	Rotation
1	1	A			1	5.0	No	No	No
2	2	B			1	5.0	No	No	No
3	3	C			1	5.0	No	No	No
4	4	D			1	5.0	No	No	No
5	5	E			1	5.0	No	No	No
6									
7									

Example of print output

1	2	5
A	B	C D E

	First line	Second line	Third line	Fourth line	Repeat	Pitch length	Underline	Invert	Rotation
1	1	A			1	5.0	No	No	No
2	2	B			1	5.0	No	No	No
3		C			1	5.0	No	No	No
4		D			1	5.0	No	No	No
5	5	E			1	5.0	No	No	No
6									
7									

# Patterns that can be created by adjusting the merging point and pitch length

Example of print output

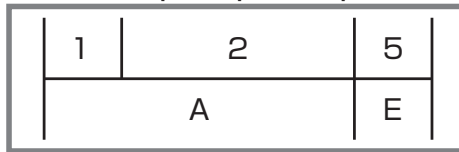

	First line	Second line	Third line	Fourth line	Repeat	Pitch length	Underline	Invert	Rotation
1	1	A			1	5.0	No	No	No
2	2				1	5.0	No	No	No
3					1	5.0	No	No	No
4					1	5.0	No	No	No
5	5	E			1	5.0	No	No	No
6									
7									

	First line	Second line	Third line	Fourth line	Repeat	Pitch length	Underline	Invert	Rotation
1	1	A			1	5.0	No	No	No
2	2				1	15.0	No	No	No
3	5	E			1	5.0	No	No	No
4					1				
5					1				
6									
7									

Reduce the number of cell merging points and adjust the pitch length.

Example of print output

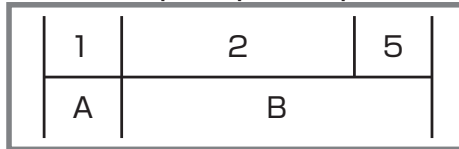

	First line	Second line	Third line	Fourth line	Repeat	Pitch length	Underline	Invert	Rotation
1	1	A			1	5.0	No	No	No
2	2	B			1	5.0	No	No	No
3					1	5.0	No	No	No
4					1	5.0	No	No	No
5	5				1	5.0	No	No	No
6									
7									

	First line	Second line	Third line	Fourth line	Repeat	Pitch length	Underline	Invert	Rotation
1	1	A			1	5.0	No	No	No
2	2	B			1	15.0	No	No	No
3	5				1	5.0	No	No	No
4									
5									
6									
7									

Reduce the number of cell merging points and adjust the pitch length.

Example of print output

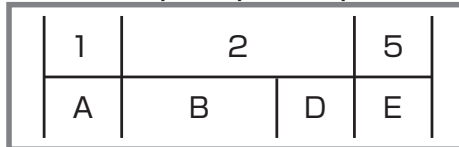

	First line	Second line	Third line	Fourth line	Repeat	Pitch length	Underline	Invert	Rotation
1	1	A			1	5.0	No	No	No
2	2	B			1	5.0	No	No	No
3					1	5.0	No	No	No
4		D			1	5.0	No	No	No
5	5	E			1	5.0	No	No	No
6									
7									

	First line	Second line	Third line	Fourth line	Repeat	Pitch length	Underline	Invert	Rotation
1	1	A			1	5.0	No	No	No
2	2	B			1	10.0	No	No	No
3		D			1	5.0	No	No	No
4	5	E			1	5.0	No	No	No
5									
6									
7									

Reduce the number of cell merging points and adjust the pitch length.

Example of print output

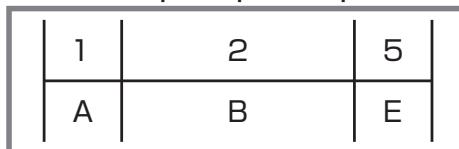

	First line	Second line	Third line	Fourth line	Repeat	Pitch length	Underline	Invert	Rotation
1	1	A			1	5.0	No	No	No
2	2	B			1	5.0	No	No	No
3					1	5.0	No	No	No
4					1	5.0	No	No	No
5	5	E			1	5.0	No	No	No
6									
7									

	First line	Second line	Third line	Fourth line	Repeat	Pitch length	Underline	Invert	Rotation
1	1	A			1	5.0	No	No	No
2	2	B			1	15.0	No	No	No
3	5	E			1	5.0	No	No	No
4									
5									
6									
7									

Reduce the number of cell merging points and adjust the pitch length.

## Patterns for which tables cannot be created

Tables cannot be created for the following patterns.

**Example of print output**

1	2	5
A		D E

	First line	Second line	Third line	Fourth line	Repeat	Pitch length	Underline	Invert	Rotation
1	1	A			1	5.0	No	No	No
2	2				1	5.0	No	No	No
3					1	5.0	No	No	No
4		D			1	5.0	No	No	No
5	5	E			1	5.0	No	No	No
6									
7									

**Example of print output**

1	2	5
A	C D	E



	First line	Second line	Third line	Fourth line	Repeat	Pitch length	Underline	Invert	Rotation
1	1	A			1	5.0	No	No	No
2	2				1	5.0	No	No	No
3		C			1	5.0	No	No	No
4		D			1	5.0	No	No	No
5	5	E			1	5.0	No	No	No
6									
7									



**Example of print output**

1	2	5
A	B C	D

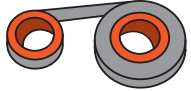
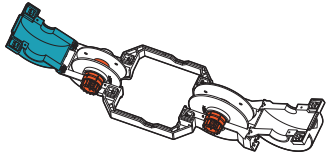
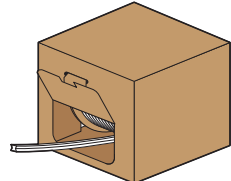
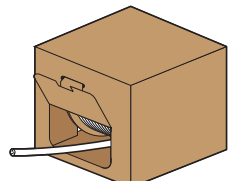
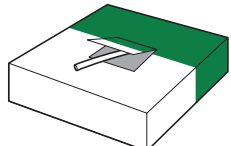
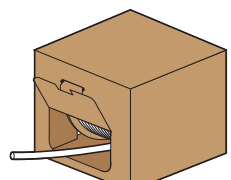
	First line	Second line	Third line	Fourth line	Repeat	Pitch length	Underline	Invert	Rotation
1	1	A			1	5.0	No	No	No
2	2	B			1	5.0	No	No	No
3		C			1	5.0	No	No	No
4		D			1	5.0	No	No	No
5	5				1	5.0	No	No	No
6									
7									

# 12-2 LIST OF PRINT MATERIAL AND OPTIONAL ITEMS

Ink ribbons				
Black: LM-IR3015B (For LM-3000PRO only, 200m roll, common to all consumables)				
White: LM-IR3015W (For LM-3000PRO only, 180m roll, for shrinkable tubes)				
Ink ribbon cassette				
LM-RC3015				
Grip sleeves (UL224 certified)				
Supported electrical wire outer diameters				
ø2.1 to ø3.4mm		LM-SL34W (white, 75m roll)		
ø3.0 to ø3.7mm		LM-SL37W (white, 75m roll)		
ø2.1 to ø3.4mm		LM-SL34Y (yellow, 75m roll)		
ø3.0 to ø3.7mm		LM-SL37Y (yellow, 75m roll)		
Grip tubes				
		Applicable electrical cables outer diameter		
Inner diameter: ø2.9mm	ø1.9mm to ø2.1mm	LM-TU29G (100m roll)		
Inner diameter: ø3.7mm	ø 2.5mm to ø2.7mm	LM-TU37G (100m roll)		
Inner diameter: ø4.6mm	ø 3.0mm to ø3.7mm	LM-TU46G (85m roll)		
Round tubes (UL224 certified)				
Inner diameter: ø3.2mm	LM-TU332N2 (100m roll)			
Inner diameter: ø3.6mm	LM-TU336N2 (100m roll)			
Inner diameter: ø4.2mm	LM-TU342N2 (80m roll)			
Inner diameter: ø5.2mm	LM-TU352N2 (80m roll)			
* UL224 certified tubes are designed to withstand voltages of up to 600V and heat up to 105°C, have a tube thickness of 0.431mm or more and offer VW-1 flame retardance. These tubes can be used as insulation tubing.				
Drum roll round tubes				
Inner diameter: ø2.5mm	LM-TU425L2 (250m roll)			
Inner diameter: ø2.7mm	LM-TU427L2 (250m roll)			
Inner diameter: ø3.2mm	LM-TU432L2 (250m roll)			
Inner diameter: ø3.4mm	LM-TU434L2 (250m roll)			
Inner diameter: ø3.6mm	LM-TU436L2 (250m roll)			
Inner diameter: ø4.2mm	LM-TU442L (200m roll)			
Inner diameter: ø5.2mm	LM-TU452L (135m roll)			
Inner diameter: ø6.4mm	LM-TU464L (100m roll)			
Inner diameter: ø8.0mm	LM-TU480L (70m roll)			
Tape				
		White (30m roll)		Yellow (30m roll)
5mm (W)	LM-TP3005W	LM-TP3005Y		
9mm (W)	LM-TP3009W	LM-TP3009Y		
12mm (W)	LM-TP3012W	LM-TP3012Y		

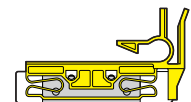
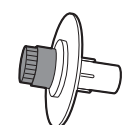
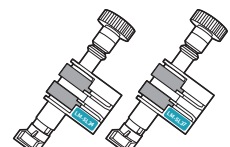
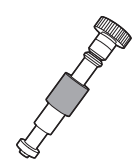
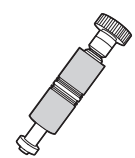
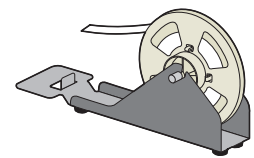
Marker strips			
8.5mm (W)	LM-KM485	(25m rolls, 5 rolls/box, 0.5mm thick)	
9.5mm (W)	LM-KM495	(25m rolls, 5 rolls/box, 0.5mm thick)	
10.0mm (W)	LM-KM410	(25m rolls, 5 rolls/box, 0.5mm thick)	
10.7mm (W)	LM-KM4107	(25m rolls, 1 rolls/box, 0.5mm thick)	
ID plates			
4.1mm (W)	LM-ID PLATE4110 (20m roll, 1.0mm thick)		
Half cutter unit			
LM-HC3000	(For LM-3000PRO only)		
LETATWIN PC EDITOR PRO			
Download LETATWIN PC EDITOR PRO from the MAX website.			
<a href="#">→ 3-8 DOWNLOADING AND INSTALLING LETATWIN PC EDITOR PRO</a>			
Dedicated ribbon flanges for ø8 and ø10 tubes *Handled as components.			
Ribbon flanges for ø8 and ø10 tubes			
Platen roller			
For grip sleeves (2 types)	LM-PR SL34		
	LM-PR SL37		
For tubes, tape and marker strips	LM-PR NORMAL		
For block markers (4 types)	LM-PR115	For A2009-113, 114, 115	
	LM-PR145	For A2009-145	
	LM-PR515	For A2009-515	
	LM-PR615	For A2009-615	
Reel stand (with tape flanges) *Handled as components.			
Reel stand (with flanges)			

**Attachments \*Handled as components.**

(1) Attachment for $\varnothing 1.5$ to $\varnothing 2.0$ tubes	
(2) Attachment for $\varnothing 8$ tube	
(3) Attachment for $\varnothing 10$ tube	
(4) Attachment for block markers (supports 113, 114, 115, 515, 615)	
(5) Attachment for block markers (supports 145)	
(6) Attachment for ID plates	

Block markers (list of supported WAGO products)	
WAGO product number	Name displayed on LM-3000PRO
2009-113	A2009-113
2009-114	A2009-114
2009-115	A2009-115
2009-145	A2009-145
2009-515	A2009-515
2009-615	A2009-615

# 12-3 LIST OF DEFAULT VALUES

## LETATWIN PC EDITOR PRO Initial setting values

	Item	LM-3000PRO		LM-550A3	LM-550A2	LM-550A
Basic settings	Pitch length initial value	Grip sleeves / tubes	20.0mm	20.0mm (tubes only)	20.0mm (tubes only)	20.0mm (tubes only)
		MAX ID plates	18.0mm	/	/	/
		Tape	10.0mm	10.0mm	10.0mm	10.0mm
		Marker strips	10.0mm	10.0mm	10.0mm	10.0mm
		End plate	1.5mm	/	/	/
	Repeat initial value	Grip sleeves / Tubes	2	2	2	2
		MAX ID plat	2	/	/	/
		Tape	1	1	1	1
		Marker strips	1	1	1	1
		Block markers	1	/	/	/
Character size	3.0mm		3.0mm	3.0mm	3.0mm	
Character width	100%		100%	100%	100%	
Print format	Table mode	OFF		/	/	/
	Pitch length	Select		Select	Select	Select
	Character size auto	Standard Auto		Standard Auto	Standard Auto	Standard Auto
	Pitch cutting	Half cutting		Half cutting	Half cutting	Half cutting
	Vertical/Horizontal	Horizontal		Horizontal	Horizontal	Horizontal
	Character space	Standard		Standard	Standard	Standard
	Line space	Standard		Standard	Standard	Standard
	Font choices	Clear font		Clear font	Clear font	Standard (set on main unit)
	6.9 MARK	OFF		OFF (set on main unit)	OFF (set on main unit)	OFF (set on main unit)
	Zero slash	OFF		OFF	OFF	OFF
	Frame	OFF		OFF	OFF	OFF
Sequence & Repeat	Prioritize sequence (11, 22, 33)		Prioritize repeat 11 22 33	Prioritize repeat 11 22 33	Prioritize repeat 11 22 33	
Text parameters Setting	Cutting position	0.0mm		0.0mm	0.0mm	0.0mm
	Printing line position	0.0mm		0.0mm	0.0mm	0.0mm
	Printing density	5		4	4	4
	Low temperature mode	OFF		OFF	OFF	OFF
	Pre-print feed	OFF		OFF	OFF	OFF
	Post-print feed	ON		/	/	/
	Margins between print files	ON		/	/	/
	Horizontal printing line position adjustment	0.0mm		/	/	/

### MEMO

- LETATWIN PC EDITOR PRO does not offer the "Print length mode" equipped on LM-5xx series machines.  
When using "Print length mode" with LM-5xx series products, perform creation using the previous software (LETATWIN PC EDITOR) or on the main LM-5xx unit.

# 12-4 PRODUCT SPECIFICATIONS

Model name	LM-3000PRO
Product type	Tube marker
Character input limit	5,000 characters (2,000 blocks)
Character type	Conforms with JIS Level 1 Kanji, Level 2 Kanji and other JIS standards (hiragana, katakana, alphanumeric characters, etc.)
Font	Standard, Bold, Clear, Square, Vietnamese
Character size (height)	1.3/2/3/4/6mm alphanumeric characters, 2.4mm also selectable for some symbols
Display	4.3-inch color LCD display
Printing method	Thermal transfer method (300dpi)
Printing speed	80mm/s (Number of tubes produced: 85/min With ø3.2 tubes, 20mm pitch, 7 characters)
Maximum print length (when printing one copy)	Grip sleeves: 100m, Tubes: 100m, Tape: 5m, Marker strips: 5m, Block markers: 1,000, ID plates: 20m
Supported consumables	Grip sleeves (LM-SL34: Finished electrical wire outer diameter of ø2.1 to ø3.4, LM-SL37: Finished electrical wire outer diameter of ø3.0 to ø3.7) Grip tubes (inner diameter: ø2.9 to ø4.6) PVC tubes (inner diameter: ø1.5 to ø10.0) Shrinkable tubes (inner diameter: ø2.0 to ø19.0) MAX tape (widths: 5/9/12mm) Marker strips (widths: 5.5 to 12.0mm) Block marker (WAGO products 2009-113, 2009-114, 2009-115, 2009-145, 2009-515, 2009-615) ID plates (width: 4.1mm)
Cutting method	Half cutting: Automatic, Full cutting: Manual
Main unit memory	None
External memory	USB memory (USB memory with security features cannot be used. Only those formatted with FAT12/16/32.)
Power supply	AC100-240V 50/60Hz
Power consumption	Maximum of 70W, 15W or less in standby mode, 10W or less in sleep mode
Interface	USB(A), USB(B), Wired LAN, Wireless LAN (IEEE802.11.b/g/n) (n is 2.4GHz only) (Station mode only), (Modulation: DSSS[11b], OFDM[11g/n])
Wireless LAN security	WPA-TKIP, 128-bit WPA2 CCMP (AES)
Tube heater	Built in
Operating environment	Temperature: 5 to 35°C, Humidity: 20% to 80%, No condensation
Dimensions	427 (W) × 256 (D) × 301 (H) mm
Weight	Approx. 11Kg (excluding accessories and power cord)
Included accessories	<ul style="list-style-type: none"> <li>· Power cord · Ink ribbon (LM-IR3015B) · Ink ribbon cassette · Reel stand</li> <li>· Quick reference manual · Safety guidance</li> <li>· Platen rollers (3 types) (for LM-SL34, LM-SL37, and NORMAL)</li> <li>· Attachments (6 types) (for A2009-145 (for block markers), A2009-113/114/115/515/615, ø1.5 to ø2.0 tubes, ø8.0 tubes, ø10.0 tubes, and ID plates)</li> <li>· Platen case, · software use license</li> </ul>
Supported OS	Windows11

## Operating environment

Common usage requirements	<ul style="list-style-type: none"> <li>• DOS/V devices with the “Designed for Windows” logo</li> <li>• Devices fitted with CPU and RAM that meet the clock and memory requirements for each OS, as specified by Microsoft</li> <li>• Hard disk: At least 100MB of available space</li> <li>• Screen size: 800 × 600 or larger</li> <li>• When using wired LAN connections with the product’s LAN port, operation has been confirmed with LAN cables (Cat5e or higher is recommended) with a maximum length of 20m. Using cables above this length may cause communication to become unstable.</li> </ul>
Required connectors	USB connector, LAN connector
Supported OS	Windows11
Note regarding OS support	<p>*Operation with supported OS is only guaranteed on pre-installed machines and clean install machines. (MAX cannot guarantee operation with computers that have been upgraded.)</p> <ul style="list-style-type: none"> <li>• “Pre-installed machines” refers to computers shipped from the factory with Windows installed by the computer manufacturer.</li> <li>• “Clean install machines” refers to computers that satisfy the Windows operating environment requirements and have been initialized before installing Windows. For such devices, only computers on which correct OS operation has been confirmed are covered.</li> <li>• Refer to the MAX website for the latest OS information.</li> </ul>

## Compliance information

---



### Manufacturer

MAX CO., LTD., 103-8502: 6-6, Nihonbashi Hakozaiki-cho, Chuo-ku, Tokyo

### EU authorised representative & importer

MAX EUROPE B.V

Antennestraat 45, 1322AH, Almere, The Netherlands

### UK economic operator

Lighthouse (UK) Ltd

Unit 23, Charnwood Business Park, North Road, Loughborough, Leicestershire, LE11 1LE United Kingdom

## DECLARATION OF CONFORMITY

---

MAX declares that the model of the wireless device(LM-3000PRO EU) complies with Directive 2014/53/EU. The full text of the EU Declaration of Conformity can be obtained at the following internet address.

*URL : <https://www.max-europe.com/>*

(a) Operating frequency band(s)

2412~2472MHz 1~13ch

(b) Maximum radio-frequency power

20dBm(100mW)

## Waste Electrical and Electronic Equipment Directive

---



1. This product cannot be disposed of as general waste because it may contain hazardous substances. When the product is no longer used, please hand it over to an appropriate collection/recycling facility.
2. After use, please dispose of the product through proper collection channels. This will promote reuse and recycling and reduce environmental impact.

# 12-5 MAIN UNIT AND LETATWIN PC EDITOR PRO VERSION INFORMATION

## 12-5-1 MAIN UNIT VERSION INFORMATION

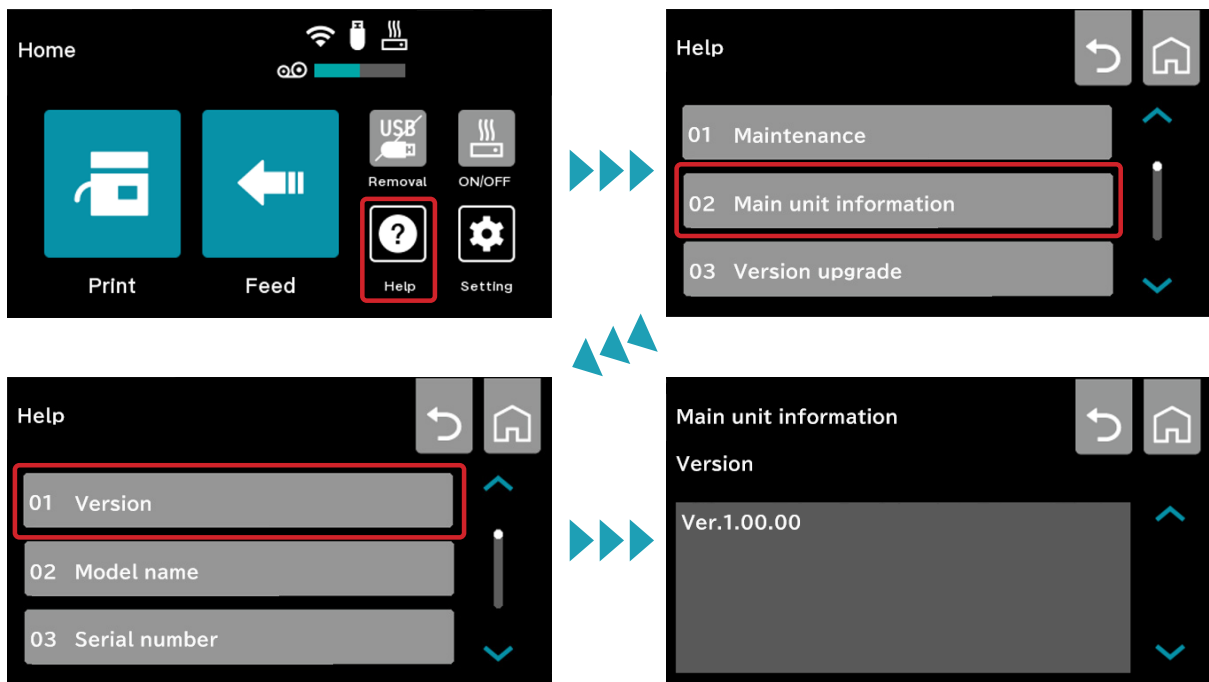

## 12-5-2 LETATWIN PC EDITOR PRO VERSION INFORMATION

To check version information, access “Help”- “Version information” in LETATWIN PC EDITOR PRO.

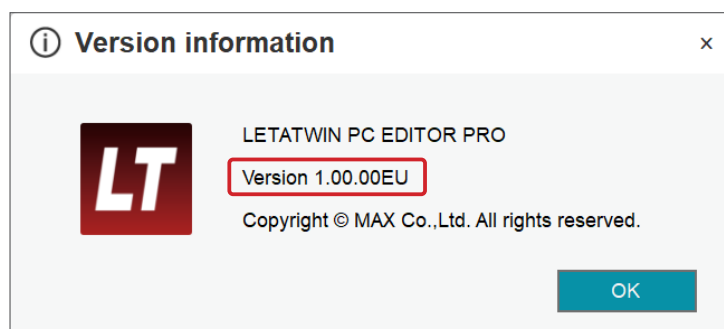
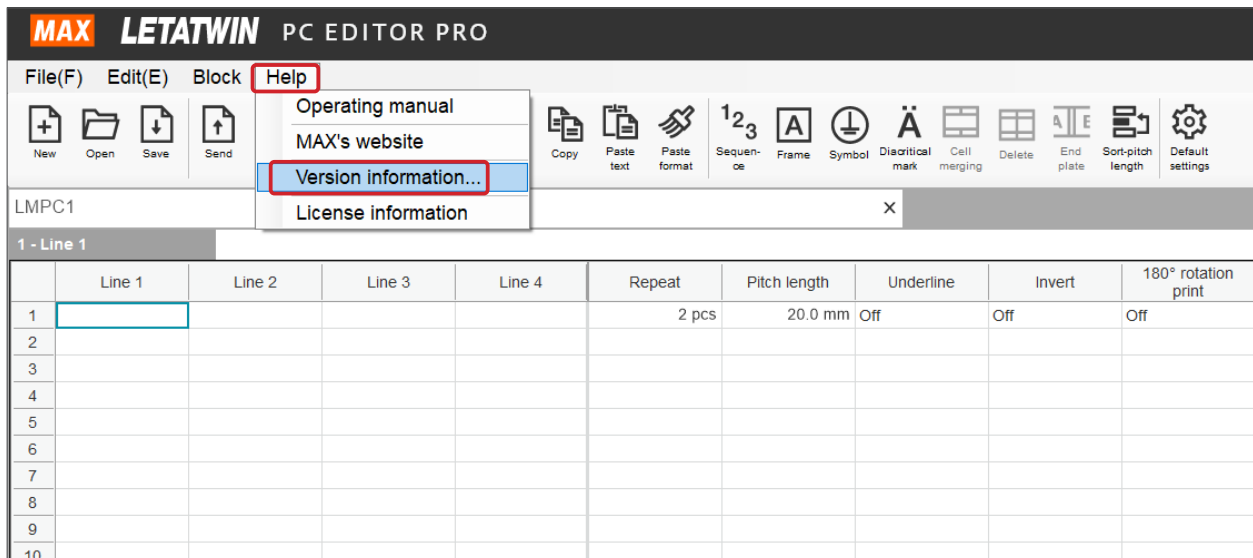

## 12-5-3 HOW TO UPDATE THE MAIN UNIT

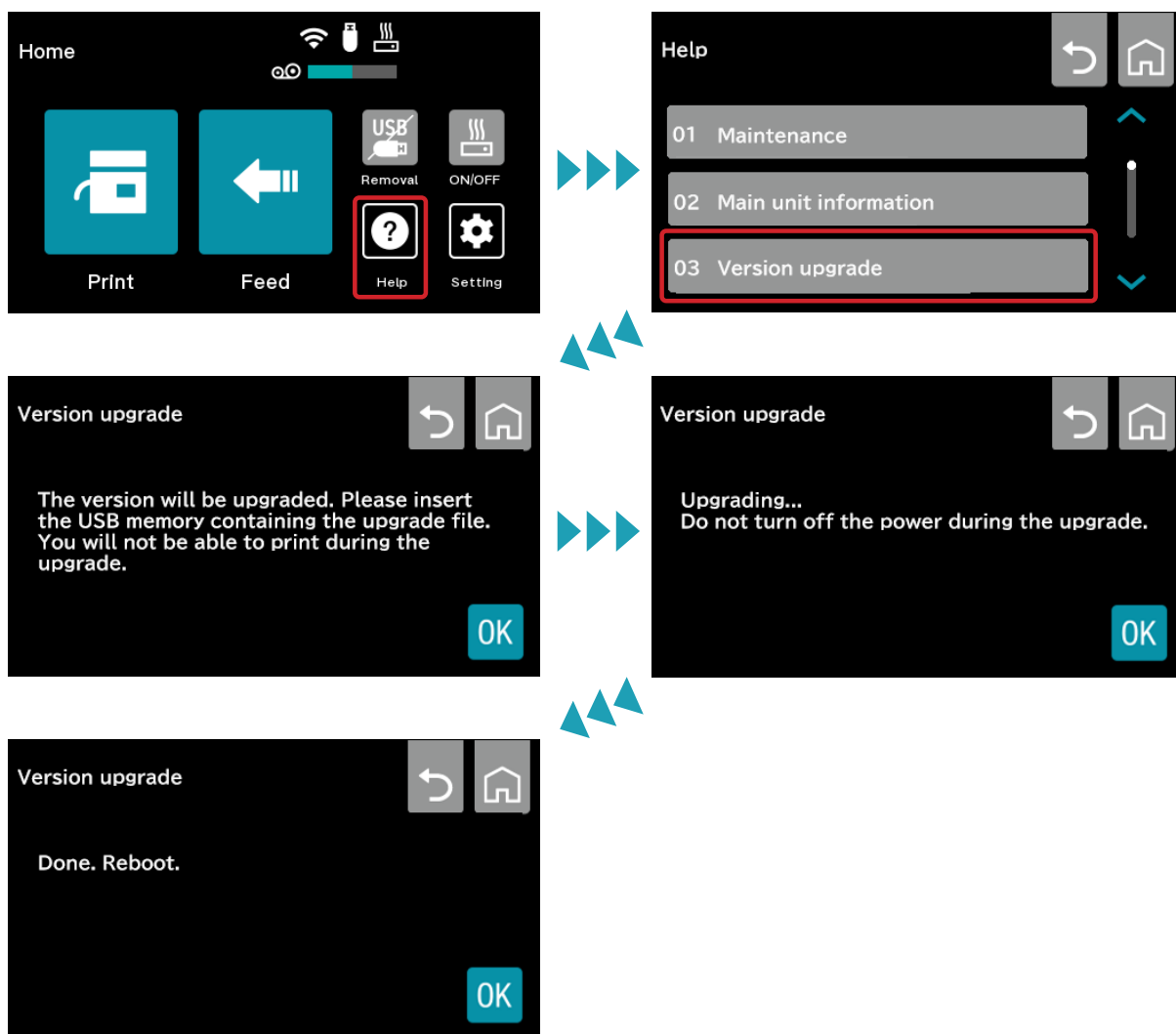

How update files are distributed

- Firmware updates may be provided for this product to improve security and functionality.
- If an update is deemed necessary, we will send a Firmware update notification to the registered email address.
- Update files can be downloaded from our website.
- Updating will allow you to use this product more safely.
- Update information is only available to users who have registered in advance.

(Security updates are available for 5 years from the date of purchase)

<Support Information for European Customers>

The support period for this product is 10 years from the product release date.

You can check the end date of the support period at the following URL on our website.

Support Information Page for European Union (EU) Member Countries:

<https://www.max-europe.com/product-security/>

Please note that if the end of sales date changes, the end date of the support period may also be revised.

# 12-6 CONTACT INFORMATION

## **MAX CO.,LTD.**

6-6 Nihonbashi Hakozaki-Cho,Chuo-Ku,Tokyo,Japan

TEL: (81) 3-3669-8131

<https://www.max-ltd.co.jp/global>

## **MAX EUROPE B.V.**

Antennestraat 45, 1322AH, Almere, The Netherlands

TEL: (31) 36-546-9669

<https://www.max-europe.com/>

Please report vulnerabilities in this product to the following:

## **MAX EUROPE B.V.**

Antennestraat 45, 1322AH, Alme

TEL: (31) 36-546-9669

<https://www.max-europe.com/>

**MAX**